



Article

Creative Accounting Determination and Financial Reporting Quality: The Integration of Transparency and Disclosure

Ibtihal A. Abed ¹, Nazimah Hussin ¹, Hossam Haddad ², Tareq Hammad Almubaydeen ³ and Mostafa A. Ali ^{1,*}

¹ Azman Hashim International Business School, Universiti Teknologi Malaysia, Kuala Lumpur 54100, Malaysia; ahmed-1988@graduate.utm.my (I.A.A.); nazimah.kl@utm.my (N.H.)

² Business Faculty, Middle East University, Amman 11831, Jordan; Hhaddad@meu.edu.jo

³ Faculty of Economics and Administrative Sciences, Zarqa University, Zarqa 11831, Jordan; tmbydeen@zu.edu.jo

* Correspondence: mostafa1988@graduate.utm.my

Abstract: The phenomenon of creative accounting has attracted the attention of researchers for decades, especially in the financial sector for its implications on the quality of financial reporting. Although several procedures have been developed by researchers and practitioners to determine any manipulation in financial reporting, the practice of creative accounting is still prevalent, resulting in poor quality financial reporting. The present study investigated the moderating role of transparency and disclosure with respect to enhancing the impact of creative accounting determinants and financial reporting quality in the context of commercial banking. A deductive research method driven by a survey questionnaire is used to examine the proposed hypotheses and attain the designed objectives. The analysed data provide a theoretical conceptualisation and practical validation for the integration of the moderator in the relationship between creative accounting determinants and financial reporting quality in banks, with significant advantages. Furthermore, the present research findings show that the degree of impact for creative accounting determinants is linked to the aspects of transparency and disclosure. Lastly, the results present concurrent evidence of the flexibility of creative accounting determinants with implications for transparency and disclosure and financial reporting quality.

Keywords: ethical issues; disclosure quality; internal control; ownership structure; qualitative characteristics; manipulation; information asymmetry; commercial banks



Citation: Abed, I.A.; Hussin, N.; Haddad, H.; Almubaydeen, T.H.; Ali, M.A. Creative Accounting Determination and Financial Reporting Quality: The Integration of Transparency and Disclosure. *J. Open Innov. Technol. Mark. Complex.* **2022**, *8*, 38. <https://doi.org/10.3390/joitmc8010038>

Received: 12 December 2021

Accepted: 27 January 2022

Published: 10 February 2022

Publisher's Note: MDPI stays neutral with regard to jurisdictional claims in published maps and institutional affiliations.



Copyright: © 2022 by the authors. Licensee MDPI, Basel, Switzerland. This article is an open access article distributed under the terms and conditions of the Creative Commons Attribution (CC BY) license (<https://creativecommons.org/licenses/by/4.0/>).

1. Introduction

Creative accounting is the practice of influencing financial indicators using accounting knowledge without explicitly violating accounting policies, rules, and the law. Creative accounting is practiced to show the financial position as the company management would like it to be; stakeholders are informed of what the management wants them to perceive [1]. This practice allows financial information to be manipulated from its proper and accurate form; the creative accountant exploits the existing rules or, in several cases, ignores one or more rules [2]. Researchers at one time proposed that all companies in the country were manipulating for profit advantages [3]; the published information is based on accounting books that are mildly or severely manipulated. The authors assert that the figures disclosed biannually to investors are manipulated to guard against the guilty. The researchers indicate that “It is the biggest con trick since the Trojan horse. In fact, this deception is all in perfectly good taste. It is totally legitimate. It is creative accounting” [3].

On the other hand, financial reporting provides reliable and accurate data in a timely fashion, this being needed by stakeholders for the making of decisions related to the efficient operations of the bank [4]. The primary purpose of financial reports is to present the financial data to their users for better awareness and continuous updates on the financial status of the bank. However, the current secretarial policy provides some choices regarding accounting practices and the objective judgments required to define the measurement

strategies, recognition criteria, and, in some cases, the characterisation of the accounting bodies. Investigations in the previous literature contribute toward identifying the present research problem. This work has provided information about the shortcomings in financial reporting in the banking sector, whereas numerous studies reported that creative accounting contributes to indicating the levels of financial reporting [5].

Prevailing accounting practices permit a certain degree of freedom concerning the use of accounting policies [6]. Professional judgment is used to delineate recognition rules, measurement techniques, and the characterisation of the accounting body. While exercising such choices, executives might deliberately conceal material information or misrepresent accounting figures in order to project an attractive financial position. Profits may be reported as higher than they are to increase attractiveness or lower to reduce tax liability. It has been asserted that accountants use domain knowledge to manipulate financial information and reporting for businesses, which is referred to as creative accounting [7]. Previous research indicates that creative accounting has four fundamental determinants: ethical issues, disclosure quality, internal control, and ownership structure [8]. Therefore, this study will evaluate creative accounting by determining the degree of entrenchment of creative accounting specific to Iraqi banks' financial reporting. Commercial banks are vital for a nation's financial structure because these banks facilitate nationwide domestic deposits and facilitate fund availability for investment through securities or lending routes [9].

Creative accounting has a significant positive correlation with transparency and disclosure. Transparency and disclosure are set as the framework used to direct and regulate business organisations [10]. Transparency and disclosure delineate stakeholder responsibilities and rights, laying the foundation for several stakeholders' rights, including the board members and managers; furthermore, they define the rules and regulations for corporate decision making [11]. The transparency and disclosure framework is used to direct and regulate businesses. In contrast, creative accounting concerns manipulating financial indicators from their proper and accurate form to another form that provides an undue advantage to some stakeholders; creative accounting exploits or violates rules for undue advantage [12].

Executives oversee company auditing, accounting, and financial reporting; therefore, they are effective at preventing creative accounting. Moreover, discussions indicate that inadequate governance is correlated with unreasonably high compensation for executives who are motivated to indulge in manipulative behaviour [13]. Numerous stakeholders are adversely affected because of creative accounting [14]. Stakeholders could be customers, creditors, suppliers, equity investors, regulators, among others. There is a general scarcity of creative accounting-specific research in Iraq and the Middle East because this area has not received due attention. Along the same lines, there is relatively little provision for formulating systems to help monitor and check creative accounting in Iraqi banks. Nevertheless, there is research concerning creative accounting practice in developing nations. In this regard, the authors of [15] studied several developing countries and formed three groups for comparing creative accounting and the protection of investors. The researchers concluded that the last group had little investor protection, but creative accounting incidence was high and aggressive. However, the present study aims to examine the joint influence of determinants of creative accounting and transparency and disclosure on financial reporting quality in the commercial banking sector of Iraq. It concentrates on two questions:

1. What are the effects of creative accounting determinants on financial reporting quality in the banking sector?
2. To what extent do transparency and disclosure moderate the relationship between creative accounting determinants and financial reporting quality?

2. Theoretical Background

2.1. Creative Accounting Determinants and Financial Reporting Quality

Creative accounting practices do not often break the law, nor they are considered illegal; however, creative accounting managers exploit ambiguities in the law for portraying the financial standing of the firm according to the preferences specified by the management [16]. These practices help them overestimate the economic and financial condition of the firm, which leads to poor accounting and financial reporting. The organisations present their annual financial results to the public, which describes all data related to their financial position, cash flow, and company performance. Earlier studies have stated that this data is very useful to many users (i.e., private and public) for making some economic decisions [17]. For instance, financial statements can affect the election of the bank owner [18]. Earlier studies showed that creative accounting practices affected financial reporting quality [15,19–21]. It is generally seen that the top management pressurizes the accounting personnel in their firms to overestimate the financial state of their companies [22]. As a result, the accounting managers often manipulate the financial and accounting information for maximising the earnings of the firms. These dishonest and manipulative practices benefit the shareholders, since an increase is noted in the share prices of these listed firms. However, creative accounting practices can often lead to self-destruction, as a false disclosure of the financial reports regarding the company's debt can mislead the public [23].

In this study, the researchers have attempted to define some determinants which can affect financial reporting quality. This study can also explain the various manipulative practices which are implemented during the presentation of financial reports and their effect on the banking industry. The different accounting engineering techniques, which are implemented by the firm, can help them present a desirable public image and portray a financial performance based on their specified preferences. This is done by exploiting legislative ambiguities. All these practices decrease financial data reporting quality. Hence, the firms that implement a higher level of creative accounting practices tend to exhibit low or poor quality financial reporting [24,25]. The accounting managers of these firms, who carry out creative accounting practices, project a higher financial performance and better earnings, stock, and share prices [7].

The ethical choices implemented in an organisation are important for the rejection or adoption of creative accounting practices. The falsified financial records cannot be recognised by the different investors, hence misleading them cannot be justified [26]. According to [27], the ethical environment describes how and why the firm management uses creative accounting practices as an effective tool. People lose faith in these companies, which can also affect the financial condition of the firm. Deliberately tampering with financial statements in order to deceive investors is not ethical [28]. The tendency of some managers to focus on short-term gains is mainly responsible for unethical environments in firms, which further encourages poor financial reporting [29]. Investigations identified that when managers adopt ethical behaviour, the accounting transparency in the firm can increase [30]. A direct approach suggested that managerial and corporate ethics affects the quality of financial reporting [31]. Thus, it can be concluded that an ethical environment and ethical management can affect the quality of financial reporting.

A direct correlation is noted between the degree of creative accounting practices and information asymmetry, wherein an increase in creative accounting practices indicates an increase in information asymmetry. Hence, information asymmetry between investors and management is vital for creative accounting practices [32]. Improved disclosure quality in an organisation leads to a decrease in information asymmetry. Thus, a decrease in the information asymmetry of the management is related to low earnings. This highlights a direct relationship between disclosure quality, creative accounting, and firm value [33]. Thus, after reviewing many papers, the researchers noted a positive relationship between disclosure quality and financial reporting quality. Various researchers who investigated the accounting practices stated that the information asymmetry can be decreased by obtaining a high disclosure quality [34]. Thus, disclosure quality was regarded as a major concept which

helped in significantly decreasing profit and information asymmetry conflicts, thereby leading to an increase in the value of firms [35]. The previous studies highlighted a positive relationship between financial reporting quality and the amount of information that is disclosed by the management. This type of positive relationship hindered the managerial earning manipulation and unethical opportunistic financial reporting behaviour carried out by the firm's management [36].

A well-defined and established internal control can decrease auditing fees and improve the integrity and reliability of the financial reporting presented by an organisation [20,37]. Results showed that a weak or complete lack of internal control decreases the objectivity and quality of the financial reporting presented by the management in a firm. There is a positive correlation between financial reporting quality and strong internal control [38]. Furthermore, the authors of [14] stated that the adoption of internal control is vital for improving the quality of financial reporting. It had been reported that a primary correlation obtained between the need for effective internal control and financial reporting quality [39]. They explained the statements made by the former Chairman of the US Securities and Exchange Commission (SEC), who stated that the quality of financial reporting was determined by internal control. Thus, it could be concluded that an inefficient internal control causes a misstatement in the quality of financial reporting.

Any failure to detect or prevent frauds or wrong statements in financial reporting can negatively affect a company's quality. Furthermore, an inefficient internal control on the financial reporting presented by the company can affect its financial reporting quality. However, an efficient internal control of financial reporting reflects the commitment of the organisation to disclose all vital information to the public and their shareholders [40,41]. Thus, it is noted that internal control of financial reporting can improve the quality of financial reporting. Several researchers have mentioned that an internal control on financial reporting can affect any improvements that are carried out in financial reporting quality [42–44]. A higher ownership structure can improve the external control on the management, thereby improving the quality of the financial reporting [45]. The ownership structure decreases the extent of creative accounting practices; however, this effect is dependent on the size of the firm [46]. According to [47,48], the ownership structure affects the quality of financial reporting in firms which use creative accounting indicators. Many earlier researchers have observed that the ownership structure of firms showed low efficiency in monitoring their agents [49].

Other researchers also observed a positive effect of the ownership structure on firm performance [50]. Additionally, the ownership structure positively affected financial reporting quality [51]. The correlation between financial reporting quality and ownership structure has been studied in many types of research. Shareholders have a lesser incentive to manipulate financial statements, thereby curtailing creative accounting practices. Similar observations were reported by a few earlier studies [15,45,52], which concluded that a negative correlation existed between creative accounting and ownership structure. They also noted that ownership structure improved financial reporting quality by decreasing the level of creative accounting practices. However, not all earlier studies followed this theory. Where the ownership structure of an organisation carried out weak supervision of its employees, this could decrease financial reporting quality [52]. Others detected a significant effect of ownership structure on creative accounting and financial reporting quality [53]. As a result, owners and agents do not face any conflict of interest [48]. Based on these results, the following hypotheses can be formulated:

Hypothesis 1a (H1a). *Giving little consideration to ethical issues results in a low level of financial reporting quality.*

Hypothesis 1b (H1b). *A low level of disclosure quality indicates a low level of financial reporting quality.*

Hypothesis 1c (H1c). *A low level of internal control indicates a low level of financial reporting quality.*

Hypothesis 1d (H1d). *A low level of ownership structure indicates a low level of financial reporting quality.*

2.2. The Integration of Transparency and Disclosure

As transparency and disclosure of vital information are regarded as significant elements of transparency and disclosure, the managers of firms are less likely to engage in shady creative accounting practices which do not offer any personal benefits [54]. When managers are transparent in their dealings, there is a decrease in creative accounting practices [13]. Furthermore, even the directors of organisations do not facilitate the implementation of creative accounting practices if there are no personal benefits in doing so. They also are scared of punishment if the shady creative accounting practices can be detected easily. Hence, transparency and disclosure are related to the disclosure of information regarding standardised documents, like financial reports associated with the business practices carried out in the organisation [55].

However, with regards to transparency, organisations need to provide appropriate and timely disclosure of all relevant information to customers [56]. Transparency is regarded as an important factor that makes an organisation more attractive to investors. The level of transparency is dependent on the ability and willingness of the management to provide distinctive information to the market participants [57]. While it has been argued that transparency is an ethical quality, it has been considered a pro-ethical quality that enabled or impaired other ethical practices [58]. This term defines what type of information is disclosed and what information can be used by an organisation for implementing the ethical practices to which the organisation is committed. Some researchers have argued that the explicit ethical designs that describe how the ethical principles were embedded in the development of the software designs represent vital information which is disclosed by organisations in support of their ethical status [59].

Though many arguments have been presented in the literature regarding higher transparency, organisations do not readily disclose all their information. However, since the benefits and costs cannot be measured objectively and accurately, a majority of organisations are shifting to complete disclosure [57]. It was noted that if organisations indulge in a lot of strategic interactions with one another, information disclosure makes them lose their competitive advantage, which decreases their profitability [35]. It has been seen that the establishment and maintenance of a complicated financial disclosure system is an expensive process since it involves a combination of numerous financial and non-financial items which cannot be exposed easily. Thus, based on their market structure, various governments have developed rules which have to be followed by the organisations in their country when it comes to accounting and disclosing information [60].

A significant positive relationship between corporate transparency and disclosure and ownership structure has been noted [15]. Organisations' ownership structures in a majority of countries are concentrated [50]. Hence, a conflict of interest was noted between the large and minor shareholders, which constitutes a major transparency and disclosure issue [61]. The agency theory stated that the potential conflict of interest between shareholders and company management was prominent in countries having a dispersed ownership structure. Ownership dispersion increased the demands for information and disclosure of firms by external parties [62]. Hence, organisations with a dispersed ownership structure offer more information to their shareholders compared to organisations with a concentrated ownership structure [46]. Based on the above logic, we propose the following interaction hypotheses:

Hypothesis 2a (H2a). *Transparency and disclosure positively moderate the relationship between ethical issues and financial reporting quality.*

Hypothesis 2b (H2b). *Transparency and disclosure positively moderate the relationship between disclosure quality and financial reporting quality.*

Hypothesis 2c (H2c). *Transparency and disclosure positively moderate the relationship between internal control and financial reporting quality.*

Hypothesis 2d (H2d). *Transparency and disclosure positively moderate the relationship between ownership structure and financial reporting quality.*

The theoretical framework of the current study contains one independent variable, ‘creative accounting’, one moderating variable, ‘transparency and disclosure’, and one dependent variable, ‘financial reporting quality’, as shown in Figure 1.

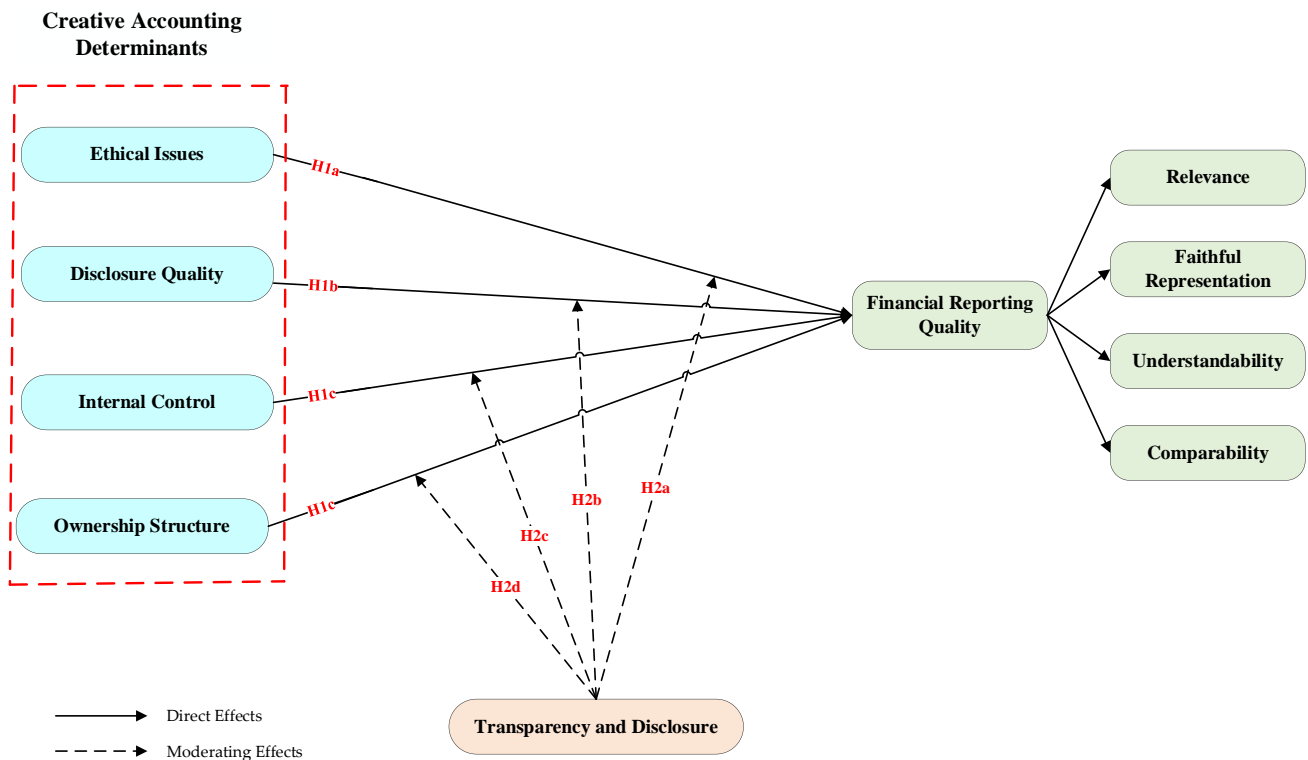

Figure 1. Conceptual framework of the present study.

3. Research Method

3.1. Study Population

The present research population encompassed 24 Iraqi commercial banks in the year 2020. The banks are situated in numerous governorates with different branches and are regarded as the largest and major monetary exchange markets in Iraq. Baghdad, being the capital of the country, holds the largest number of banks in the country. The ever-growing demand for research has given rise to the necessity for an effective technique for defining the required sample size in a given population. The previous methodological literature declared that no additional calculations are required to identify the sample size in quantitative researches [63]. Researchers developed a standard table for calculating the size of samples required for studies. The current study aimed to investigate a population of 7000 employees from 24 commercial banks. In addition, it has been stated in [64] that in quantitative research no extra estimations are needed for identifying the size of a sample wherein a standard table can be developed to calculate the sizes of the samples. Thus, a sample size of 364 participants was required to investigate the current phenomena. As such, a total of 500 questionnaires were distributed to employees in banks. This took into

consideration that the larger the study sample, the more the results can be generalized to the target population. The selected sampling method enables the gathering of accurate information from the population concerning creative accounting, financial reporting quality, and the moderator.

3.2. Sampling Technique

Purposive sampling of the estimated population was considered to be more suitable for the present research. Bank accountants who are experienced and familiar with the preparation of financial reports are expected to possess and reflect expert knowledge and they are able to give relevant data to research inquires. Thus, the respondents for the present research were bank accountants involved in the banking business, regardless of their rank or job position. Hence the choice of the individual-level analysis for the present study to evaluate the correlation between creative accounting, financial reporting quality, and transparency and disclosure. Furthermore, the respondents used for the study comprise accountants serving in commercial banks. The selection of accountants is a planned decision: accountants communicate the most with commercial banks. Therefore, they possess a strong understanding of the support required by firms for 'value creation'. These reasons have established the researcher's position to measure variables and forecast the correlation between the specified variables precisely.

3.3. Data Collection Procedures

The study questionnaire was prepared, considering the primary objective and customised for specific fundamental aspects. The questionnaire permits rapid data collection [65] and immediate questioning for respondents' doubts [66]. Data collection began on 10 September 2020 and was concluded on 10 December 2020, which is roughly three months. Bank branches are scattered across different areas in Iraq; hence, a substantial amount of time was allocated for data collection. The banks were informed before the research team's arrival for questionnaire distribution. The data collection process was indicated in advance. Some banks also required permission from the authorities through in-person or email-based approval before they could disclose data. This process consists of bank managers seeking permission to communicate with respondents individually. After permission was obtained, respondents were informed about the research and were provided ample time to answer all questions. In case respondents faced challenges, they would be assisted so that they understood the context precisely. It was required that respondents answer the survey and hand over the responses directly to enhance the response rate. Data collection ended with the researchers having 392 responses.

3.4. Response Rate

To achieve the appropriate response rate, 500 questionnaires were distributed to employees in selected commercial banks in Iraq. Out of the 392 questionnaires that were returned to the researchers, 28 questionnaires were excluded as they had incomplete responses or missing data. This is a safe and easy method that is most commonly used in any statistical study to avoid bias due to incomplete questionnaires and cases of missing data. Thus, 364 responses were used for the analysis. The distribution of the questionnaires and the response rate are shown in Table 1.

Table 1. The response rate of the data collected.

Description	No. of Questionnaires	Percentage
Total questionnaires distributed	500	100%
Completed questionnaires received	392	78.4%
Questionnaires uncompleted /with missing data	28	7.1%
Usable questionnaires	364	92.9%

3.5. Measures

Creative accounting: measurement of the determinants of CA were developed based on various studies, such as five items to measure ethical issues that has been adapted from [67]. Another five items have been adapted from [68] to measure disclosure quality. For internal control, five items were adapted from [69]. Ownership structure analysis has adapted five items from [70]. Transparency and disclosure: the five items that measured T&D are mainly based on five items adapted from [71]. Financial reporting quality: this study measured FRQ using 20 items based on the research of [72]. (See Appendix A) Responses were made on a five-point scale ranging from 1, strongly disagree, to 5, strongly agree.

3.6. Analysis and Results

There were two main stages to the data analysis. The first stage was conducted using SPSS.v²⁵ to provide information about the data distribution, response rate, multicollinearity, and coding. This was followed by the screening of the data to ensure there were no missing data or outliers. The second stage of the data analysis in the current study was conducted in two phases using AMOS.v²⁴. The first phase was a confirmatory factor analysis (CFA) to assess the overall measurement model, while the second phase involved structural equation modelling (SEM), which included testing the hypothesis of the study.

3.6.1. Normality

Multivariate normality was checked, which is more relevant in the context of multivariate analysis. To test for normality regression, standardised residual histogram and normal probability plots were employed, along with the skewness and kurtosis statistics in order to check the normality of distribution. The asymmetric, bell-shaped curve on the standardised residual histogram, according to [73], and the distribution of the data can be seen in the histograms, which is considered one of the best statistical methods that measure the normal distribution of the data. The values range from about -2.2 to 2.2 . Figure 2a displays the regression standardised residual histogram.

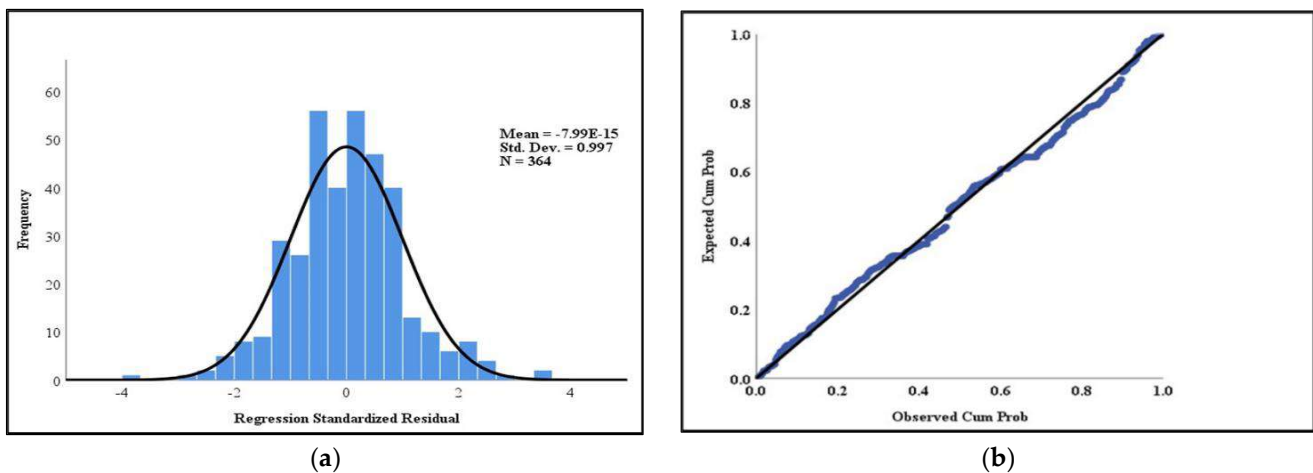

Figure 2. (a) Regression standardised residual of independent and dependent variables. (b) Normal P–P plot of regression standardised residual.

According to [73], the distribution of the data can be seen in the P–P plot, which is considered one of the other statistical methods for measuring the normal distribution of the data. The asymmetric, bell-shaped curve and a straight line on the normal P–P plot show not a major deviation from normality. From the normal P–P plot it can be seen that the dots are closely aligned to the straight line but some of the dots are almost touching the straight line. The points fall right on the line when normality has been met. For the most part, the normal P–P plot is better at finding deviations from normality in the center of the distribution. In the P–P plot it can be seen that all points are located on a straight diagonal

line with an acceptable ratio. This indicates that there is no significant deviation from the normal position of the data, and thus the data is suitable for conducting the next steps of the analyses. Figure 2b displays data in normal probability plot distribution.

3.6.2. Assessment of Measurement Model

The measurement model shows how latent variables have been measured through their observed variables and assesses their measurement properties. In addition, before proceeding to the structural equation modelling (SEM), the measurement model properties need to be satisfied. Furthermore, in the present study, six reflective variables were used, namely, ethical issues, disclosure quality, internal control, ownership structure, transparency and disclosure, and financial reporting quality. The CFA for all reflective variables was performed in AMOS.v²⁴. Furthermore, the factor loading estimates for all the items were between 0.81 and 0.99 and were above the minimum cutoff point, except the factor loading for item TD5 from the transparency and disclosure variable, which was 0.38, also less than the minimum cut of the point. Therefore, the model fit indices revealed that there was adequate fittingness between the model and the data, whereas the outcomes showed that the CMIN statistic was 2584.080, DF = 884, and CMIN = (CMIN/DF = 2584.080/884 = 2.923). The *p*-value was associated with this result; *p* < 0.000, CFI = 0.921, TLI = 0.916, RMSEA = 0.073. These indices achieved an acceptable fit. The model shown in Figure 3 displays the assessment of the measurement model.

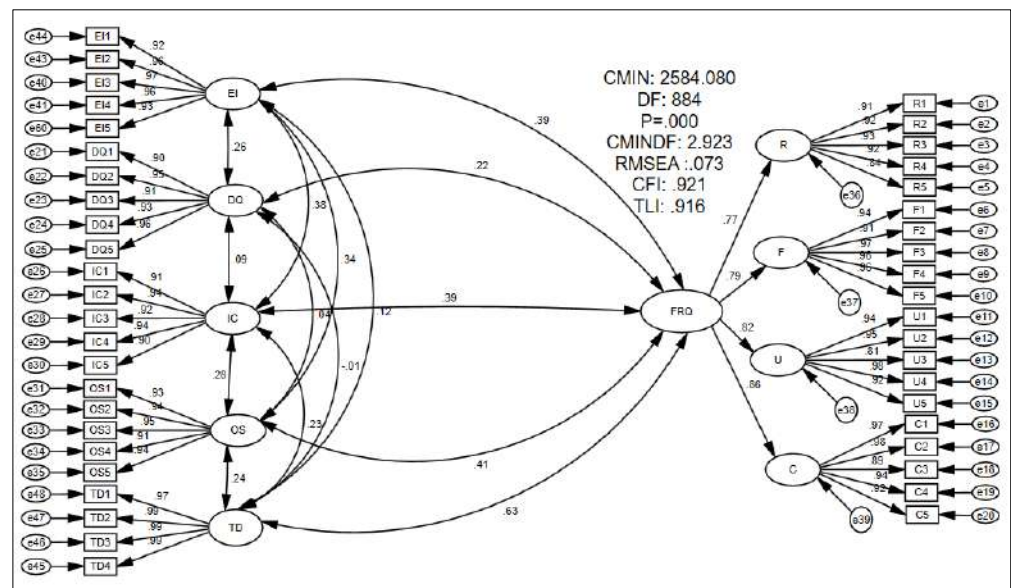

Figure 3. Assessment of measurement model.

Convergent validity is a type of variable validity. It is the extent to which scale items are presumed to represent a variable based on a range of facts about the same variables. The result of Cronbach’s alpha (α) for all the variables was between 0.84 and 0.97. These values were greater than the value of 0.70. Furthermore, the result of Composite Reliability (CR) for all the variables was between 0.88 and 0.99. In addition, the result of the average variance extracted (AVE) for all the variables was between 0.65 and 0.97. These values were greater than the value of 0.50. Furthermore, the result of maximum shared variance (MSV) for all the variables was between 0.07 and 0.39, whereas these values were less than the value of AVE. Furthermore, the result of maximal reliability (MaxR-H) for all the variables was between 0.83 and 0.99. Therefore, based on these results, the present research acquired the recommended levels of convergent validity. Additionally, the results presented acceptable indicators of reliability and convergent validity, as shown in Table 2.

Table 2. Convergent validity for the overall measurement model.

Variables	A	CR	AVE	MSV	MaxR (H)
EI	0.978	0.978	0.901	0.150	0.981
DQ	0.970	0.970	0.866	0.070	0.973
IC	0.965	0.967	0.853	0.155	0.968
OS	0.970	0.972	0.872	0.167	0.972
TD	0.845	0.992	0.970	0.392	0.993
FRQ	0.960	0.883	0.654	0.392	0.887

3.6.3. Assessment of Structural Equation Modeling

Structural equation modeling (SEM) is very useful in examining the inter-dependent relationships among latent variables [74]. It is designed to assess how well a proposed conceptual model can fit the data collected and also to ascertain the structural relationships between the sets of latent variables [75]. The direction of the relationship between the variables showed there was a direct relationship between independent variables and dependent variables. In this study, the measurement and structural models were generated and estimated using SPSS.v²⁵ and AMOS.v²⁴. The goodness-of-fit of the structural equation model indicated an acceptable fit; specifically, the CMIN statistic was 1544.939, DF = 726, CMIN = (CMIN/DF = 1544.939/726 = 2.128). The *p*-value associated with this result was *p* < 0.000, CFI = 0.959, TLI = 0.956, RMSEA = 0.056. These indices were an acceptable fit. Figure 4 shows the SEM that included all the study variables.

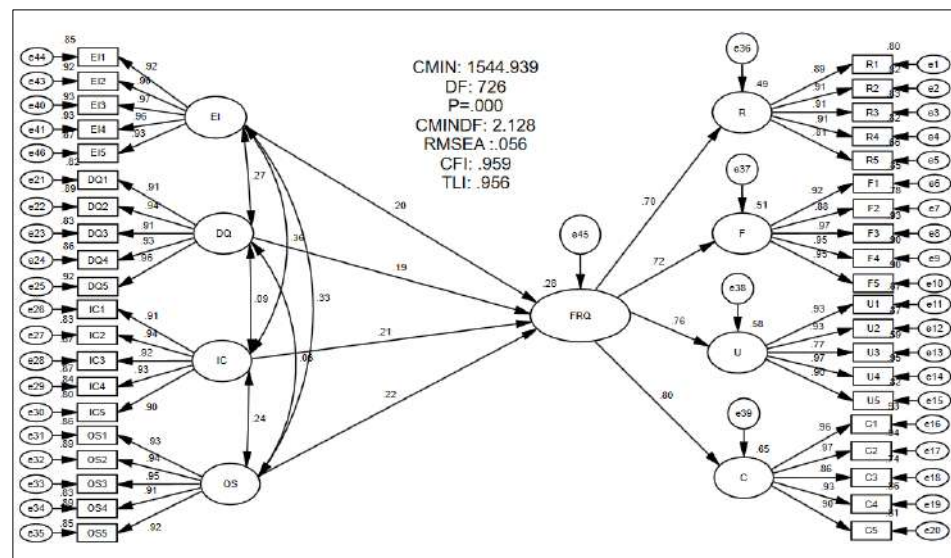

Figure 4. Assessment of structural equation modelling.

This section shows the direct relationships between the determinants of creative accounting and financial reporting quality. The results of H1a have a positive and significant relationship between ethical issues and financial reporting quality ($\beta = 0.200$; $t = 3.328$; $p < 0.000$). Therefore, the relationship between ethical issues and financial reporting quality was supported. The result illustrates that H1b indicates a positive and significant relationship between disclosure quality and financial reporting quality ($\beta = 0.185$; $t = 3.427$; $p < 0.000$). Therefore, the relationship between disclosure quality and financial reporting quality performance was supported. Furthermore, the result indicates that H1c has a positive and significant relationship between internal control and financial reporting quality ($\beta = 0.207$; $t = 3.640$; $p < 0.000$). Therefore, the relationship between internal control and financial reporting quality was supported, whereas the results of H1d have a positive

and significant relationship between ownership structure and financial reporting quality ($\beta = 0.219$; $t = 3.912$; $p < 0.000$). Therefore, the relationship between ownership structure and financial reporting quality was supported, as displayed in Table 3.

Table 3. Relationship between creative accounting and financial reporting quality.

No.	Relationship	Beta	t-Value	p-Value	Decision
H _{1a}	EI→FRQ	0.200	3.328	***	Supported
H _{1b}	DQ→FRQ	0.185	3.427	***	Supported
H _{1c}	IC→FRQ	0.207	3.640	***	Supported
H _{1d}	OS→FRQ	0.219	3.912	***	Supported

Note: *** = $p < 0.000$.

Finally, SEM was applied to detect and estimate the strength of the moderating effect of transparency and disclosure on the relationship between the determinants of creative accounting (ethical issues, disclosure quality, internal control, ownership structure) and financial reporting quality. The goodness-of-fit of the moderating factor transparency and disclosure, indicated an acceptable fit; specifically, the CMIN statistic was 49.979, $DF = 23$, $CMIN = (CMIN/DF = 43.979/23 = 2.173)$. The p -value associated with this result was $p < 0.001$, $CFI = 0.930$, $RMSEA = 0.057$, while the R square was 0.431. These indices were an acceptable fit. Figure 5 shows that transparency and disclosure had an effective impact on the relationship between creative accounting and financial reporting quality within the interactive practice.

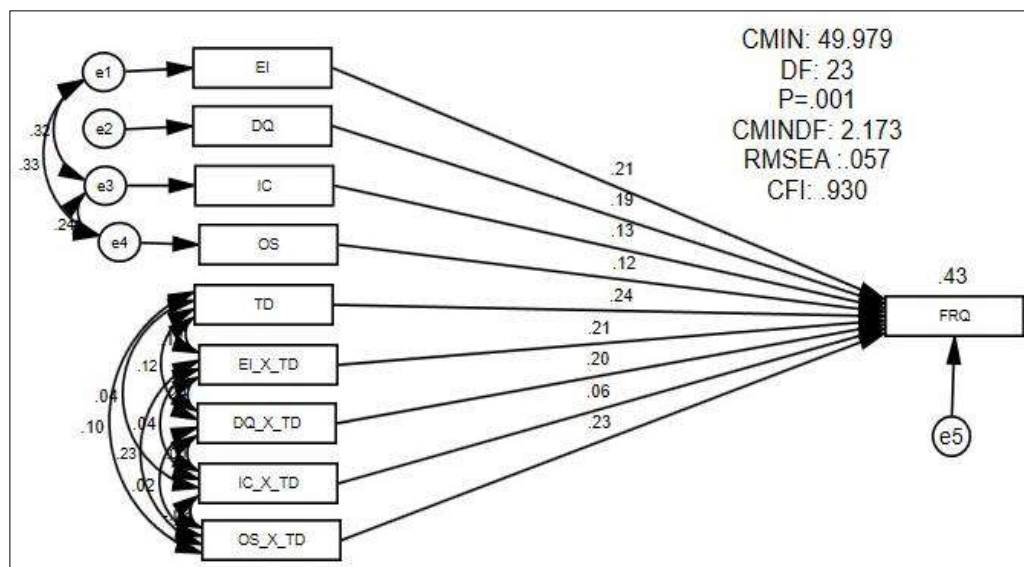

Figure 5. The moderating factor of transparency and disclosure.

In addition, this section shows the indirect moderating effect of transparency and disclosure on the four determinants of creative accounting and financial reporting quality. The result shows, in relation to H2a, that transparency and disclosure have a positive and significant moderating effect on the relationship between ethical issues and financial reporting quality ($\beta = 0.213$; $t = 5.072$; $p < 0.000$). Therefore, the moderating effect of transparency and disclosure on the relationship between ethical issues and financial reporting quality was supported. The result shows, regarding H2b, that transparency and disclosure have a positive and significant moderating effect on the relationship between disclosure quality and financial reporting quality ($\beta = 0.203$; $t = 4.954$; $p < 0.000$). Therefore, the moderating effect of transparency and disclosure on the relationship between disclosure quality and financial reporting quality was supported. The result shows, regarding

H2c, that transparency and disclosure have a negative and insignificant moderating effect on the relationship between internal control and financial reporting quality ($\beta = 0.055$; $t = 1.403$; $p < 0.161$). Therefore, the moderating effect of transparency and disclosure on the relationship between internal control and financial reporting quality was unsupported. The results illustrate, in relation to H2d, that transparency and disclosure have a positive and significant moderating effect on the relationship between ownership structure and financial reporting quality ($\beta = 0.230$; $t = 5.641$ $p < 0.000$). Therefore, the moderating effect of transparency and disclosure on the relationship between ownership structure and financial reporting quality was supported. Table 4 enumerates the results of the moderating effect of transparency and disclosure on the relationship between creative accounting and financial reporting quality.

Table 4. The moderating role of transparency and disclosure on creative accounting and financial reporting quality.

No.	Relationship	Beta	t-Value	p-Value	Decision
H _{2a}	TD_X_EI→FRQ	0.213	5.072	***	Supported
H _{2b}	TD_X_DQ→FRQ	0.203	4.954	***	Supported
H _{2c}	TD_X_IC→FRQ	0.055	1.403	0.161	Unsupported
H _{2d}	TD_X_OS→FRQ	0.230	5.641	***	Supported

Note: *** = $p < 0.000$.

Therefore, transparency and disclosure effectively impacted the relationship between creative accounting and financial reporting quality within the interactive practice. While transparency and disclosure strengthen the positive relationship between ethical issues and financial reporting quality, as shown in Figure 6a, the slope of high ethical issues is a steeper gradient as compared to low ethical issues. This shows that the positive relationship between ethical issues and financial reporting quality is stronger when transparency and disclosure are high in comparison to lower transparency and disclosure. Moreover, transparency and disclosure strengthen the positive relationship between disclosure quality and financial reporting quality. As shown in Figure 6b, the slope of high disclosure quality is a steeper gradient as compared to low disclosure quality. This shows that the positive relationship between disclosure quality and financial reporting quality is stronger when the transparency and disclosure are high in comparison to lower transparency and disclosure.

Additionally, transparency and disclosure strengthen the positive relationship between internal control and financial reporting quality. As revealed in Figure 6c, the slope of high internal control is a steeper gradient as compared to low internal control. This shows that the positive relationship between internal control and financial reporting quality is stronger when transparency and disclosure are low in comparison to higher transparency and disclosure. Finally, transparency and disclosure have a negative and insignificant effect on the relationship between ownership structure and financial reporting quality. As shown in Figure 6d, the slope of high ownership structure is a steeper gradient as compared to a low ownership structure. This shows that the relationship between ownership structure and financial reporting quality is stronger when transparency and disclosure are high in comparison to lower transparency and disclosure. All above-mentioned indications are shown in Figure 6.

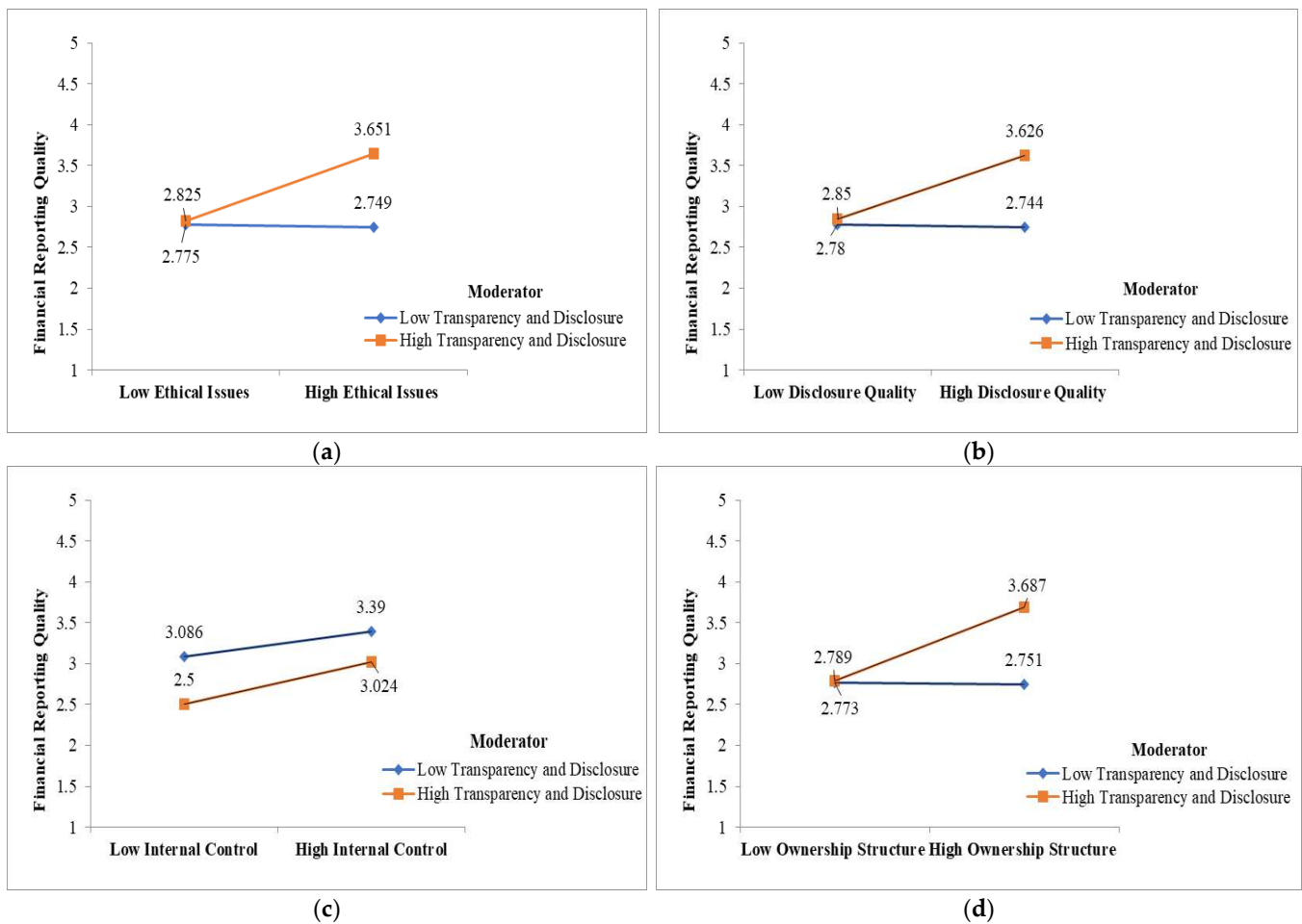

Figure 6. (a) A two-way interaction of the TD on the EI and FRQ. (b) A two-way interaction of the TD on the DQ and FRQ. (c) A two-way interaction of the TD on the IC and FRQ. (d) A two-way interaction of the TD on the OS and FRQ.

4. Discussion

This part of the study discusses the findings related to the present research questions; firstly, the direct relationship between the determinants of creative accounting and financial reporting quality. In this respect, the present research findings explained the positive implications of the determinants in identifying creative accounting practices, as proposed in the hypotheses within the context of Iraqi commercial banks. Accordingly, the result for hypotheses H1a ($t = 3.328$) was aligned with the assumptions provided by the agency theory, whereas the hypothesis indicated significant impacts for maintaining ethical issues on the quality of financial reporting. Furthermore, the results reaffirmed that ethical aspects lead to the establishment of a higher quality of financial reporting practice, as shown in the context of Iraqi commercial banks. In addition, the results acknowledged the findings in the previous studies presented by [29,68,76,77] which demonstrate limited consideration of ethical issues in creative accounting practices in the context of commercial banks.

In addition, the result of H1b ($t = 3.427$) indicated a significant relationship between the constructs with the limited operation of disclosure procedures in the context of commercial banks. This determination designated the higher implications of creative accounting practices on the quality of financial reporting in the banking sector, which was found to be consistent with previous literature reviews [13,24,78]. The implementation of the neo-institutional theory contributed to explain the underlying proposition that limited disclosure practice in the context of commercial banks was due to the pressure exerted by the institutional setup that related to the ownership structure. These results are found

to be in good agreement with numerous studies in the literature, which displays the significance of the linkage between the determinant and accounting practice [13,15,53,79]. However, the present research findings are contradicted by other studies that proposed a limited controlling role of disclosure quality in creative accounting practices [12,33,35]. In brief, disclosure quality is found to be one of the essential determinants of institutional transparency that increases the trust of the public in the financial reporting quality of a bank. This finding is approved in high consistency with previous claims cited in [57] on maintaining ethical concerns through disclosure quality.

The findings of the last two hypotheses related to the first research question. These were H1c ($t = 3.640$) and H1d ($t = 3.912$). As mentioned earlier, the present research findings showed a significant inter-correlation between the determinants of creative accounting, i.e., each of the determinants has an effect on the others. The origin of this relationship is clearly identified in the previous literature and it is verified in the present research findings. Thus, the limited consideration of ethical issues and disclosure quality resulted in the limited implementation of internal control. These procedures enable the practice of creative accounting to take place in the commercial banking sector at various levels according to the ownership structure of the bank. Thus, the present findings are consistent with the previous studies that indicated poor internal control which may lead to higher errors and inaccurate financial disclosure of the financial reporting quality in the banks [60,76].

Therefore, the ownership structure theory explained the findings concerning the last two hypotheses well through identifying the manipulation practice adopted in the banks to avoid poor performance in terms of share value decrease and loss of control in the business. So, the relationship between ownership structure and financial reporting quality can be mentioned, as there are fewer agency problems and information asymmetries in family organisations, in contrast with non-familial ones [4,80,81]. These descriptions verified the previous results in the literature which proposed high impacts of ownership structure in the business on faithful representation in the reports presented by commercial banks [13,77,78]. Yet again the present findings are found to be consistent with [43,79], which asserted that complying with a high level of internal control can reduce the risk of mitigation policies to increase reporting quality through the determinants of creative accounting.

It is worth declaring that the outcomes of this research supported the standing literature concerning the correlation between the determinants of creative accounting to detect fraud, but these determinants fail to control this practice at safe levels [80–83]. These findings are applied to the context of Iraqi commercial banks; although dedicated efforts are constantly made to retain and establish healthy relations with outside shareholders as one of the major resources, additional enhancements were required to reduce fraud within creative accounting to present a high quality of financial reports. This in turn implied that the internal banking system should maintain ethical issues, disclosure to the public, and implement qualified internal control for faithful representation in financial reporting practices in Iraqi commercial banks.

The review of previous literature regarding the present phenomena of interest has justified the significance of implementing the corporate aspect of transparency to organise the financial practice in the commercial banks' context. This finding is consistent with those of [7,12,84], whose authors mentioned that stakeholders can strengthen and enhance financial practice in their institutions through implementing rules and regulations to prevent future financial manipulation through creative practice. Concerning the theoretical role in the moderation process of transparency and disclosure, the implementation of agency theory showed that transparency and disclosure contribute to higher financial reporting quality through justifying asymmetric information which resulted from correcting the perceptions of investors in the capital market. This finding is in agreement with [57,85], whose authors explored the relationship between corporate mechanisms and financial performance.

As a result, the present research hypotheses H2a, H2b, and H2d, driven by the second research question, displayed consistent t-values of 5.072, 4.954, and 5.641. These values reflected flexibility for dominant transparency and disclosure practices that impact creative

accounting and enhance the implications of the determinants. Referring to the nature of creative accounting and transparency and disclosure, transparency and disclosure are banks' stable behaviors that can expose creative accounting to sustain competitive advantages [86], thus further developing financial reporting quality. It is important to mention that the present findings displayed a significant role for transparency and disclosure in moderating the strategic determinant toward faithful, understandable, and comparable presentations in financial reports. Thus, the findings related to H2a validated the previous research in this area, which links ethical issues to the level of disclosure in the financial reports. This finding corroborates the ideas of [87–90], whose authors suggested that ethics in accounting be used to safeguard the profession by obligating accountants to disclose their duties reasonably in the financial statements.

Moreover, neo-institutional theory combines numerous components, such as, law, ethics, and economics, which contribute to explain the necessity for disclosure and the quality of disclosure practices in financial reports. This claim is consistent with the findings for the moderating impacts of transparency and disclosure between disclosure quality and financial reporting at a t-value of 4.954. The theory was also found to be useful for developing and maintaining relationships with stakeholders through disclosing information in financial statements and ensuring a good relationship between managers, stakeholders, and other invested parties. This finding accords with our earlier observations and the studies of [91], which showed that disclosure practice combined with a high level of transparency enabled stakeholders to attain more significant data that allowed them to identify and remedy internal and some external problems. In addition, the study confirms the findings of [92,93]—that transparency in financial information is important to present investors and future development plans. Therefore, information should be disclosed to allay investors' fears, and for this reason, the present theoretical triangulation was found to successfully fit the present study.

In contrast, the results did not support hypothesis H2c due to the absence of any statistically significant value for the moderating relationship among the creative accounting determinants of internal control, transparency and disclosure, and financial reporting practices, which resulted in a t-value of -1.403 . It seems possible that these results are due to the high impacts of the other moderators in maintaining ethical issues, which consequently reduces the impacts of this moderator on the determinant of internal control. However, the present disclosure of the finding indicated the existence of a gap between what audit committees say, what they do, and what is mandated by their charter. Although this gap may be due to several reasons, including liability concerns, it raises the general issue of transparency with respect to activities of the internal control despite the changes made in disclosure requirements. Although, these results differ from some published studies, such as [14,61,94], they are consistent with those of [41,82], which showed a high level of compliance across firms with respect to exchange-mandated disclosures, which are more prevalent in larger firms, depository institutions, and firms with independent internal controls. The present findings contributed to the previous literature review regarding the pressing necessity for a legislative overhaul of the regulatory agencies that enforce the banking sector's laws and regulations, as shown in the studies of [43,95].

In a broader perspective, the implementation of transparency and disclosure as a moderator represents the mechanisms and norms applied to complement and protect the shareholder interests. This claim corroborates the findings of a great deal of the previous work of [35], in which it was indicated that transparency and disclosure philosophy depends on the transparency and disclosure that improves shareholder trust. Regarding financial reporting practice, the more adherence to transparency and disclosure rules, the higher the quality of relevant, faithful, and understandable financial reports. Those claims are shown to have similarities to the attitudes concerning financial practice expressed in the previous works of [96–98]. They indicate that the procedures carried out by judicial accountants affect the nature of the relationship between the application of transparency and disclosure rules in their different dimensions and the quality of financial reporting.

5. Research Implications

The present study acknowledged the previous contributions in [99] concerning the impacts of creative accounting practices on financial reporting quality. The present investigation indicated an obligation to focus on the value of creative accounting determinants in the financial sector, especially for preparing financial reports in the commercial banks of Iraq. The presence of transparency and disclosure contributes to a healthy accounting practice in the banking sector. As a result, this study presented a useful strategy for practitioners, scholars, and policy makers to follow through in examining the essential determinants of creative accounting that can lead to the detection of reasons for fraud financial reporting as well as indications for improving its quality in the commercial banking sector, with significant consequences for national economic policy. In brief, the results and analyses of data in the present study exemplified various practical contributions to the main knowledge domain of the cited topic.

First, this study showed that creative accounting requires more focus on the strategic determinants for controlling financial reporting practice in the commercial banking sector. It showed some important managerial inferences regarding the practice of creative accounting in financial reporting, which indeed represents a causal connection between the two concepts. Certainly, it is sensitive to minor external environment change, knowledge-probing and interpretation capacity, opportunity and threat-discovering ability, and making decisions depending on the demands and efficiencies to reconfigure various resources based on knowledge whenever needed. Second, the conceptual framework of this study provides a broad and varied evidential basis from the viewpoint of academics, businesses, and government organisations for actively participating in the encouragement and development of means of determining fraudulent accounting practices in the preparation of financial reports within organisations. This conceptualization was incorporated with the findings of [100], in which it was stated that financial institutions can acquire specific standards for identifying and developing their strategic resources and capabilities.

Third, the moderator offers some analytical tools for monitoring and evaluating financial reporting quality in the present research context. This can ensure that the board of directors fulfil the fiduciary duty of overseeing the alignment of financial reporting with the best interests of the company and its shareholders. Thus, it is suggested that related support from academics and businesses may be essential for obtaining the required moderation in the banking sector. In addition, cooperation among various structural units, researchers, and professionals within the bank can contribute immensely to the pedagogical significance of this study. Thus, it has concentrated on the strategic planning, careful projection, and anticipation of design infrastructures balanced with internal control developments for attaining objective financial reporting practices. It can be concluded that the compatibility of commercial banks is significant in applying the proposed aspect of the moderator to attain the designed objective of the study. Accordingly, such implications can strengthen the resolutions and help make decisions for changes in the reporting practices of Iraqi commercial banks.

6. Conclusions

The present study was set up to reconceptualize and reform the current situation in the financial sector, especially in third-world banks. The study focused on the commercial banking sector, which is considered to be the backbone of the national economy of any nation. Thus, it was vital to investigate this sector to identify its strengths and weaknesses, which the present study highlighted regarding creative accounting and financial reporting practices. The previous studies showed the capability to incorporate some fraudulent practices within creative accounting, which directly impacts the quality of financial reporting. However, the literature review showed that the determinants of creative accounting could contribute to identifying some aspects of fraudulent practice that impact the quality of financial reporting. These findings were found to be consistent with the previous studies

that showed a high incidence of creative accounting practices in the financial banking sector, resulting in a low quality of financial reporting.

Therefore, the theoretical investigation had been conducted through the systematic literature review of the previous relevant studies. The intensive review of the literature contributed to identify the essential determinants of creative accounting, elements of financial reporting, and active aspects of transparency and disclosure in the research context, which impact reporting practice in the commercial banking sector. Additionally, the review contributed to the design of the present research questions and hypotheses in relation to the phenomenon of interest, while the practical application of the present study framework resolved various shortcomings identified in the previous studies through the moderating role of transparency and disclosure. As a result, the framework contributed to the attainment of the present research objectives. This study also makes several contributions for assessing and enhancing reporting practices in the financial sector and is especially authenticated as a valid model for use in the commercial banking sector.

Taken together, the present research findings showed that the degree of impact for creative accounting determinants is linked to the aspects of transparency and disclosure. This in turn was found to directly impact the quality of financial reporting practices in commercial banks, whereas the balanced use of these aspects can maintain diagnostic and interactive knowledge. Therefore, the level of creative practice may vary appreciably from one sector to another. This fact inspired the present study to adopt a triangulated application of agency, neo-institutional, and ownership theories to explain the correlation between the variable of the study and moderator, as shown in the designed conceptual framework. The results contributed concurrent evidence of the flexibility of creative accounting determinants with significant implications for the relationship between transparency and disclosure and financial reporting quality. In addition, the obtained findings strongly emphasized the significant impact of the moderator in the enhanced determination of creative practice as well as the strength and quality of financial reporting within the Iraqi commercial banks. The limitation of this research concerns the variables of the conceptual blueprint, which aimed to maintain a steady view in the diagnoses and interactions of the model in the commercial banks of Iraq. This design related to diverse factors in commercial banks, like the determinants of creative accounting practice and corporate governance changes, that may vary according to contemporary environmental opportunities or threats. Lastly, further research can be associated with the market valuation controversies to explain and address the ongoing debate regarding the banking markets. It may be essential to carry out further studies to understand how the deployment of corporate governance may support the determination of creative accounting practices in estimating market valuations of competitiveness.

Author Contributions: Conceptualization, I.A.A. and N.H.; methodology, I.A.A. and N.H.; formal analysis I.A.A., N.H., H.H., T.H.A. and M.A.A.; investigation, I.A.A., M.A.A. and N.H.; resources, I.A.A. and N.H.; writing—original draft preparation, I.A.A.; writing—review and editing, I.A.A., M.A.A. and N.H. All authors have read and agreed to the published version of the manuscript.

Funding: This research received no funding.

Institutional Review Board Statement: Not applicable.

Informed Consent Statement: Not applicable.

Data Availability Statement: Not applicable.

Acknowledgments: The authors are grateful to the Middle East University, Amman, and Zarqa University, Zarqa, Jordan for the financial support granted to cover the publication fee of this article. The authors also are grateful to the editor and the anonymous reviewers for providing very constructive and useful comments that enabled us to make additional efforts to improve the clarity and quality of our research.

Conflicts of Interest: The authors declare no conflict of interest, as the authors are the funders of this research.

Appendix A. Measurement Items

Transparency and Disclosure	
-	The bank has a transparent ownership structure.
-	The bank reports the accounting standard followed.
-	The bank exhibits full disclosure of corporate governance practices.
-	Bank annual report discloses information on the remuneration of members of the board of directors and executive staff.
-	Bank discloses the number of committee meetings held in that year and the members of the committee attending them.
Creative Accounting Determinants	
Ethical Issues	
-	The ethical issues prevalent in our bank do not affect the presentation of financial reporting.
-	Financial reports should be prepared and presented in accordance with the ethical guidelines of our bank.
-	Ethical standards are duly observed in the presentation of the financial reporting procedures in our bank.
-	The accountants in our bank are always objective in the presentation of financial reports.
-	The bank has revealed a code of conduct/ethics.
Disclosure Quality	
-	There are significant effects of the reports' disclosure on the quality of the financial reporting practice in our bank.
-	Disclosure practice is affected by the professional competence of the professional accountant.
-	The quality of disclosure practice for financial reporting is compliant with financial reporting standards.
-	Disclosure of internal control reports increases the auditory role.
-	The disclosure of financial reporting is affected by the professional accountant practice.
Internal Control	
-	The availability of continuous control reports in the bank can enhance the internal control functions which lead to improvements in the quality of financial reporting.
-	The existence of recommendations and advice about potential improvement in the reports leads to improvement in the quality of financial reporting.
-	The existence of matching and reasonableness reports for different periods in the reports lead to improvements in the quality of financial reporting.
-	Segregation of duties leads to improvement in the quality of financial reporting.
-	A clear determination for the responsibilities and authorities among departments leads to improvements in the quality of financial reporting.
Ownership Structure	
-	Our bank provides equal access to information for shareholders and investment analysts.
-	Ownership in our bank would be stronger since managers have more incentives to opportunistically exploit quality financial reporting.
-	The concentrated ownership in our bank can overcome the free-rider problem and enhance the quality of financial reporting by improving the monitoring of management.
-	In our bank's high ownership structure, controlling shareholders are less dependent on minority shareholders and may take benefits from them.
-	Ownership structure reflects the bank's decision to disclose high-quality information as a corporate governance practice to monitor managerial activities.

Financial Reporting Quality Dimensions	
Relevance	
-	The annual report discloses forward-looking information about the bank.
-	The bank uses fair values instead of historical precedents.
-	Cost in preparing financial statements.
-	Transparent statements help the development of expectations and predictions by users regarding the bank's future.
-	The presence of non-financial information in terms of business opportunities and risks complements financial information.
Faithful Representation	
-	The annual report highlights the positive and negative events in a balanced way when discussing the annual results.
-	Accounting principles are firmly followed in our bank.
-	The annual report extensively discloses information on corporate governance issues.
-	The annual report contains disclosure on environmental issues.
-	The annual report explains the choice of accounting.
Understandability	
-	The degree to which the annual report is well-organized.
-	The notes to the financial statements are clear.
-	The use of language and technical jargon is easy to follow in the annual report.
-	The annual report included a comprehensive glossary.
-	The use of graphs and tables in financial reports enhances the quality of financial reporting.
Comparability	
-	The notes to revisions in accounting estimates and judgments explain the implications of the revision.
-	The results of the current accounting period are compared with the results of previous accounting periods.
-	Information in the annual report is comparable to information provided by other organizations.
-	The annual report presents financial index numbers and ratios.
-	Industry comparison enhances the quality of financial reporting.

References

- Susmus, T.; Demirhan, D. Creative Accounting: A Brief History and Conceptual Framework. In Proceedings of the 3rd Balkans and Middle East Countries Conference on Accounting and Accounting History, Istanbul, Turkey, 19–22 June 2013.
- Idris, A.A.; Kehinde, J.S.; Ajemunigbohun, S.S.A.; Gabriel, J.M.O. The nature, techniques and prevention of creative accounting: Empirical evidence from Nigeria. *Can. J. Account. Financ.* **2012**, *1*, 26–31.
- Mulford, C.W.; Comiskey, E.E. Creative accounting and accounting scandals in the USA. *Creat. Account. Fraud. Int. Account. Scandal.* **2012**, 407–424.
- Mutuc, E.B.; Lee, J.-S.; Tsai, F.-S.; Bimo, I.D.; Siregar, S.V.; Hermawan, A.A.; Wardhani, R.; Kewo, C.L.; Afiah, N.N.; Bardhan, I.; et al. Avoiding creative accounting: Corporate governance and leadership skills. *SSRN Electron. J.* **2019**, *10*, 221–246.
- Hameedi, K.S.; Al-Fatlawi, Q.A.; Ali, M.N.; Almagtome, A.H. Financial Performance Reporting, IFRS Implementation, and Accounting Information: Evidence from Iraqi Banking Sector. *J. Asian Financ. Econ. Bus.* **2021**, *8*, 1083–1094.
- Anam Ousama, A.; Fatima, A.H.; Salihin, A. An Islamic perspective on the true and fair view override principle. *J. Islam. Account. Bus. Res.* **2014**, *5*, 142–157. [[CrossRef](#)]
- Goel, S. The quality of reported numbers by the management: A case testing of earnings management of corporate India. *J. Financ. Crime* **2014**, *21*, 355–376. [[CrossRef](#)]
- Škoda, M.; Lengyelfalussy, T.; Gabrhelová, G. Creative Accounting Practices in Slovakia after Passing Financial Crisis. *Copernic. J. Financ. Account.* **2017**, *6*, 71–86. [[CrossRef](#)]
- Ibrahim, S.S.H. The Impacts of Capital Structure on Bank Performance. *Koya Univ. J. Humanit. Soc. Sci.* **2019**, *2*, 118. [[CrossRef](#)]

10. Alsalim, M.; Amin, H.; Youssef, A. The role of corporate governance in achieving accounting information quality (field study in the mishraq sulfur state co.). *Stud. Sci. Res. Econ. Ed.* **2018**, *27*, 2–24. [CrossRef]
11. Uwuigbe, O.R.; Olorunshe, O.; Uwuigbe, U.; Ozordi, E.; Asiriuwa, O.; Asaolu, T.; Erin, O. Corporate Governance and Financial Statement Fraud among Listed Firms in Nigeria. In Proceedings of the IOP Conference Series: Earth and Environmental Science, Ota, Nigeria, 18–20 June 2019; Volume 331, p. 012055. [CrossRef]
12. Cooray, T.; Gunarathne, A.D.N.; Senaratne, S. Does corporate governance affect the quality of integrated reporting? *Sustainability* **2020**, *12*, 4262. [CrossRef]
13. Martin, R.; Yadiati, W.; Pratama, A.; Rubio-Misas, M.; Alshbili, I.; Elamer, A.A.; Beddewela, E.; Harun, M.S.; Hussainey, K.; Mohd Kharuddin, K.A.; et al. Doing Good with Creative Accounting? Linking Corporate Social Responsibility to Earnings Management in Market Economy, Country and Business Sector Contexts. *Sustainability* **2019**, *8*, 4568. [CrossRef]
14. Brauweiler, H.-C.; Yerimpasheva, A.; Bagalbayeva, Z.; Lari Dashtbayaz, M.; Salehi, M.; Safdel, T.; Agyei-Mensah, B.K.; Salin, A.S.A.P.; Ismail, Z.; Smith, M.; et al. Avoiding creative accounting: Corporate governance and leadership skills. *Zesz. Teor. Rachun.* **2019**, *12*, 9–19. [CrossRef]
15. Qian, W.; Hörisch, J.; Schaltegger, S.; Baalouch, F.; Ayadi, S.D.; Hussainey, K.; Agyei-Mensah, B.K.; Nagata, K.; Nguyen, P.; Daske, H.; et al. A study of the determinants of environmental disclosure quality: Evidence from French listed companies. *J. Clean. Prod.* **2015**, *22*, 1608–1619. [CrossRef]
16. Makhaiel, N.K.B.; Sherer, M.L.J. The effect of political-economic reform on the quality of financial reporting in Egypt. *J. Financ. Report. Account.* **2018**, *16*, 245–270. [CrossRef]
17. Esra, A.; Engin, D.; Atabay, E.; Dinç, E. Financial Information Manipulation and Its Effects on Investor Demands: The Case of BIST Bank. In *Contemporary Issues in Audit Management and Forensic Accounting*; Grima, S., Boztepe, E., Baldacchino, P.J., Eds.; Contemporary Studies in Economic and Financial Analysis; Emerald Publishing Limited: Bingley, UK, 2020; Volume 102, pp. 41–56. ISBN 978-1-83867-636-0. eISBN 978-1-83867-635-3.
18. Akpanuko, E.E.; Umoren, N.J. The influence of creative accounting on the credibility of accounting reports. *J. Financ. Report. Account.* **2018**, *16*, 292–310. [CrossRef]
19. Johl, S.K.; Kaur Johl, S.; Subramaniam, N.; Cooper, B. Internal audit function, board quality and financial reporting quality: Evidence from Malaysia. *Manag. Audit. J.* **2013**, *28*, 780–814. [CrossRef]
20. Rozidi, M.; Nor, N.A.M.; Aziz, N.A.; Rosli, N.A.; Mohaiyadin, N.M.H. Relationship between Auditors' Ethical Judgments, Quality of Financial Reporting and Auditors' Attitude towards Creative Accounting: Malaysia Empirical Evidence. *Int. J. Bus. Humanit. Technol.* **2015**, *5*, 81–87.
21. Abed, I.A.; Hussin, N.; Ali, M.A.; Nikkeh, N.S.; Mohammed, A. Creative Accounting Phenomenon in the Financial Reporting: A Systematic Review Classification, Challenges. *Technol. Rep. Kansai Univ.* **2020**, *62*, 1–10.
22. Salome, E.N.; Ogbonna, M.I.; Marcel, E.C.; Echezonachi, O.E. The effect of creative accounting on the job performance of accountants (auditors) in reporting financial statement in Nigeria. *Kuwait Chapter Arab. J. Bus. Manag. Rev.* **2012**, *33*, 1–30.
23. Kardan, B.; Salehi, M.; Abdollahi, R. The relationship between the outside financing and the quality of financial reporting: Evidence from Iran. *J. Asia Bus. Stud.* **2016**, *10*, 20–40. [CrossRef]
24. Tri Wahyuni, E.; Puspitasari, G.; Puspitasari, E. Has IFRS improved Accounting Quality in Indonesia? A Systematic Literature Review of 2010–2016. *J. Account. Invest.* **2020**, *21*, 19–44. [CrossRef]
25. Abed, I.A.; Hussin, N.; Ali, M.A.; Othman, R.; Mohammed, M.A. A Systematic Critical Review of Creative Accounting and Financial Reporting. *Technol. Rep. Kansai Univ.* **2020**, *62*, 5113–5130.
26. Amat, O.; Gowthorpe, C. Creative Accounting: Nature, Incidence and Ethical Issues. 2004. Available online: <https://ssrn.com/abstract=563364> (accessed on 12 July 2004).
27. Engelseth, P.; Kritchanhai, D. Innovation in healthcare services—Creating a Combined Contingency Theory and Ecosystems Approach. In Proceedings of the IOP Conference Series: Materials Science and Engineering, Denpasar, Indonesia, 29–30 August 2017; Volume 337, p. 012022. [CrossRef]
28. Remenarić, B.; Kenfelja, I.; Mijoč, I. Creative accounting—motives, techniques and possibilities of prevention. *Ekon. Vjesn.* **2018**, *31*, 193–199.
29. Tassadaq, F.; Malik, Q.A. Creative accounting and financial reporting: Model development and empirical testing. *Int. J. Econ. Financ. Issues* **2015**, *5*, 544–551.
30. Butala, A.; Khan, Z.U. Accounting Fraud at Xerox Corporation. *SSRN Electron. J.* **2011**, *16*, 81–89. [CrossRef]
31. Cletus, A.; Oghoghomeh, T. Ethics of Accounting Profession in Nigeria. *J. Bus. Econ.* **2014**, *5*, 1374–1382.
32. Yao, S.; Wang, Z.; Sun, M.; Liao, J.; Cheng, F. Top executives' early-life experience and financial disclosure quality: Impact from the Great Chinese Famine. *Account. Financ.* **2020**, *60*, 4757–4793. [CrossRef]
33. Gerwanski, J.; Kordsachia, O.; Velte, P. Determinants of materiality disclosure quality in integrated reporting: Empirical evidence from an international setting. *Bus. Strategy Environ.* **2019**, *28*, 750–770. [CrossRef]
34. Song, D.B.; Lee, H.Y.; Cho, E.J. The association between earnings management and asset misappropriation. *Manag. Audit. J.* **2013**, *28*, 542–567. [CrossRef]
35. Yasser, Q.R.; Al Mamun, A.; Ahmed, I. Quality of financial reporting in the Asia-Pacific region: The influence of ownership composition. *Rev. Int. Bus. Strategy* **2016**, *26*, 543–560. [CrossRef]

36. Paolone, F.; Magazzino, C. Earnings manipulation among the main industrial sectors. evidence from Italy. *Evid. Italy* **2014**, 253–261.
37. Pakurár, M.; Haddad, H.; Popp, J.; Khan, T.; Oláh, J. Supply chain integration, organizational performance and balanced scorecard: An empirical study of the banking sector in Jordan. *J. Int. Stud.* **2019**, *12*, 129–146. [CrossRef]
38. Ayagre, P.; Appiah-Gyamerah, I.; Nartey, J. The effectiveness of Internal Control Systems of banks. The case of Ghanaian banks. *Int. J. Account. Financ. Report.* **2014**, *4*, 377. [CrossRef]
39. D’Mello, S.R.; Cruz, C.N.; Chen, M.-L.; Kapoor, M.; Lee, S.L.; Tyner, K.M. The evolving landscape of drug products containing nanomaterials in the United States. *Nat. Nanotechnol.* **2017**, *12*, 523–529. [CrossRef] [PubMed]
40. Pakurár, M.; Haddad, H.; Nagy, J.; Popp, J.; Oláh, J. The impact of supply chain integration and internal control on financial performance in the Jordanian banking sector. *Sustainability* **2019**, *11*, 1248. [CrossRef]
41. Foster, B.P.; McClain, G.; Shastri, T. The auditor’s report on internal control & fraud detection responsibility: A comparison of French and U.S. users’ perceptions. *J. Account. Ethics Public Policy* **2013**, *14*, 221–257.
42. Bardhan, I.; Lin, S.; Wu, S.L. The quality of internal control over financial reporting in family firms. *Account. Horiz.* **2015**, *29*, 41–60. [CrossRef]
43. Bimo, I.D.; Siregar, S.V.; Hermawan, A.A.; Wardhani, R. Internal control over financial reporting, organizational complexity, and financial reporting quality. *Int. J. Econ. Manag.* **2019**, *13*, 331–342.
44. Abed, I.A.; Hussin, N.; Ali, M.A. Piloting the Role of Corporate Governance and Creative Accounting in Financial Reporting Quality. *Technol. Rep. Kansai Univ.* **2020**, *62*, 2–7.
45. Nagata, K.; Nguyen, P. Ownership structure and disclosure quality: Evidence from management forecasts revisions in Japan. *J. Account. Public Policy* **2017**, *36*, 451–467. [CrossRef]
46. Sahasranamam, S.; Arya, B.; Sud, M. Ownership structure and corporate social responsibility in an emerging market. *Asia Pac. J. Manag.* **2019**, *37*, 37–1192. [CrossRef]
47. Haddad, H.; Alkhodari, D.; Al-Araj, R.; Aburumman, N.; Fraij, J. Review of the Corporate Governance and Its Effects on the Disruptive Technology Environment. *Wseas Trans. Environ. Dev.* **2021**, *17*, 1001–1020. [CrossRef]
48. Alzoubi, E.S.S. Ownership structure and earnings management: Evidence from Portugal. *Australas. Account. Bus. Financ. J.* **2016**, *24*, 135–161. [CrossRef]
49. Kao, M.-F.; Hodgkinson, L.; Jaafar, A. Ownership structure, board of directors and firm performance: Evidence from Taiwan. *Corp. Gov. Int. J. Bus. Soc.* **2019**, *19*. [CrossRef]
50. Bao, S.R.; Lewellyn, K.B. Ownership structure and earnings management in emerging markets—An institutionalized agency perspective. *Int. Bus. Rev.* **2017**, *26*, 828–838. [CrossRef]
51. Tommasetti, R.; da Silva Macedo, M.; Azevedo de Carvalho, F.A.; Barile, S. Better with age: Financial reporting quality in family firms. *J. Fam. Bus. Manag.* **2019**, *10*, 40–57. [CrossRef]
52. Mudel, S. Creative Accounting and Corporate Governance—A Literature Review. 2015. Available online: <https://ssrn.com/abstract=2708464> (accessed on 28 December 2015).
53. Udin, S.; Khan, M.A.; Javid, A.Y. The effects of ownership structure on likelihood of financial distress: An empirical evidence. *Corp. Gov. Int. J. Bus. Soc.* **2017**, *17*. [CrossRef]
54. Abdallah, A.A.-N.; Ismail, A.K. Corporate governance practices, ownership structure, and corporate performance in the GCC countries. *J. Int. Financ. Mark. Inst. Money* **2017**, *46*, 98–115. [CrossRef]
55. Rose, J.M.; Mazza, C.R.; Norman, C.S.; Rose, A.M.; Desoky, A.M.; Mousa, G.A.; Arsov, S.; Bucevska, V.; Popa, A.; Blidi El, R.; et al. Transparency and disclosure, neutrality and balance: Shared values or just shared words? *Probl. Perspect. Manag.* **2017**, *8*, 63–87. [CrossRef]
56. Ahmed, H.; Hussain, S.; Masroor, N. Transparency, CSR Disclosure and the Financial Performance of Firms: A Case of Pakistan Stock Exchange. *Karachi Univ. Bus. Res. J.* **2020**, *1*, 1–10. [CrossRef]
57. Mohammadi, S.; Nezhad, B.M. The role of disclosure and transparency in financial reporting. *Int. J. Account. Econ. Stud.* **2015**, *3*, 60. [CrossRef]
58. Zaman, R.; Bahadar, S.; Kayani, U.N. Role of media and independent directors in corporate transparency and disclosure: Evidence from an emerging economy. *Corp. Gov. Int. J. Bus. Soc.* **2018**, *16*, 593–608. [CrossRef]
59. Duh, M.; Djokić, D. Transparency and Disclosure Regulations—A Valuable Component of Improving Corporate Governance Practice in Transition Economies. In *Social Responsibility and Corporate Governance*; Springer: Berlin/Heidelberg, Germany, 2020; pp. 193–228.
60. Ejiogu, A.; Ejiogu, C.; Ambituuni, A. The dark side of transparency: Does the Nigeria extractive industries transparency initiative help or hinder accountability and corruption control? *Br. Account. Rev.* **2019**, *51*, 100811. [CrossRef]
61. Lim, S.J.; White, G.; Lee, A.; Yuningsih, Y. A longitudinal study of voluntary disclosure quality in the annual reports of innovative firms. *Account. Res. J.* **2017**, *30*, 89–106. [CrossRef]
62. Oh, W.Y.; Chang, Y.K.; Martynov, A.; Hicheon, K.; Heechun, K.; Peggy, M.L. Ownership structure and the relationship between financial slack and R&D investments: Evidence from Korean Firms. *Organ. Sci.* **2011**, *19*, 283–297. [CrossRef]
63. Arthur, N.; Chen, H.; Tang, Q. Corporate ownership concentration and financial reporting quality: International evidence. *J. Financ. Report. Account.* **2019**, *17*, 104–132. [CrossRef]
64. Krejcie, R.V.; Morgan, D.W. Determining sample size for research activities. *Educ. Psychol. Meas.* **1970**, *30*, 607–610. [CrossRef]

65. Krejcie, R.V.; Morgan, D. Small-Sample Techniques. *NEA Res. Bull.* **1970**, *30*, 607–610.
66. Pearlson, K.E.; Saunders, C.S.; Galletta, D.F. *Managing and Using Information Systems: A Strategic Approach*; John Wiley & Sons: Hoboken, NJ, USA, 2019; ISBN 111956056X.
67. Sekaran, U.; Bougie, R. *Research Methods for Business: A Skill Building Approach*; John Wiley & Sons: Hoboken, NJ, USA, 2016; ISBN 1119165555.
68. DE JESUS, T.A.; PINHEIRO, P.; KAIZELER, C.; SARMENTO, M. Creative Accounting or Fraud? Ethical Perceptions Among Accountants. *Int. Rev. Manag. Bus. Res.* **2020**, *9*, 58–78. [[CrossRef](#)]
69. Aifuwa, H.O.; Embele, K.; Musa, S. Ethical Accounting Practices and Financial Reporting Quality. *EPRA Int. J. Multidiscip. Res.* **2018**, *4*, 31–44.
70. Salameh, R.S. What is the Impact of Internal Control System on the Quality of Banks' financial Statements in Jordan? *Acad. Account. Financ. Stud. J.* **2019**, *23*, 1–10.
71. Adebisi, W.K.; Olowookere, J.K. Ownership structure and the quality of financial reporting: Evidence from Nigerian deposit money banks. *Int. J. Econ. Commer. Manag.* **2016**, *IV*, 541–552.
72. Iqbal, M.; Javed, F. The moderating role of corporate governance on the relationship between capital structure and financial performance: Evidence from manufacturing sector of Pakistan. *Int. J. Res. Bus. Soc. Sci.* **2017**, *6*, 89–105.
73. Rashid, M.M. Financial reporting quality and share price movement-evidence from listed companies in Bangladesh. *J. Financ. Report. Account.* **2020**, *18*, 425–458. [[CrossRef](#)]
74. Hair, J.F.; Black, W.C.; Babin, B.J.; Anderson, R.E. *Multivariate Data Analysis Always Learning*; Pearson Education Ltd.: London, UK, 2013.
75. Byrne, B.M. Structural equation modeling with AMOS: Basic concepts, applications, and programming (multivariate applications series). *N. Y. Taylor Fr. Gr.* **2016**, *396*, 7384.
76. Gras, E.; Palacios Manzano, M.; Hernández Fernández, J. Investigating the relationship between corporate social responsibility and earnings management: Evidence from Spain. *BRQ Bus. Res. Q.* **2016**, *19*, 289–299. [[CrossRef](#)]
77. Shafer, W.E.; Poon, M.C.C.; Tjosvold, D. Ethical climate, goal interdependence, and commitment among Asian auditors. *Manag. Audit. J.* **2013**, *28*, 217–244. [[CrossRef](#)]
78. Qian, W.; Hörisch, J.; Schaltegger, S.; Baalouch, F.; Ayadi, S.D.; Hussainey, K.; Agyei-Mensah, B.K.; Nagata, K.; Nguyen, P.; Daske, H.; et al. Assessing Disclosure Quality: A Methodological Issue. *J. Mod. Account. Audit.* **2015**, *11*, 466–475. [[CrossRef](#)]
79. Mudel, S. A Study to Show the Relation between Creative Accounting and Corporate Governance. 2016. Available online: <https://ssrn.com/abstract=2710567> (accessed on 4 January 2016).
80. Raimo, N.; Vitolla, F.; Marrone, A.; Rubino, M. The role of ownership structure in integrated reporting policies. *Bus. Strategy Environ.* **2020**, *29*, 2238–2250. [[CrossRef](#)]
81. Han, S.; Amrah, M.R.; Obaid, M.M.; Qawqzeh, H.K.; Endut, W.A.; Rashid, N.; Mustafa, M. Ownership Structure and Financial Reporting Quality: Influence of Audit Quality Evidence from Jordan. *SSRN Electron. J.* **2019**, *8*, 2212–2220. [[CrossRef](#)]
82. Muraina, S.A.; Dandago, K.I. Effects of implementation of International Public Sector Accounting Standards on Nigeria's financial reporting quality. *Int. J. Public Sect. Manag.* **2020**, *33*, 323–338. [[CrossRef](#)]
83. Singla, C.; George, R.; Veliyath, R. Ownership structure and internationalization of Indian firms. *J. Bus. Res.* **2017**, *81*, 130–143. [[CrossRef](#)]
84. Aguilera, R.V.; Crespi-Cladera, R. Global corporate governance: On the relevance of firms' ownership structure. *J. World Bus.* **2016**, *51*, 50–57. [[CrossRef](#)]
85. Khlif, H.; Ahmed, K.; Souissi, M. Ownership structure and voluntary disclosure: A synthesis of empirical studies. *Aust. J. Manag.* **2017**, *42*, 376–403. [[CrossRef](#)]
86. Lari Dashtbayaz, M.; Salehi, M.; Safdel, T. The effect of internal controls on financial reporting quality in Iranian family firms. *J. Fam. Bus. Manag.* **2019**, *9*, 254–270. [[CrossRef](#)]
87. Ibrahim, H.A.M.; Abdul Hussain, M.; Abdullah, Q.M. The Impact of Creative Accounting Methods on the Quality of Accounting Information: A Field Study on the Financial Reports of Companies Listed in the Iraq Stock Exchange. *J. Manag. Sci.* **2017**, *10*, 14.
88. Ndebugri, H.; Tweneboah Senzu, E. Analyzing the Critical Effect of Creative Accounting Practice in the Corporate Sector of Ghana. 2017. Available online: <https://ssrn.com/abstract=3236965> (accessed on 10 January 2020).
89. Cernusca, L.; David, D.; Nicolaescu, C.; Gomo, B.C. Empirical Study on the Creative Accounting Phenomenon. *Studia Univ. Vasile Goldiş Arad Ser. Ştiinţe Econ.* **2016**, *26*, 63–87. [[CrossRef](#)]
90. Al-Hashemi, H.T. The effect of creative accounting practices on measuring and presenting accounting information in the financial statements—A comparative analytical study on a sample of the financial and industrial sectors listed on the Iraq Stock Exchange. *J. Ma'aen* **2020**. [[CrossRef](#)]
91. Kovalová, E.; Frajtová Michalíková, K. The creative accounting in determining the bankruptcy of Business Corporation. *SHS Web Conf.* **2020**, *74*, 1017. [[CrossRef](#)]
92. Goel, S. Earnings management detection over earnings cycles: The financial intelligence in Indian corporate. *J. Money Laund. Control.* **2017**, *20*, 116–129. [[CrossRef](#)]
93. Khanin, D.; Mahto, R. V Regulatory risk, borderline legality, fraud and financial restatement. *Int. J. Account. Inf. Manag.* **2012**, *20*, 377–394. [[CrossRef](#)]

94. Nawaz, T.; Haniffa, R. Determinants of financial performance of Islamic banks: An intellectual capital perspective. *J. Islam. Account. Bus. Res.* **2017**, *8*, 130–142. [[CrossRef](#)]
95. Barandak, S.; Mohammadi, F. The effect of Internal Control Weakness on the Asymmetrical Behavior of Selling, General, and Administrative Costs. *J. Account. Manag. Vis.* **2020**, *2*, 38–53.
96. Maskani, M.; Abdoli, M. Investigating the Effectiveness of Tournament incentive on Relationship between CEO Behavioral Bias with Internal Control Weakness in Companies listed in the Tehran Stock Exchange. *Financ. Manag. Strategy* **2020**, *8*, 135–155.
97. Ashrafi, M.; Abbasi, E.; Hosseini, S.A.; Etemadi, M.P.; Kim, H.; Lee, T.H.; Suprianto, E.; Suwarno, S.; Murtini, H.; Rahmawati, R.; et al. Client importance and earnings management: The moderating role of Audit Committees. *Iran. J. Financ.* **2020**, *30*, 125–156. [[CrossRef](#)]
98. Tang, Q.; Chen, H.; Lin, Z. How to measure country-level financial reporting quality? *J. Financ. Report. Account.* **2016**, *14*, 230–265. [[CrossRef](#)]
99. Muhannad; Hussein, M. Creative accounting practices and their reflection on the reliability of the data published in the financial statements An applied study on a sample of commercial banks in Iraq. *AL-Dananeer Mag.* **2017**, *1*, 12–23.
100. Oprean-Stan, C.; Stan, S.; Brătian, V.; Hanash, M.K.; Abbas, H.H.; Oprean-Stan, C.; Oncioiu, I.; Iuga, I.; Stan, S.; Okoye, E.; et al. Corporate Sustainability and Intangible Resources Binomial: New Proposal on Intangible Resources Recognition and Evaluation. *Sustainability* **2018**, *12*, 4150. [[CrossRef](#)]