



Article

# Linking Green Human Resource Practices and Sustainable Performance: The Mediating Role of Job Satisfaction and Green Motivation

Hany Hosny Abdelhamied <sup>1,2,\*</sup>, Ahmed Mohamed Elbaz <sup>2,3</sup> , Bassam Samir Al-Romeedy <sup>2</sup>   
and Tamer Mohamed Amer <sup>2</sup>

<sup>1</sup> School of Business and Law, Dar Alhekma University, Jeddah 22246, Saudi Arabia

<sup>2</sup> Faculty of Tourism and Hotels, University of Sadat City, Sadat City 32897, Egypt

<sup>3</sup> College of Economics and Business Administration, University of Technology and Applied Sciences, Salalah 324, Oman

\* Correspondence: habdelhamied@dah.edu.sa

**Abstract:** The purpose of this study was to investigate the influence of job satisfaction and green motivation as mediators of green human resource practices and sustainable performance in the hotel industry. In order to collect information in a quantifiable manner, a questionnaire was issued to the employees of Egypt's five- and four-star hotels. Perspectives of 333 employees working at 18 five- and four-star hotels out of forty-four hotels located in Greater Cairo were analyzed using the partial least squares structural equation model (PLS-SEM). The results supported the model's validity and demonstrated that green human resource practices had a beneficial effect on job satisfaction. In addition, the results suggested that job satisfaction and "green motivation" significantly contributed to sustainable performance. In addition, the results demonstrated that work satisfaction acted as a partial and full mediator between the variables of sustainable human resource practices and sustainable performance. The ramifications of theory and management are examined.

**Keywords:** green human resource practices; sustainable performance; job satisfaction; green motivation; hotels; Egypt



**Citation:** Abdelhamied, H.H.; Elbaz, A.M.; Al-Romeedy, B.S.; Amer, T.M. Linking Green Human Resource Practices and Sustainable Performance: The Mediating Role of Job Satisfaction and Green Motivation. *Sustainability* **2023**, *15*, 4835. <https://doi.org/10.3390/su15064835>

Academic Editors: Lóránt Dénes Dávid, Peter Szende and Martin Balázs Zsarnóczky

Received: 10 January 2023  
Revised: 27 February 2023  
Accepted: 28 February 2023  
Published: 9 March 2023



**Copyright:** © 2023 by the authors. Licensee MDPI, Basel, Switzerland. This article is an open access article distributed under the terms and conditions of the Creative Commons Attribution (CC BY) license (<https://creativecommons.org/licenses/by/4.0/>).

## 1. Introduction

The increasingly frequent extreme weather events and apparent permanence of climate change have put front and center the need to curb carbon emissions and reverse any man-made damage to the global environment. Sánchez-Medina and Díaz-Pichardo [1] stated that companies are regarded as socially responsible when they employ practices to reduce the adverse effects of their operations on the environment and general health. Companies may be motivated to employ environmental practices by several elements, including a desire to acquire a competitive edge, a need to reduce operational costs, and/or a goal of reducing their adverse environmental and social impacts [2]. Egypt is a well-known travel destination, with the hospitality and tourism sector's contribution to the GDP amounting to EGP 374.6 billion in 2017. Numerous risks have emerged in the workplace, impacting the efficacy and economic viability of numerous industries [3,4]. In this regard, the COVID-19 pandemic has significantly impacted several industries over the past two years, including the tourism and hotel industries [5], resulting in a drop in international travel. It is predicted that the anticipated rebound of the tourist and hospitality sectors will contribute around EGP 601 billion to the Egyptian GDP by 2028 [6]. With the increasingly evident effects of climate change being felt worldwide, the ever-growing Egyptian hotel industry is facing several challenges as they work to adopt environmentally sound practices throughout their daily operations. Normal daily hotel operations adversely affect the environment through the high consumption of both water and energy and the generation of large amounts of

waste [7]. To help address these issues, this study focused on the practices of employees of hotel departments whose operations have potentially high adverse environmental impacts, including the food and beverage and housekeeping departments.

According to [8], human resources are considered to be the most important asset of any business operation, setting the organization apart from its competitors. Through proper human resource management, professional development helps employees improve their performance. In line with this, the incorporation of the advocacy of sound environmental practices into human resource management can result in a reduction of the adverse effects of production on the environment [9,10]. Proper human resource management significantly influences the success of any approach to business operations that a company decides to adopt. Green human resource management (GHRM) is a new concept that denotes the extent to which a company adopts and creates green practices that would help preserve the environment.

Based on [11], the implementation of GHRM would promote attitudinal and behavioral environmental practices among employees that can enhance a company's environmental outcomes. This was reasserted by [12] who found a positive relationship between adopting GHRM and environmental outcomes. GHRM practices require major changes in production and manufacturing [13]. GHRM initiatives promote environmental practices, reducing environmental degradation and encouraging the protection of natural resources and renewal [14]. GHRM comprises a set of procedures, beginning with the hiring of candidates with environmental studies backgrounds who then undertake further employee selection, shortlisting those most qualified to implement environmentally sound policies and practices [15]. GHRM also involves providing necessary training that clarifies the company's environmental and social commitments and desired postures, as well as performance evaluations and rewards that give value to the company's goals of sustainable practices [13].

Longoni et al. (2018) has investigated the synergistic influence of GHRM practices on firm performance [16]. To the best of our knowledge, prior to the current study, few studies have studied the link between green human resource practices, green motivation, job satisfaction, and sustainable performance in a service setting, particularly in the Middle Eastern hotel sector. By extension, the impact of green human resource management practices on green motivation, job satisfaction, and sustainable performance in a Middle Eastern setting has not been studied. The impact of green human resource management strategies has been largely underestimated, both in general and in Middle Eastern countries. As well, the mediating roles of both job satisfaction and green motivation in the relationship between green human resource practices and sustainable performance have never been investigated in any context. Furthermore, the impact of green human resource practices on green motivation, job satisfaction, and sustainable performance had never been examined in the hospitality industry. We have dedicated the current study to filling these research gaps. We aimed to shed light on the mediating roles of both job satisfaction and green motivation in the link between green human resource practices and sustainable performance in the Egyptian hospitality industry by building and experimentally testing a comprehensive conceptual model. The current study aimed to assess the impact of green human resource practices on green motivation, job satisfaction, and sustainable performance; explore the impact of green motivation and job satisfaction on sustainable performance; and investigate the mediating effect of job satisfaction and green motivation on the relationship between green human resource management practices and sustainable performance.

Therefore, this work makes significant novel contributions to the literature and practice of the hospitality industry. Firstly, it gives readers a basic overview of green human resource practices and makes an attempt to recommend many green initiatives that human resource management in hotels should implement. Secondly, it elaborates on several green practices that may be introduced into hotel workplaces to achieve a variety of economic benefits and competitive advantages, but the study also investigates the impact of GHRPs on operational, social, and economic performance in the hospitality industry. Finally, this

study provides new insights on the effort of greening the hospitality industry in developing economies, such as Egypt.

### *1.1. Literature Review and Hypothesis Development*

According to [17], sustainability is an essential part of the tourism business. The same author further added that sustainable tourism aims to balance the economic, socio-cultural, and environmental dimensions in the tourism industry.

Most tourism and hotel organizations are now facing both internal and external pressures to prioritize environmental protection and provide environmentally sound services that ensure sustainability and customer safety. Such pressures have led these organizations to follow green trends and behaviors and adopt green human resource management (GHRM) practices [18,19], which are based on the integration of environmental management practices and human resource management practices [20]. Organizations focus on selecting and hiring employees who are environmentally conscious and have an awareness of green practices [21]. For an organization to be more attractive to environmentally conscious employees, it should work on building a “green reputation” [21]. Through GHRM, organizations should be able to attract employees with environmental values and attitudes consistent with their own values and attitudes [22,23]. Green training and development should be provided, with the aim of increasing environmental awareness and related skills and knowledge, as well as involving employees in setting environmental goals and evaluating their performance in accordance with pre-set environmental standards [24]. Ling et al. (2018) [25] pointed out that HRM practices, such as hiring and selection, training and development, and performance appraisal, affect employee morale and job satisfaction. Chan and Hawkins (2010) [26] stated that GHRM should not be solely regarded as part of a strategic plan to enhance the sustainable performance of organizations, but it should also be understood as a means of achieving positive outcomes for employees, including better job satisfaction.

GHRM also plays an effective role in enhancing sustainable performance through increased efficiency and effectiveness of operations, improving economic performance by reducing costs and increasing profits, as well as supporting social performance through employee participation and retention [27]. Ref. [15] added GHRM comprises a set of long-term goals that contribute to the sustainable performance as well as the social and economic effectiveness of organizations. Likewise, an organization’s interest in adopting GHRM enhances employee perceptions of environmental risks and raises green motivation, increasing staff commitment to environmental goals and initiatives [28]. Ref. [29] explained that satisfaction with an organization’s environmental policies and practices affects the environment-related behaviors of employees, which motivates them to perform green practices at work as their contribution towards achieving the organization’s environmental goals. This, in turn, is clearly reflected in the improved sustainability of the organization [29]. Ref. [30] demonstrated that adoption of GHRM enhances the green skills and knowledge of employees and encourages them to adopt environmental organizational citizenship behaviors, which in turn result in high sustainable performance.

### *1.2. The Relationship between Green Human Practices and Job Satisfaction*

GHRM may be defined as the use of HRM strategies that promote the sustainable use of the organization’s resources to achieve environmental sustainability [27]. Many scholars have indicated the importance of green practices and stated that the adoption of green practices in human resource management contributes to increased job satisfaction and reduced turnover [27,31]. While [32] demonstrated that GHRM provides better satisfaction, organizational citizenship behaviors, and commitment, ref. [33] found that GHRM positively affects employee job satisfaction in the hospitality industry.

### 1.3. The Relationship between Green Hiring and Selection and Job Satisfaction

Green hiring and selection are important practices of GHRM [11,34]. Green hiring and selection are described as the process of recruiting and selecting candidates who are aware of environmental issues and have a willingness and inclination to commit to positive environmental performance [35]. Green hiring also involves hiring candidates with knowledge, skills, and behaviors that match the environmental management systems within the organization [36]. Thus, green hiring and selection ensure that new employees understand an organization's green culture and share its green values [37], and the organization in turn benefits from the green knowledge, values, and behaviors of these new employees [38]. It has been highlighted that hiring and selection are clearly related to job satisfaction [31,39,40]. Additionally, ref. [41] indicated that green hiring and selection provides better job satisfaction and higher environmental commitment. Moreover, refs. [42,43] argued that there is a positive relationship between green hiring and satisfaction. Thus, we propose the following hypothesis:

**Hypothesis 1 (H1).** *Green hiring and selection positively affect job satisfaction.*

### 1.4. The Relationship between Green Training and Development and Job Satisfaction

Ref. [36] defined green training and development as the process of developing employees' working-methods related skills, including optimal use of resource, energy conservation, waste minimization, and reduction of environmental degradation. In this vein, ref. [44] clarified that training and development lead to the integration of human capital and the accumulation of knowledge, which ultimately affects the well-being and satisfaction of employees, hence employees can accomplish their tasks easily and without obstacles. Ref. [45] added that training and development affect job satisfaction. In this context, ref. [40] explained that green training and development represent an effective and dynamic practice that leads to employee retention and increased job satisfaction. Furthermore, ref. [21] contended that green training and development support green perceptions and enhance motivation through organizational support, increasing employee satisfaction, and in return, facilitating the implementation of green initiatives. Ref. [46] also declared that green training enhances employee satisfaction and leads staff to participate more actively in achieving environmental sustainability. Ref. [15] similarly found that green training helps to improve job satisfaction and enhance environmentally friendly employee behaviors. Refs. [42,47] reported a correlation between green training and GHRM on one hand, and with employee development, including job satisfaction, on the other hand. In line of this, ref. [48] concluded that green training increases employee job-satisfaction, as staff perceive such training as a form of organizational support. Therefore, we propose the following hypothesis:

**Hypothesis 2 (H2).** *Green training has a positive impact on job satisfaction.*

### 1.5. The Relationship between Green Performance Appraisal and Job Satisfaction

Ref. [36] argued that "green human resources practices are crucial in motivating employees to respond to the businesses' green aims. These practices involve implementing HR strategies to achieve environmental sustainability objectives and foster employee development, commitment, and engagement with these goals. In this vein, ref. [44] clarified that aims to achieve a balance between economic, social, and environmental sustainability and can provide long-term benefits to a company. Further the same author demonstrates that providing constructive feedback to employees is positively related to perceived career opportunities and perceived respect which, in turn, positively impacts job satisfaction. Ref. [39] found a positive relationship between the performance appraisal and overall job satisfaction. In this context, ref. [40] explained that green training and development and green performance appraisal represent an effective and dynamic practice that leads to

employee retention and increased job satisfaction. Furthermore, Ref. [46] declared that green training enhances employee satisfaction and leads staff to participate more actively in achieving environmental sustainability. Ref. [25] Similar findings found that green human resources practices helps to improve job satisfaction. Refs. [42,47] reported a correlation between green GHRM on employee development, including job satisfaction. In line with this, ref. [48] concluded that green training increases employee job satisfaction, as staff perceive such training as a form of organizational support. Therefore, we propose the following hypothesis:

**Hypothesis 3 (H3).** *Green performance positively affects job satisfaction.*

#### *1.6. The Relationship between Green Involvement and Job Satisfaction*

As organizations move towards adopting green practices, they should prioritize setting relevant roles and responsibilities for employees in accordance with their strategic plans in order to ensure their staff's 'green involvement'. Green involvement refers to the inclusion of employees in the development of environmental goals and the mechanisms of achieving and implementing them, as well as enhancing employee interest in environmental issues and initiatives, which would accordingly reflect in the organization's green performance [49,50] indicated that job satisfaction is clearly affected by employee involvement in setting an organization's goals. Ref. [51] also showed a relationship between employee involvement and job satisfaction. Ref. [47] explained that the practice of green involvement, as a part of GHRM, positively influences job satisfaction. Ref. [32] added that green involvement both enhances employee satisfaction and makes staff more committed to achieving environmental goals. Ref. [39], a study of the hospitality industry, reported a comparable impact of green involvement on job satisfaction. Ref. [2] explained that the participation of employees in setting environmental plans and performance standards makes them feel valued for their ideas, consequently leading to higher job satisfaction and deeper commitment to set plans and standards. So, we propose the following hypothesis:

**Hypothesis 4 (H4).** *Green involvement positively affects job satisfaction.*

#### *1.7. The Relationship between Job Satisfaction and Operational Performance*

Sustainable performance refers to a dynamic process in which an organization aims to achieve a set of short-term profit-related performance goals without compromising their present long-term social and environmental performance goals. Refs. [52–54] indicated that training and development are important to the achievement of employee satisfaction, which reflects in more effective and efficient performance of tasks [17]. Ref. [55] added that satisfied employees quickly accomplish their goals, tasks, and organizational goals. Ref. [56] stated that employee satisfaction has positive effects on the successful implementation of tasks. Refs. [57,58] reported that job satisfaction significantly leads to increased levels of operational performance. Ref. [59] also emphasized the strong and positive impact of job satisfaction on the operational performance leading to achievement of its objectives. Ref. [49] commented that an organization's keenness to achieve high levels of employee satisfaction makes staff more willing to work harder and put additional effort into performing their tasks more efficiently, which reflects better overall operational performance. Furthermore, ref. [2] stated that there is a relationship between satisfaction and productivity, as the higher the degree of employee satisfaction, the higher their productivity. Therefore, the following hypothesis is proposed:

**Hypothesis 5 (H5).** *Job satisfaction positively affects operational performance.*



### *1.8. The Relationship between Job Satisfaction and Social Performance*

An organization's social performance is measured in terms of its work ethics, corporate social responsibility-related activities, employment creation, and the organization's positive image and reputation. Social performance may be divided into internal social performance, involving the origination support of its employees, and external social performance, involving relationships with customers, the local community, and various governmental organizations [9,17]. Refs. [54,60] highlighted that providing for the essential needs of employees results in higher employee satisfaction and consequently enhances the social performance of an organization, thus strengthening its relationship with the surrounding community [17]. Ref. [2] reported that employee satisfaction significantly improves an organization's corporate social responsibility and consequently its image and reputation in the market. The same author added that improving the social performance of an organization and its role in society depends on the willingness of employees to carry out social activities, whether inside or outside the organization. This in turn depends on their degree of motivation and job satisfaction. Achieving a high level of job satisfaction contributes to increased performance of employees, and this leads to an improvement in the quality of services provided to customers, thus achieving their satisfaction and loyalty as well [61]. Ref. [44] stated that job satisfaction improves the social performance of organizations, resulting in an overall competitive advantage. Accordingly, we propose the following hypothesis:

**Hypothesis 6 (H6).** *Job satisfaction positively affects social performance.*

### *1.9. The Relationship between Job Satisfaction and Economic Performance*

The financial performance of an organization is measured in terms of cost efficiency, revenue generation, use of waste to generate revenue, and efficient use of resources [28]. Organizations seek to achieve environmental sustainability by reducing undesirable outputs from their operations, which also helps them to achieve economic sustainability [62]. Ref. [44] reported that job satisfaction significantly improves the financial performance of an organization. Ref. [63] concluded that general satisfaction with leadership style and work-life balance affects the economic performance of an organization. The financial performance of organizations is also closely related to the level of employee job satisfaction, the organization's policies, job security, and wages [64]. Ref. [55] explained that a satisfied employee is willing to put more effort into achieving an organization's goals and returning more profits and revenues. Ref. [65] highlighted that job security contributes to increased levels of employee satisfaction, which is reflected in increased staff performance and support of the organization's performance, especially financial performance, as they seek to reduce production costs to preserve the organization's capital. Therefore, we assume the following hypothesis:

**Hypothesis 7 (H7).** *Job satisfaction positively affects economic performance.*

### *1.10. The Relationship between Green Motivation and Sustainable Performance*

Many service sector organizations face problems dealing with sustainability challenges because of the lack of knowledge and skills for implementing sustainability in practice [17], which is why companies have started paying more attention to employee motivation as it has been shown to increase productivity [66]. Thus, a large number of organizations are now keen on motivating their employees to adopt green practices, as this would induce them to work harder to achieve environmental goals, which in turn would improve these organizations' overall environmental performance [67]. As motivated employees work harder to help implement environmental initiatives, a company's sustainable performance and competitive advantage are enhanced [61]. Ref. [15] stated that organizations that aim to enhance their sustainable performance should seek to implement GHRM practices that help 'green motivate' employees. These practices should help enhance green culture and

environmental awareness among employees, making them more committed to the implementation of environmental activities. This, in turn, is reflected in higher profits and thus a more enhanced sustainable performance [15]. Ref. [68] showed that positive employee perception of GHRM practices enhance motivation and commitment to practice environmental organizational citizenship behaviors. In addition, creating a work environment that supports involving employees in setting environmental goals and putting forward ideas and proposals on various environmental issues would mold their green attitudes and behaviors towards achieving these goals and implementing environmental sustainability initiatives. Such an inclusive work environment would also help in the achievement of other objectives of the organization, especially economic objectives [38,61,69] explained that motivating employees and increasing their desire to work and protect the environment advantageously leads to the achievement of organizational success, the rise in creativity and innovation, acceptance of change, increased productivity, and better performance (operational performance), which all finally reflect as increased profitability (financial performance). In addition, higher employee motivation to work and save the environment would lead to increased customer satisfaction due to the resultant outstanding customer service (social performance). Ref. [15] added that employing an environmentally motivated workforce contributes to the achievement of sustainable goals. Positive attitudes of employees towards the implementation of environmental goals leads to better adherence to sustainable practices and supporting management in achieving sustainable performance. Stated differently, green motivation of employees enhances their well-being, develops society, and consequently improves the social performance of the organization [15].

Other studies have reported on the impact of green motivation on operational performance. Ref. [70] indicated that motivating employees towards sustainability leads to environmental behaviors and creativity in the workplace. In line with this, ref. [34] added that motivating employees helps organizations to achieve their operational goals. Involving employees in environmental innovation leads to improved products and increased efficiency of operations [71]. Ref. [43] agreed and added that adopting environment-friendly ideas from employees would result in positive attitudes towards environmental issues. Staff would thus employ their best skills in dealing with environmental issues and attempt to avoid adversely affecting the environment in the workplace. Ref. [29] indicated that green-motivated employees make organizations more productive, efficient, and effective. Ref. [72] pointed out that encouraging the green motivation of employees enhances their green creativity and enables them to create sustainable products and services. So, we propose the following hypothesis:

**Hypothesis 8 (H8).** *Green motivation positively affects operational performance.*

The relationship between green motivation and social performance has also been examined by researchers. Ref. [73] indicated that employees interested in an organization's green programs are more committed and more strongly attached to the said organization. Ref. [61] stated that motivated employees contribute to the improvement of the social performance of their organization through better customer service, leading to increased customer satisfaction and loyalty. Refs. [61,74] also stated that motivated employees typically desire to implement useful community activities. Ref. [30] highlighted that green motivation enhances an organization's environmental citizenship behaviors and leads employees to take up volunteering in service of their organization, their colleagues, and the wider community. Hence, we propose the following hypothesis:

**Hypothesis 9 (H9).** *Green motivation positively affects social performance.*

The impact of green motivation on economic performance has also been examined in previous studies. Ref. [71] stated that involving employees in implementing green initiatives and innovations contributes to a clear reduction in costs. The commitment of employees to participate in environment-related activities improves their knowledge

and skills, and, in turn, improves the economic performance of the organization [16]. In addition, employing environmentally conscious employees with an interest in environmental issues, and engaging them in setting environmental goals would strengthen their commitment to environmental activities. Also, providing green training enhances staff capabilities, which leads to improving economic performance [16]. Ref. [38] added that an organization's financial performance is—in part—linked to employee motivation to follow environmentally oriented practices. So, we propose the following hypothesis:

**Hypothesis 10 (H10).** *Green motivation positively affects economic performance.*

## 2. Research Methodology, Research Population, and Sampling Technique

For the goals of this study, a quantitative approach was employed, and a questionnaire was used to collect data from the staff of five- and four-star hotels operating in Egypt. This study encompassed an investigation of the relationship between green human resource practices and sustainable performance, by assessing the mediating role of job satisfaction and green motivation in the hotel industry. To assess the aforementioned research hypotheses, the study collected data from employees working at 18 of the 44 five- and four-star hotels located in the Greater Cairo Area [75,76]. Respondents were from human resources, food and beverage, housekeeping, and front office departments, as described by the Egyptian Ministry of Tourism. Three-star and lower-star hotels were excluded from the study due to a lack of evidence of the implementation of environmental performance programs [77,78]. The English version of the survey was back-translated into Arabic and reviewed for accuracy by two experts. Data was collected via face-to-face contact, through the help of one assistant, from November 2021 to January 2022. The survey was distributed among employees of hotels that ran a GHRM system. Distribution was conducted using the convenience sampling technique. Respondents were assured that the information obtained by the survey was to be used for research purposes only and no feedback was to be given to employers. A total of 400 questionnaires were distributed to the target respondents. Of this number, a total of 346 questionnaires were returned. Among these, only thirteen returned questionnaires were deemed unusable, due to incompleteness. The final number of usable questionnaires stood at 333; an 83 per cent response rate.

## 3. Measurement

As mentioned above, this study employed a survey as the data-gathering instrument. Items of the survey were grouped into (i) GHRM practices [79,80]; (ii) green involvement [79]; (iii) job satisfaction [80,81]; and (iv) sustainable performance [13]. The questionnaire was fine-tuned through discussions with various managers of hotel departments who had more than three years of experience. The final version of the survey was divided into two main sections. The first section comprised a set of employee profile questions (i.e., gender, age, position, length of experience, and department) and a set of questions about the hotel (i.e., type of affiliation and classification).

In the second section, employees were asked to rate 47 items on a five-point Likert-type scale ranging from (1) “strongly disagree” to (5) “strongly agree” in order to evaluate their opinions regarding these 47 items. Survey questions are divided into nine constructs: green recruitment and selection process (5 items), green training and development (4 items), green performance (5 items), green involvement (4 items), job satisfaction (7 items), green motivation (5 items), operational performance (5 items), social performance (4 items), and economic performance (8 items).

## 4. Analysis

In this study, data analysis involved three key procedures: (i) checking data for incompleteness, (ii) coding data, and (iii) choosing the appropriate statistical tests. For the descriptive analysis, SPSS Version (26) was used to analyze GHRM practices, green



involvement, job satisfaction, and scale descriptively. Conversely, partial least structural equation modelling (PLS-SEM) was used to test the measurement and structural models.

## 5. Results

### 5.1. Respondents' Profile

Table 1 details the respondents' profiles. Of the 333 respondents who completed the questionnaire, 249 (85%) were male and 84 (15%) were female. With respect to the departments in which respondents were employed, 24.3% were from the reservations department; 24.0% were from the food and beverages department. In terms of work experience, 55.6% of participants had 5 to 10 years of experience; and 25.8% had 11 to 15 years of experience. Educational background varied, with 83.1% having completed a bachelor's degree, and a small 12.9% having completed a postgraduate degree. In terms of hotel type, 249 (74.8%) of participants worked for five-star hotels, while 84 (25.2%) worked for four-star hotels.

**Table 1.** Sample grouping.

Characteristics	Description	Frequency	%
Gender	Male	249	85
	Female	84	15
Hotel Classification	Five-star	249	74.8
	Four-star	84	25.2
Department	Food and Beverage	80	24
	Front Office	65	19.5
	Housekeeping	81	24.3
	Reservation	66	19.8
	Others	41	12.3
Work Experience	Below 5 years	23	6.9
	5–10 years	185	55.6
	11–15 years	86	25.8
	More than 15 years	39	11.7

### 5.2. Measurement Model Assessment

The outer model was assessed for the reliability and validity of the investigated reflective constructs, as recommended by [82,83]. All Cronbach's  $\alpha$  values (ranging from 0.768 to 0.935) surpassed the recommended value of 0.70 [82], while composite reliability (CR) values varied from 0.868 to 0.950, exceeding [84]'s value of 0.70, suggesting internal consistency and reliability. Table 2 shows the evaluation of the validity of the instruments. As the table shows, the average variance extracted (AVE) values are greater than the recommended value of 0.50 [84], indicating convergent validity. Discriminant validity was assessed by comparing the square root of each latent variable's AVE to its equivalent correlation among other components, as advocated by [85,86]. Results indicated an appropriate discriminant validity (see Table 2).

In addition, the new heterotrait monotrait (HTMT) ratio of associations was used to assess the instrument's discriminant validity [87,88] (see Table 3). Ref. [87] labelled discriminant validity as 'good' if the HTMT value stood at less than 0.90 and 'outstanding' if it stood at less than 0.85. The HTMT ratios did not meet such values for any of the constructs in this study, a finding that may need further investigation. Furthermore, the average block VIF (AVIF) stood at 3.552, signifying the absence of both multicollinearity [84] and common variance bias [87,89]. Based on the prior findings, the outer model was equally valid and acceptable. As a result, inner model analysis was then conducted.

**Table 2.** Measurement model of first order reflective variables.

1st Order Variables	$\alpha$	CA	AVE	Model Fit and Quality Indices
Green hiring and selection (GHS)	0.911	0.943	0.806	Average path coefficient (APC) = 0.336, $p < 0.001$
Green training and development (GTD)	0.862	0.916	0.785	Average R-squared (ARS) = 0.602, $p < 0.001$
Green performance (GPA)	0.895	0.935	0.827	Average adjusted R-squared (AARS) = 0.599, $p < 0.001$
Green involvement (GI)	0.768	0.868	0.689	Average block VIF (AVIF) = 3.552, acceptable if $\leq 5$ , ideally $\leq 3.3$
Job satisfaction (JS)	0.935	0.950	0.793	Average full collinearity VIF (AFVIF) = 4.911, acceptable if $\leq 5$ , ideally $\leq 3.3$
Green motivation (GM)	0.923	0.951	0.867	Tenenhaus GoF (GoF) = 0.682, small $\geq 0.1$ , medium $\geq 0.25$ , large $\geq 0.36$
Operational performance (OP)	0.902	0.928	0.720	Sympson’s paradox ratio (SPR) = 1.000, acceptable if $\geq 0.7$ , ideally = 1
Social performance (SP)	0.880	0.917	0.735	R-squared contribution ratio (RSCR) = 1.000, acceptable if $\geq 0.9$ , ideally = 1
Economic performance (EP)	0.927	0.943	0.733	Statistical suppression ratio (SSR) = 1.000, acceptable if $\geq 0.7$
				Nonlinear bivariate causality direction ratio (NLBCDR) = 1000, acceptable if $\geq 0.7$

Note:  $\alpha$  = Cronbach’s alpha; CA = composite reliability; AVE = average variance extracted.

**Table 3.** Construct validity assessment.

Construct AVEs	1	2	3	4	5	6	7	8	9
<b>AVEs</b>									
1. GHS	(0.898)								
2. GTD	0.878	(0.886)							
3. GPA	0.676	0.730	(0.909)						
4. GI	0.808	0.817	0.72	(0.830)					
5. JS	0.726	0.725	0.467	0.747	(0.890)				
6. GM	0.732	0.715	0.493	0.703	0.895	(0.931)			
7. OP	0.462	0.462	0.279	0.404	0.579	0.587	(0.848)		
8. SP	0.414	0.425	0.268	0.36	0.556	0.587	0.853	(0.857)	
9. EP	0.384	0.411	0.309	0.386	0.535	0.586	0.822	0.814	(0.856)
Construct HTMT	1	2	3	4	5	6	7	8	9
1. GHS									
2. GTD	0.986								
3. GPA	0.747	0.833							
4. GI	0.956	1.004	0.899						
5. JS	0.783	0.807	0.511	0.869					
6. GM	0.795	0.801	0.543	0.826	0.963				
7. OP	0.507	0.524	0.313	0.477	0.631	0.645			
8. SP	0.460	0.487	0.302	0.43	0.612	0.651	0.957		
9. EP	0.415	0.460	0.34	0.457	0.574	0.633	0.899	0.900	

### 5.3. Structural Model Assessment

A number of measurements, including the beta ( $\beta$ ),  $p$ -value,  $R^2$ , and effect sizes ( $f^2$ ), are typically used to examine an inner model [84]. Figure 1 illustrates the relevant results of examining the inner model of the current study. Green hiring and selection were both found to have positively and significantly impacted on job satisfaction ( $\beta = 0.24$ ;  $p < 0.01$ ). In addition, green training and development were found to have a positive impact on job satisfaction ( $\beta = 0.25$ ;  $p < 0.01$ ). A small effect of green performance on job satisfaction was demonstrated ( $\beta = 0.11$ ;  $p = 0.01$ ). Conversely, findings showed a strong influence of green involvement on job satisfaction ( $\beta = 0.42$ ;  $p < 0.01$ ), demonstrating that H1, H2, H3, and H4 are all supported.

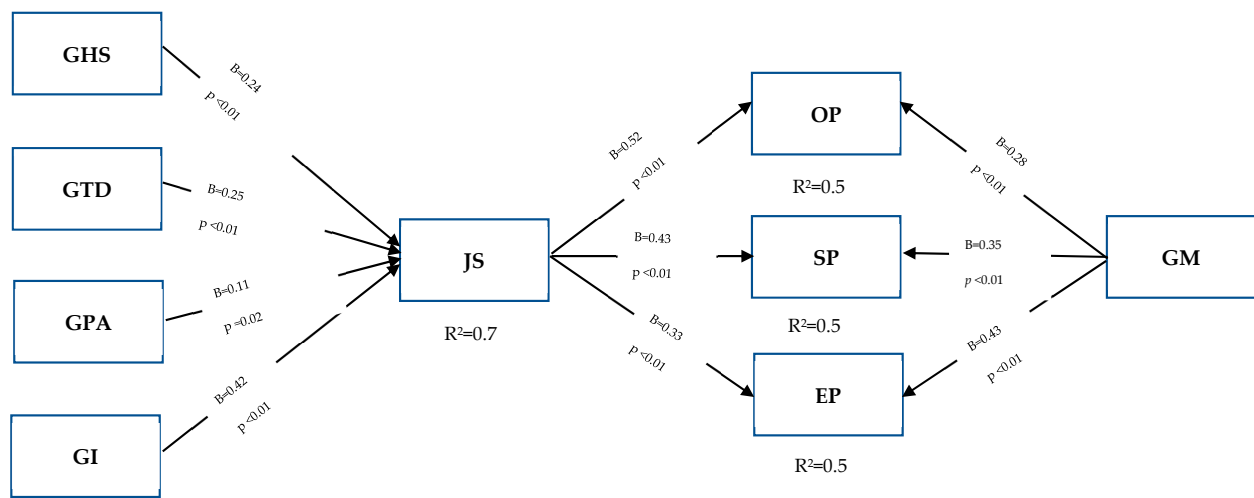

**Figure 1.** The structural Model.

The findings of the study also showed that job satisfaction had a positive and significant effect on operational performance ( $\beta = 0.52$ ;  $p < 0.01$ ), social performance ( $\beta = 0.43$ ;  $p < 0.01$ ), and economic performance ( $\beta = 0.33$ ;  $p < 0.001$ ). Hence, hypotheses H5, H6, and H7 are all supported by these findings. In addition, our findings demonstrated that green motivation had a positive and significant effect on operational performance ( $\beta = 0.28$ ;  $p < 0.01$ ), social performance ( $\beta = 0.35$ ;  $p < 0.01$ ), and economic performance ( $\beta = 0.43$ ;  $p < 0.001$ ), demonstrating support of H8, H9, and H10. In this vein, green hiring and selection, green training and development, green performance, and green involvement explained 73% of the variance in job satisfaction ( $R^2 = 0.73$ ), while job satisfaction and green motivation explained 59% of the variance in operational performance ( $R^2 = 0.59$ ), social performance ( $R^2 = 0.56$ ), and economic performance ( $R^2 = 0.53$ ). Based on these  $R^2$  values, it can be stated that the structural model has a significant explanatory power [87].

The criteria set by [84] were used to examine the research effect size ( $f^2$ ), with 0.02 denoting low effect, 0.15 denoting medium effect, and 0.35 denoting large impact. The findings revealed a moderate effect was evident in the association between green hiring and selection and job satisfaction ( $f^2 = 0.177$ ). Similarly, a moderate effect was recorded between green training and development and job satisfaction ( $f^2 = 0.181$ ), while a small effect was found between green performance and job satisfaction ( $f^2 = 0.055$ ). Lastly, a great effect was found between green involvement and job satisfaction ( $f^2 = 0.317$ ). The relationship between job satisfaction and operational performance was found to be great ( $f^2 = 0.389$ ). In addition, the relationship between job satisfaction and social performance was good ( $f^2 = 0.310$ ), and moderate ( $f^2 = 0.229$ ) with economic performance. The relationship between green motivation and operational performance was found to be moderate ( $f^2 = 0.203$ ), good ( $f^2 = 0.245$ ) with social performance, and great ( $f^2 = 0.302$ ) with economic performance.

#### 5.4. Mediation Analysis

As illustrated in Table 4, a mediation analysis was conducted to reveal the mediating role of job satisfaction in the link between green human resource practices (i.e., green hiring and selection, green training and development, green performance, green involvement) and sustainable performance (i.e., operational performance, social performance, economic performance). Results have demonstrated that job satisfaction fully mediated the link between GPA and OP, GI and OP, GTD and EP, and GPA and EP, and partially mediated the relationships between GHS and OP, GTD and OP, GHS and SP, GTD and SP, GPA and SP, GI and SP, GHS and EP, and GI and EP. In other words, the positive impact of green human resource practices on sustainable performance was principally mediated by job satisfaction, and these results were confirmed by [90].

**Table 4.** Indirect effect results.

Paths	Significance		Outcomes
	Direct Effect	Indirect Effect via Job Satisfaction	
GHS on OP	$p < 0.001$	$p < 0.001$	Partial Mediation at 5%
GTD on OP	$p < 0.001$	$p = 0.02$	Partial Mediation at 5%
GPA on OP	$p = 0.018$	$p = 0.18$	Full Mediation at 5%
GI on OP	$p < 0.001$	$p = 0.16$	Full Mediation at 5%
GHS on SP	$p < 0.001$	$p < 0.001$	Partial Mediation at 5%
GTD on SP	$p < 0.001$	$p = 0.011$	Partial Mediation at 5%
GPA on SP	$p = 0.023$	$p = 0.02$	Partial Mediation at 5%
GI on SP	$p < 0.001$	$p = 0.022$	Partial Mediation at 5%
GHS on EP	$p < 0.001$	$p < 0.001$	Partial Mediation at 5%
GTD on EP	$p < 0.001$	$p = 0.48$	Full Mediation at 5%
GPA on EP	$p = 0.028$	$p = 0.10$	Full Mediation at 5%
GI on EP	$p < 0.001$	$p < 0.001$	Partial Mediation at 5%

## 6. Discussion

The results showed that GHRPs had a significant and positive effect on JS. This result is comparable to the study by [40] who found a strong link between hiring and selection and job satisfaction. Ref. [39] also reported that job satisfaction was positively predictable by the practice of green hiring and selection. Additionally, the results of this study confirmed the positive influence for GTD on JS. This finding is in line with the results of a number of previous studies (e.g., [44]). For example, ref. [40] argued that green training and development leads to employee retention and increased job satisfaction. Similarly, refs. [48,91] explained that green training increases employee satisfaction as they realize it to be part of their professional development and regard it as one form of organizational support for employees. Moreover, it has been highlighted that green training clearly related to job satisfaction and performance [92,93].

The findings of the present study indicated that JS is positively predicted by GHRPs. This result is consistent with [42,94,95] who reported that green performance assessment increases job satisfaction. According to [46], green performance assessment has an impact on job satisfaction. Our findings indicated that GI had a strong impact on JS. This finding is in line with a number of previous studies. For example, refs. [47,93] reported that green involvement is connected to employee job satisfaction. Furthermore, refs. [32,39] said that green involvement increases employee satisfaction and dedication to environmental goals, accordingly green motivation is a significant predictor for job satisfaction.

Regarding the effect of job satisfaction on the three dimensions of sustainable performance, the findings of the present study indicated that JS positively affect OP. This result is in line with those reported by [57,58], whose research established a clear link between job satisfaction and operational performance. The findings of [59,96] likewise revealed the positive influence of job satisfaction on an organization's operational performance and

attainment of goals. The current study also showed that JS positively affects SP. This result is consistent with the work of [2], who stated that employee satisfaction is substantially connected to enhancing the organization's involvement in corporate social responsibility and boosting the organization's image and reputation in the market. According to [60], employee satisfaction improves organizational social performance through meeting employee needs and establishing relationships with the surrounding community. Moreover, the results also indicated that JS has a positive impact on EP. Our results indicate that the financial performance of an organization is significantly improved by higher job satisfaction; findings comparable to that of the work by [44], our results indicate that the financial performance of an organization is significantly improved by higher job satisfaction. Importantly, ref. [63] mentioned that satisfaction with leadership style, and a proper work-life balance have an impact on an organization's economic performance. Ref. [64] explained that organizational financial performance is also directly tied to employee job satisfaction, the organization's policies, job security, and compensation. These results support hypotheses H7, H6 and H5.

As for the effect of green motivation on the three dimensions of sustainable performance, the results of the current study highlight the positive impact of GM on OP. Comparable results were reported by a number of preceding studies, including that of [71] who demonstrated that engaging employees in environmental innovation leads to better services and higher operational efficiency. According to [29], green-motivated individuals make firms more productive, efficient, and successful. As explained by [72], boosting green motivations among employees increases their green creativity and allows them to build sustainable products and services. Results of this study also suggest that GM positively affect SP. This finding is in congruence with that of [30], who said that green motivation promotes environmental organizational citizenship behaviors and inspires employees to perform volunteer duties to the benefit of the organization, their colleagues, and the community. The findings of this study also suggest that GM has a positive impact on EP. This outcome is consistent with that reported by [71] who stated that including employees in the implementation of green initiatives and innovations contributes to a significant reduction in costs. According to [38], the financial performance of firms is connected to employee motivation to participate in environmentally friendly activities. Based on the previous discussion, it can be concluded that green motivation is a concrete motivator for employees to improve their performance and influence the economic performance of the hotels.

## 7. Theoretical and Managerial Implications

Drawing on the literature review, the roles of green human resource practices, green motivation, job satisfaction, and sustainable performance have been theorized and empirically demonstrated. A multitude of studies has shed the light on green practices targeting the enhancement of sustainable performance in hotels [35,97]. This study is multifaceted. Firstly, it empirically investigated the impact of green human resource practices, including GRS, GTD, GPA, and GI on JS, and explored the impact of JS on OP, SP, and EP. Secondly, it evaluated the effect of GM on OP, SP, and EP. Thirdly, it examined the mediating role of JS in the relationship between GHS, GTD, GPA, GI and OP, GHS, GTD, GPA, GI and SP, and GHS, GTD, GPA, GI, and EP

Several studies (e.g., [95,98]) highlighted the significant role of GHRPs, such as hiring and selection, training, and rewards and appraisal, in the greening of companies and improving environmental performance. GHRM practices are however still on the road to being fully adopted in developing countries. The current study contributes greatly to the knowledge of managers and practitioners in the hospitality industry. It asserts the importance of adopting environmental practices in hotels. Results of this study should be considered by decision makers in the hotel industry as well as government entities with which hotels interact, especially in developing countries. There are multiple sources of insight for hotel industry decision makers in this study. Firstly, this work provides a clear understanding of the GHRPs as described in existing literature, particularly in the context of the hotel industry in developing countries. It provides a clear technique of how hotels



can make use of GHRP practices in enhancing and improving their operations. Secondly, the emerging findings raised the importance of applying GHRPs in the development of environmental management concepts in hotels and hiring candidates with sufficient knowledge of environmental practices. Hiring candidates with prior knowledge of environmental practices would give hotels a competitive advantage, reducing operational costs and training costs. In addition, it accelerates the green transformation of these hotels [99]. Thirdly, the study investigated the relationships between GHRPs and sustainable performance in hotels and added evidence to the current literature on the positive correlations between GHRPs, job satisfaction, and the three pillars of sustainable performance (OP, SP, and EP). Thus, practitioners and hotel managers should enhance staff awareness of the positive effects of adopting and applying green practices on sustainable performance and environmental performance, in terms of cost reduction, waste reduction, recycling practices, and energy saving, along with the maintenance of a sustainable competitive edge for hotels adopting these practices [100].

The empirical research conducted in this study also illustrated the importance of green motivation as a strong mediator between GHRPs and sustainable performance. It was noticeable that GM greatly affects employee operational, social, and economic performances. The use of green motivation and job satisfaction as mediators add to the knowledge regarding how employees respond to GHRPs. Results indicate a strong effect of employee response to GHRPs on sustainable performance (OP, SP, EP) [101]. Hotels' activities result in the production of large amounts of waste and pollutants. For example, the food and beverages departments use a large amount of energy, which results in a large amount of carbon dioxide. Food production also results in a large volume of solid waste that constitutes an environmental hazard that hotels need to safely dispose of. Therefore, department managers, particularly of operational departments (housekeeping and food and beverages) should prioritize green motivation to accelerate the application of environmental management. Last, but not least, decision makers should consider the importance of adopting the GHRPs in both affiliated and independent hotels. This would lead to a green transformation of hotels, encouraging employees to apply green practices, and leading to enhanced sustainability performances.

## 8. Limitations and Future Research

Each and every scientific endeavor has certain constraints. Several constraints developed during the conduct of this investigation. Firstly, the questionnaire design lacked open-ended questions that would have allowed respondents to express their opinions regarding the relationship between GHRM practices and job satisfaction, green motivation, and sustainable performance. In addition, despite the fact that these study variables were specified and introduced as part of the questionnaire, there was no way for respondents to confirm their comprehension of the questions' wording or request clarifications. Consequently, the use of a completely quantitative questionnaire was one of the methodological constraints of this investigation. Future qualitative studies, such as interviews and focus groups, should provide a deeper understanding of the effects of GHRM practices on sustainable performance.

Secondly, this study is based on data collected from a sample of four- and five-star hotels in the Greater Cairo Area, comprised mainly of the governorate of Cairo and Giza City. It was logistically difficult to sample all hotels in Egypt, limiting those studied to a sample of those in the Greater Cairo Area. Moreover, restaurants, which also belong to the hospitality industry, were not included in this research. It is thus recommended that in-depth case studies be conducted in the hospitality and tourism industry to obtain more insight into the impact of GHRM practices on sustainable performance.

Thirdly, this study was conducted in the developing country of Egypt. It would be necessary to replicate this study in other developing countries and compare results.

Fourthly, a strategy of sampling by convenience was employed. Future studies should employ a random sampling method to generate a more statistically representative sample

of the population. Thus, the generalizability of this study is limited; random sampling would allow for greater generalizability of findings.

Fifthly, additional topics indicated for future research include the effects of green recruiting and selection, green training and development, green performance, green involvement, and green innovation on the green behavior of employees. Future research should study how GHRM methods may assist hotels in meeting consumer needs more successfully.

**Author Contributions:** Conceptualization, H.H.A. and A.M.E.; Methodology, H.H.A. and A.M.E.; Validation, H.H.A., A.M.E., B.S.A.-R. and T.M.A.; Formal analysis, B.S.A.-R.; Investigation, T.M.A.; Resources, T.M.A. All authors have read and agreed to the published version of the manuscript.

**Funding:** This research received no external funding.

**Informed Consent Statement:** Informed consent was obtained from all subjects involved in the study.

**Data Availability Statement:** All data were obtained through out questionnaire from hotels.

**Conflicts of Interest:** The authors declare no conflict of interest.

## References

1. Sánchez-Medina, P.; Díaz-Pichardo, R. Environmental pressure and quality practices in artisanal family businesses: The mediator role of environmental values. *J. Clean. Prod.* **2017**, *143*, 145–158. [CrossRef]
2. Al-Romeedy, B. Green human resource management in Egyptian travel agencies: Constraints of implementation and requirements for success. *J. Hum. Resour. Hosp. Tour.* **2019**, *18*, 529–548. [CrossRef]
3. Dan, H.S. Cultural differences as obstacles in the european economic integration process—a labour market perspective. *Online J. Model. New Eur.* **2015**, *15*, 76–96.
4. Dušek, J. How to Measure Intermunicipal Cooperation in Conditions of the Czech Republic. In *Modeling Innovation Sustainability and Technologies*; Springer: Cham, Switzerland, 2018; pp. 149–156.
5. Tittelbachová, Š.; Čajková, A.; Lukáč, M.; Lžičar, P. Impact of the COVID-19 pandemic on tourism in the Czech Republic. *Terra Econ.* **2022**, *20*, 133–145. [CrossRef]
6. Galal, S. Real Contribution of Travel and Tourism to GDP in Egypt 2012–2028. Tourism Statistics Annual Publications, Egypt. 2022. Available online: <https://www.statista.com/statistics/1010324/egypt-real-contribution-travel-tourism-gdp-egypt/> (accessed on 11 June 2022).
7. Graci, S.; Kuehnel, J. How to increase your bottom line by going green. In *Green Hotels & Responsible Tourism Initiative*; 2011; Available online: [Chrome-extension://efaidnbmnnnnibpcajpcgclefindmkaj/https://green.hotelscombined.com/Pages/MainGreen/Downloads/green-hotel-whitepaper.pdf](chrome-extension://efaidnbmnnnnibpcajpcgclefindmkaj/https://green.hotelscombined.com/Pages/MainGreen/Downloads/green-hotel-whitepaper.pdf) (accessed on 11 June 2022).
8. Wright, P.M.; Dunford, B.B.; Snell, S.A. Human resources and the resource based view of the firm. *J. Manag.* **2001**, *27*, 701–721.
9. Bhattacharya, A.; Mohapatra, P.; Kumar, V.; Dey, P.; Brady, M.; Tiwari, M.; Nudurupati, S. Green supply chain performance measurement using fuzzy ANP-based balanced scorecard: A collaborative decision-making approach. *Prod. Plan. Control* **2014**, *25*, 698–714. [CrossRef]
10. Al-Romeedy, B.; Moosa, S.; Elbaz, A. Does the Curricula of Tourism Studies in Higher Education Meet the Educational and Occupational Needs of the Tourism Labour Market? *Afr. J. Hosp. Tour. Leis.* **2020**, *9*, 1131–1143.
11. Bauer, T.; Erdogan, B.; Taylor, S. Creating and maintaining environmentally sustainable organizations: Recruitment and onboarding. In *Managing Human Resources for Environmental Sustainability*; Jackson, S.E., Ones, D.S., Dilchert, S., Eds.; Jossey-Bass/Wiley: New York, NY, USA, 2012.
12. Ambec, S.; Lanoie, P. Does it pay to be green? A systematic overview. *Acad. Manag. Perspect.* **2008**, *22*, 45–62.
13. Yong, J.; Yuliza, M.; Ramayah, T.; Fawehinmi, O. Nexus between Green Intellectual Capital and Green Human Resource Management. *J. Clean. Prod.* **2019**, *215*, 364–374. [CrossRef]
14. Jackson, S.; Renwick, D.; Jabbour, C.; Muller-Camen, M. State-of-the-art and future directions for green human resource management: Introduction to the special issue. *Ger. J. Hum. Resour. Manag.* **2011**, *25*, 99–116. [CrossRef]
15. Martins, J.; Aftab, H.; Mata, M.; Majeed, M.; Aslam, S.; Correia, A.; Mata, P. Assessing the Impact of Green Hiring on Sustainable Performance: Mediating Role of Green Performance Management and Compensation. *Int. J. Environ. Res. Public Health* **2021**, *18*, 5654.
16. Longoni, A.; Luzzini, D.; Guerci, M. Deploying environmental management across functions: The relationship between green human resource management and green supply chain management. *J. Bus. Ethics* **2018**, *151*, 1081–1095. [CrossRef]
17. Priatmoko, S.; Kabil, M.; Purwoko, Y.; Dávid, L.D. Rethinking sustainable community-based tourism: A villager’s point of view and case study in Pampang Village, Indonesia. *Sustainability* **2021**, *13*, 3245. [CrossRef]
18. Yusoff, Y.; Nejati, M.; Kee, D.; Amran, A. Linking green human resource management practices to environmental performance in hotel industry. *Glob. Bus. Rev.* **2020**, *21*, 663–680. [CrossRef]

19. Elsetouhi, A.M.; Mohamed Elbaz, A.; Soliman, M. Participative leadership and its impact on employee innovative behaviour through employee voice in tourism SMEs: The moderating role of job autonomy. *Tour. Hosp. Res.* **2022**, *22*, 1467358422119371.
20. Jabbour, C.; Jabbour, A. Green human resource management and green supply chain management: Linking two emerging agendas. *J. Clean. Prod.* **2016**, *112*, 1824–1833. [[CrossRef](#)]
21. Renwick, D.; Redman, T.; Maguire, S. Green human resource management: A review and research agenda. *Int. J. Manag. Rev.* **2013**, *15*, 1–14. [[CrossRef](#)]
22. Dumont, J.; Shen, J.; Deng, X. Effects of green HRM practices on employee workplace green behavior: The role of psychological green climate and employee green values. *Hum. Resour. Manag.* **2017**, *56*, 613–627. [[CrossRef](#)]
23. Abdelahmied, H. The impact of training activities on quality of service, customer satisfaction and behavioural intention. *Int. J. Tour. Hosp. Manag.* **2019**, *7*, 135–148.
24. Cherian, J.; Jacob, J. A study of green HR practices and its effective implementation in the organization: A review. *Int. J. Bus. Manag.* **2012**, *7*, 25–33. [[CrossRef](#)]
25. Ling, F.; Ning, Y.; Chang, Y.; Zhang, Z. Human resource management practices to improve project managers' job satisfaction. *Eng. Constr. Archit. Manag.* **2018**, *25*, 654–669. [[CrossRef](#)]
26. Chan, E.; Hawkins, R. Attitude towards EMSs in an international hotel: An exploratory case study. *Int. J. Hosp. Manag.* **2010**, *29*, 641–651. [[CrossRef](#)]
27. Shafaei, A.; Nejadi, M.; Yusoff, Y. Green human resource management: A two-study investigation of antecedents and outcomes. *Int. J. Manpow.* **2020**, *41*, 1041–1060. [[CrossRef](#)]
28. Shahzad, M.; Qu, Y.; Ur Rehman, S.; Zafar, A.; Ding, X.; Abbas, J. Impact of knowledge absorptive capacity on corporate sustainability with mediating role of CSR: Analysis from the Asian context. *J. Environ. Plan. Manag.* **2020**, *63*, 148–174. [[CrossRef](#)]
29. Malik, S.Y.; Hayat Mughal, Y.; Azam, T.; Cao, Y.; Wan, Z.; Zhu, H.; Thurasamy, R. Corporate Social Responsibility, Green Human Resources Management, and Sustainable Performance: Is Organizational Citizenship Behavior towards Environment the Missing Link? *Sustainability* **2021**, *13*, 1044. [[CrossRef](#)]
30. Anwar, N.; Mahmood, N.; Yusliza, M.; Ramayah, T.; Faezah, J.; Khalid, W. Green Human Resource Management for organizational citizenship behaviour towards the environment and environmental performance on a university campus. *J. Clean. Prod.* **2020**, *256*, 120401. [[CrossRef](#)]
31. Long, C.; Xuan, S.; Ismail, W.; Rasid, S.; Kowang, T. An Analysis on Academicians Job Satisfaction in the Perspective of HRD Practices. *Int. Educ. Stud.* **2014**, *7*, 85–95. [[CrossRef](#)]
32. Amrutha, V.; Geetha, S. Linking organizational green training and voluntary workplace green behavior: Mediating role of green supporting climate and employees' green satisfaction. *J. Clean. Prod.* **2021**, *290*, 125876. [[CrossRef](#)]
33. Bhatti, M.A.; Alyahya, M.; Juhari, A.S.; Alshiha, A.A. Green HRM Practices and Employee Satisfaction in the Hotel Industry of Saudi Arabia. *Int. J. Oper. Quant. Manag.* **2022**, *28*, 100–120.
34. Khan, N.; Bhatti, M.; Obaid, A.; Sami, A.; Ullah, A. Do green human resource management practices contribute to sustainable performance in manufacturing industry? *Int. J. Environ. Sustain. Dev.* **2020**, *19*, 412–432. [[CrossRef](#)]
35. Mousa, S.; Othman, M. The impact of green human resource management practices on sustainable performance in healthcare organization's: A conceptual framework. *J. Clean. Prod.* **2020**, *243*, 118595. [[CrossRef](#)]
36. Omune, L.; Nyang'au, S. Effect of green human resource management practices on employee work performance in selected public universities in south rift Kenya. *J. Hum. Resour. Manag.* **2021**, *3*, 501–514.
37. Jackson, S.; Seo, J. The greening of strategic HRM scholarship. *Organ. Manag. J.* **2010**, *7*, 278–290. [[CrossRef](#)]
38. Masri, H.; Jaaron, A. Assessing green human resources management practices in Palestinian manufacturing context: An empirical study. *J. Clean. Prod.* **2017**, *143*, 474–489. [[CrossRef](#)]
39. Moin, M.; Omar, M.; Wei, F.; Rasheed, M.; Hameed, Z. Green HRM and psychological safety: How transformational leadership drives follower's job satisfaction. *Curr. Issues Tour.* **2021**, *24*, 2269–2277. [[CrossRef](#)]
40. Sareen, D. Relationship between strategic human resource management and job satisfaction. *Int. J. Curr. Res. Life Sci.* **2018**, *7*, 1229–1233.
41. Renwick, D.W.; Jabbour, C.J.; Muller-Camen, M.; Redman, T.; Wilkinson, A. Contemporary developments in Green (environmental) HRM scholarship. *Int. J. Hum. Resour. Manag.* **2016**, *27*, 114–128. [[CrossRef](#)]
42. Wagner, M. 'Green' human resource benefits: Do they matter as determinants of environmental management system implementation? *J. Bus. Ethics* **2013**, *114*, 443–456. [[CrossRef](#)]
43. Ahmad, S. Green human resource management: Policies and practices. *Cogent Bus. Manag.* **2015**, *2*, 1030817. [[CrossRef](#)]
44. Elrehail, H.; Harazneh, I.; Abuhjeeleh, M.; Alzghoul, A.; Alnajdawi, S.; Ibrahim, H. Employee satisfaction, human resource management practices and competitive advantage: The case of Northern Cyprus. *Eur. J. Manag. Bus. Econ.* **2019**, *29*, 125–149. [[CrossRef](#)]
45. Schmidt, S. The relationship between job training and job satisfaction: A review of literature. *Int. J. Adult Vocat. Educ. Technol. (IJAVET)* **2010**, *1*, 19–28. [[CrossRef](#)]
46. Okechukwu, W. Influence of training and development, employee performance on job satisfaction among the staff. *J. Technol. Manag. Bus.* **2017**, *4*, 1–16.
47. Ahmad, I.; Umrani, W. The impact of ethical leadership style on job satisfaction: Mediating role of perception of Green HRM and psychological safety. *Leadersh. Organ. Dev. J.* **2019**, *40*, 534–547. [[CrossRef](#)]

48. Pinzone, M.; Guerci, M.; Lettieri, E.; Huisingh, D. Effects of 'green' training on pro-environmental behaviors and job satisfaction: Evidence from the Italian healthcare sector. *J. Clean. Prod.* **2019**, *226*, 221–232. [[CrossRef](#)]
49. Gaafar, H.; Elzek, Y.; Al-Romeedy, B. The Effect of Green Human Resource Management on Green Organizational Behaviors: Evidence from Egyptian Travel Agencies. *Afr. J. Hosp. Tour. Leis.* **2021**, *10*, 1339–1356. [[CrossRef](#)]
50. Guest, D. Human resource management, corporate performance and employee wellbeing: Building the worker into HRM. *J. Ind. Relat.* **2002**, *44*, 335–358. [[CrossRef](#)]
51. Wood, S.; Van Veldhoven, M.; Croon, M.; de Menezes, L. Enriched job design, high involvement management and organizational performance: The mediating roles of job satisfaction and well-being. *Hum. Relat.* **2012**, *65*, 419–445. [[CrossRef](#)]
52. Gadenne, D.; Mia, L.; Sands, J.; Winata, L.; Hooi, G. The influence of sustainability performance management practices on organizational sustainability performance. *J. Account. Organ. Chang.* **2012**, *8*, 210–235. [[CrossRef](#)]
53. Huang, W.R.; Su, C.H. The mediating role of job satisfaction in the relationship between job training satisfaction and turnover intentions. *Ind. Commer. Train.* **2016**, *48*, 42–52. [[CrossRef](#)]
54. Pereira, V.; Silva, G.M.; Dias, Á. Sustainability practices in hospitality: Case study of a luxury hotel in Arrábida Natural Park. *Sustainability* **2021**, *13*, 3164. [[CrossRef](#)]
55. McCue, C.; Gianakis, G. The relationship between job satisfaction and performance: The case of local government finance officers in Ohio. *Public Product. Manag. Rev.* **1997**, *21*, 170–191. [[CrossRef](#)]
56. KaštelanMrak, M.; GrudićKvasić, S. The mediating role of hotel employees' job satisfaction and performance in the relationship between authentic leadership and organizational performance. *Manag. J. Contemp. Manag. Issues* **2021**, *26*, 97–110.
57. Rodríguez, D.; Buyens, D.; Van Landeghem, H.; Lasio, V. Impact of lean production on perceived job autonomy and job satisfaction: An experimental study. *Hum. Factors Ergon. Manuf. Serv. Ind.* **2016**, *26*, 159–176. [[CrossRef](#)]
58. Nguyen, T. Impact of leader-member relationship quality on job satisfaction, innovation and operational performance: A case in Vietnam. *J. Asian Financ. Econ. Bus.* **2020**, *7*, 449–456. [[CrossRef](#)]
59. Eberegbe, G.; Giovanis, E. Exploring the impact of job satisfaction domains on firm performance: Evidence from Great Britain. *J. Appl. Econ. Bus. Res.* **2020**, *10*, 96–114.
60. Edmans, A. The link between job satisfaction and firm value, with implications for corporate social responsibility. *Acad. Manag. Perspect.* **2012**, *26*, 1–19. [[CrossRef](#)]
61. Nguyen, T. STEAM-ME: A novel model for successful Kaizen implementation and sustainable performance of SMEs in Vietnam. *Complexity* **2019**, *2019*, 6048195. [[CrossRef](#)]
62. Kemp, R.; Pearson, P. Final report MEI project about measuring eco-innovation. *UM Merit Maastricht* **2008**, *32*, 121–124.
63. Melián-González, S.; Bulchand-Gidumal, J.; López-Valcárcel, B. New evidence of the relationship between employee satisfaction and firm economic performance. *Pers. Rev.* **2015**, *44*, 906–929. [[CrossRef](#)]
64. Brown, J. The Relationship between Job Satisfaction and Economic Performance: A Multi-National and Longitudinal Examination. Ph.D. Dissertation, San Diego State University, San Diego, CA, USA, 2016.
65. Zaki, H.; Al-Romeedy, B. Job security as a predictor of work alienation among Egyptian travel agencies' employees. *Minia J. Tour. Hosp. Res.* **2018**, *3*, 47–64.
66. Peráček, T. Human Resources and Their Remuneration: Managerial and Legal Background. In Proceedings of the 13th International Scientific Conference on Reproduction of Human Capital—Mutual Links and Connection 2020, Prague, Czech Republic, 5–6 November 2020; pp. 454–465.
67. Kane, A. Green recruitment, development and engagement. In *Going Green: The Psychology of Sustainability in the Workplace*; Bartlett, D., Ed.; The British Psychological Society: Leicester, UK, 2011; pp. 6–17.
68. Kehoe, R.; Wright, P. The impact of high-performance human resource practices on employees' attitudes and behaviors. *J. Manag.* **2013**, *39*, 366–391. [[CrossRef](#)]
69. Winit, W.; Ekasingh, E.; Sampet, J. How Disclosure Types of Sustainability Performance Impact Consumers' Relationship Quality and Firm Reputation. *Sustainability* **2023**, *15*, 803. [[CrossRef](#)]
70. Jabbour, C.; Sarkis, J.; de Sousa Jabbour, A.; Renwick, D.; Singh, S.; Grebinevych, O.; Godinho Filho, M. Who is in charge? A review and a research agenda on the 'human side' of the circular economy. *J. Clean. Prod.* **2019**, *222*, 793–801. [[CrossRef](#)]
71. Bombiak, E.; Marciniuk-Kluska, A. Green human resource management as a tool for the sustainable development of enterprises: Polish young company experience. *Sustainability* **2018**, *10*, 1739. [[CrossRef](#)]
72. Li, W.; Bhutto, T.; Xuhui, W.; Maitlo, Q.; Zafar, A.; Bhutto, N. Unlocking employees' green creativity: The effects of green transformational leadership, green intrinsic, and extrinsic motivation. *J. Clean. Prod.* **2020**, *255*, 120229. [[CrossRef](#)]
73. Yen, C.; Chen, C.; Teng, H. Perceptions of environmental management and employee job attitudes in hotel firms. *J. Hum. Resour. Hosp. Tour.* **2013**, *12*, 155–174. [[CrossRef](#)]
74. Foster, B.; Muhammad, Z.; Yusliza, M.Y.; Faezah, J.N.; Johansyah, M.D.; Yong, J.Y.; ul-Haque, A.; Saputra, J.; Ramayah, T.; Fawehinmi, O. Determinants of pro-environmental behaviour in the workplace. *Sustainability* **2022**, *14*, 4420. [[CrossRef](#)]
75. Egyptian Ministry of Tourism and Antiquities. *Hotels Obtain Health Safety Certificate in Great Cairo*; Egyptian Ministry of Tourism and Antiquities Publications: Cairo, Egypt, 2021.
76. Elbaz, A.; Soliman, M.; Al-Alawi, A.; Al-Romeedy, B.; Mekawy, M. Customer responses to airline companies' service failure and recovery strategies: The moderating role of service failure habit. *Tour. Rev.* **2023**, *78*, 1–17. [[CrossRef](#)]



77. Rodríguez-Antón, J.; del Mar Alonso-Almeida, M.; Celemín, M.; Rubio, L. Use of different sustainability management systems in the hospitality industry, the case of Spanish hotels. *J. Clean. Prod.* **2012**, *22*, 76–84. [[CrossRef](#)]
78. Al-Azab, M.R.; Darwish, A.; Salem, I.E.; Elbaz, A.M. The Fear of COVID-19 Pandemic in Triggering Tourists' Material Deprivation, Social Rights, Social Participation, and Cultural Integration: The Mediating Role of Bullying. *Afr. J. Hosp. Tour. Leis.* **2020**, *10*, 1896–1915. [[CrossRef](#)]
79. Zaid, A.; Jaaron, A. Green Human Resource Management Bundle Practices and Sustainable Manufacturing Performance: Understanding Potential Relationships. *Int. J. Sci. Technol. Res.* **2020**, *9*, 7125–7132.
80. Shah, M. Green human resource management: Development of a valid measurement scale. *Bus. Strategy Environ.* **2019**, *28*, 771–785. [[CrossRef](#)]
81. Jamal, M.T.; Alalyani, W.R.; Thoudam, P.; Anwar, I.; Bino, E. Telecommuting during COVID 19: A moderated-mediation approach linking job resources to job satisfaction. *Sustainability* **2021**, *13*, 11449. [[CrossRef](#)]
82. Manley, S.; Hair, J.; Williams, R.; McDowell, W. Essential new PLS-SEM analysis methods for your entrepreneurship analytical toolbox. *Int. Entrep. Manag. J.* **2020**, *17*, 1805–1825. [[CrossRef](#)]
83. Al-Romeedy, B. Strategic Agility as a Competitive Advantage in Airlines—Case Study: Egypt Air. *J. Fac. Tour. Hotels-Univ. Sadat City* **2019**, *3*, 1–15.
84. Hair, J.; Howard, M.; Nitzl, C. Assessing measurement model quality in PLS-SEM using confirmatory composite analysis. *J. Bus. Res.* **2020**, *109*, 101–110. [[CrossRef](#)]
85. Fornell, C.; Larcker, D. Evaluating structural equation models with unobservable variables and measurement error. *J. Mark. Res.* **1981**, *18*, 39–50. [[CrossRef](#)]
86. Al-Romeedy, B.; Ozbek, O. The effect of authentic leadership on counterproductive work behaviors in Egyptian and Turkish travel agents: Workplace incivility as a mediator. *Afr. J. Hosp. Tour. Leis.* **2022**, *11*, 409–425.
87. Kock, N. *WarpPLS User Manual: Version 8.0*; Script Warp Systems: Laredo, TX, USA, 2022.
88. Salem, I.E.; Elbaz, A.M.; Al-Alawi, A.; Alkathiri, N.A.; Rashwan, K.A. Investigating the Role of Green Hotel Sustainable Strategies to Improve Customer Cognitive and Affective Image: Evidence from PLS-SEM and fsQCA. *Sustainability* **2022**, *14*, 3545. [[CrossRef](#)]
89. Al-Romeedy, B.; Mohamed, A. Does Strategic Renewal Affect the Organizational Reputation of Travel Agents Through Organizational Identification? *Int. J. Tour. Hosp. Manag.* **2022**, *5*, 1–22. [[CrossRef](#)]
90. Berber, N.; Gašić, D.; Katić, I.; Borocki, J. The Mediating Role of Job Satisfaction in the Relationship between FWAs and Turnover Intentions. *Sustainability* **2022**, *14*, 4502. [[CrossRef](#)]
91. Shah, S.; Jiang, Y.; Wu, H.; Ahmed, Z.; Ullah, I.; Adebayo, T. Linking Green Human Resource Practices and Environmental Economics Performance: The Role of Green Economic Organizational Culture and Green Psychological Climate. *Int. J. Environ. Res. Public Health* **2021**, *18*, 10953. [[CrossRef](#)] [[PubMed](#)]
92. Arulrajah, A.; Opatha, H.; Nawaratne, N. Green human resource management practices: A review. *Sri Lankan J. Hum. Resour. Manag.* **2015**, *5*, 1–16. [[CrossRef](#)]
93. Cowling, A.; Newman, K. Banking on people: TQM, service quality and human resources. *Pers. Rev.* **1995**, *24*, 25–40. [[CrossRef](#)]
94. Ahmed, A.; Hussain, I.; Ahmed, S.; Akbar, M. Performance appraisals impact on attitudinal outcomes and organizational performance. *Int. J. Bus. Manag.* **2010**, *5*, 62–68. [[CrossRef](#)]
95. Wahjono, S.; Marina, A.; Perumal, S.; Wardhana, A. The Impact of Performance Appraisal on Job Satisfaction with Quality of Supervisor-Employee as a Moderating variable at State Owned Company. *Int. J. Adv. Sci. Res. Dev.* **2016**, *3*, 224–237.
96. Bakotić, D. Relationship between job satisfaction and organizational performance. *Econ. Res.-Ekonom. Istraživanja* **2016**, *29*, 118–130. [[CrossRef](#)]
97. Yuan, H.; Su, M.; Zywiolok, J.; Rosak-Szyrocka, J.; Javed, A.; Yousaf, Z. Towards Innovation Performance of the Hospitality and Tourism Industry: Interplay among Business Ethics Diffusion, Service Innovation, and Knowledge-Sharing. *Sustainability* **2023**, *15*, 886. [[CrossRef](#)]
98. Al-Gasawneh, J.A.; AlZubi, K.N.; Anuar, M.M.; Padlee, S.F.; ul-Haque, A.; Saputra, J. Marketing performance sustainability in the Jordanian hospitality industry: The roles of customer relationship management and service quality. *Sustainability* **2022**, *14*, 803. [[CrossRef](#)]
99. Fisher, S.L.; Graham, M.E.; Vachon, S.; Vereecke, A. Guest Editors' Note: Don't miss the boat: Research on HRM and supply chains. *Hum. Resour. Manag.* **2010**, *49*, 813–828. [[CrossRef](#)]
100. Ellinger, A.; Ellinger, A. Leveraging human resource development expertise to improve supply chain managers' skills and competencies. *Eur. J. Train. Dev.* **2014**, *38*, 118–135. [[CrossRef](#)]
101. Elshaer, I.A.; Sobaih AE, E.; Aliedan, M.; Azazz, A.M. The effect of green human resource management on environmental performance in small tourism enterprises: Mediating role of pro-environmental behaviors. *Sustainability* **2021**, *13*, 1956. [[CrossRef](#)]

**Disclaimer/Publisher's Note:** The statements, opinions and data contained in all publications are solely those of the individual author(s) and contributor(s) and not of MDPI and/or the editor(s). MDPI and/or the editor(s) disclaim responsibility for any injury to people or property resulting from any ideas, methods, instructions or products referred to in the content.