

# THE INTERNATIONAL JOURNAL OF BUSINESS & MANAGEMENT

## Study in the Factors Affecting the Application of Strategic Management Accounting (SMA) and Impacts on the Operating Accomplishments in the Manufacturing Enterprises in BAC Kan Province, Vietnam

Dr. Vu Thi Quynh Chi

Lecturer, Thai Nguyen university of Economics and Business and Administration,  
Thai Nguyen Province, Vietnam

### **Abstract:**

*In this study, it aims to identify the factors affecting the application of strategy of managing accounting (SMA) and the impacts on the operating accomplishment of the manufacturing enterprises in Bac Kan province, Vietnam. This writing uses the regression model after having been certified by Cronbach Alpha measure and Exploratory Factor Analysis (EFA) and structural equation modeling to realize what the effects of each factor on the application of strategy of managing accounting are and its impacts on the outcomes of enterprises. The research results have shown that there are 04 factors as follows: company size, building a business strategy, the level of competition, and Accountants participating in making decisions that have a positive relation to the application of the SMA in the enterprises in Bac Kan province – Vietnam. At the same time, the results of model certification show that the application of SMA which is related positively to the results of operation of enterprises in Bac Kan province – Vietnam.*

**Keywords:** Factors affecting, Strategic management accounting (SMA), the operating accomplishment, manufacturing enterprises, BAC Kan province – Vietnam

## 1. Introduction

### 1.1. Research Overview

Nowadays, in the globally integrated business market, the manufacturing enterprises want to succeed that means they have to build a strategy for business appropriately so as to bring the effects for the operation of units. To achieve this aim, every enterprise starts taking notice of organizing the Strategic Management Accounting (SMA) because the SMA will help the enterprises join in the process of planning, control and access the operation of units. Assessment the application of SMA in enterprises attracted a numerous scientist: Typically, Bromwich and Bhimani (1994); Noordin and et al (2015)' Ohoh and Ajibolade (2017) and so on. The scientists supposed that the SMA can replace the traditional management accounting. Apart from performing the same work as the traditional management accounting does, the SMA provides the enterprises with new aspects so as to serve the strategies for business and spur the level of competition.

According to Bromwich (1990), the author suggested that the enterprises should apply the SMA to analyze the advantages of comparative levels, so that they can see the increasing number of producing products, compared to other industry competitors. The author also gave some convincing theses of the benefits that the SMA has supplied for the enterprises through the professional requirements for accountants. It means they not only are excellent at management accounting, but also know how to combine with a different field such as: Strategy management, Marketing, Forecast, analyzing the benefits of comparative levels. If the enterprises do well in operating the SMA, then it will contribute to the success for them greatly. Besides, Chenhall (2003) proved that when the enterprises use the SMA that will help develop the strategies for business on schedule, especially the enterprises will focus on the producing products in order to make comparison with the industry competitors. A typical study in Europe was Tillman and Goddard (2008) carried out doing a survey in the producing enterprises which had a small and medium scale. The author realized that using the SMA brought an effect which overcome their expectation.

Another study in Nigeria carried out doing a survey in 15 different producing enterprises of Emiaso and et al (2018), it showed that using the SMA in those enterprises had a positive impact on the results. Recently, Thapayom (2019) also conducted a survey of applying the SMA in 148 different producing enterprises in Thailand. The results proved that those producing enterprises had applied the SMA that had comparative advantages well, so that it had a positive effect on the final results of business in the units.

In Vietnam, Doan Ngoc Phi Anh (2012), with her work of study, the author proved that applying the SMA in the enterprises would help them gain the effects in business on two aspects of both finance and non-finance in Vietnam. Nguyen Thi Thanh Loan (2016), from her research result, the author confirmed that the SMA is part of management

accounting. According to the author, the SMA helped her company in the process of analyzing to forecast the business circumstance of the enterprise.

On the basis of overviewing the research materials, authors gave the role of information that the SMA provided in enact the policies of business. However, using the SMA in the enterprises has not been widely applied with as many modern techniques as the researchers expected (Ojra, 2014).

### 1.2. Strategic Management Accounting

In the SMA materials, the researchers who studied the SMA started analyzing from the strategy term. According Fred R. David (2006) showed that strategy is a means of gain a long-term goal of the enterprises. According American Institute of Certified Public Accountants (AICPA): Accounting is an art of taking note, categorizing meaningfully and in the currency of accounting events, events related to the financial situation of the units. Meanwhile, Management Accounting is a module of accounting information system that provides information related to revenue, expenses and forecast of revenue, expenses as well as other financial information of enterprises.

SMA is seen as an intersection approach between accounting and strategic management and accounting is considered the focus for the management of business strategy of enterprises. According to Ojua (2016), the SMA is the information system of the Management Accountant to assist managers in making decisions that focus on the strategy of each business when participating in business activities. Meanwhile, according to Ward (1992). SMA is an accounting for the purpose of corporate business strategy management.

Thus, up to now, there has not been a formally accepted concept of SMA. But we can see that the SMA has the following common points: *Firstly*, collecting information of the SMA not only within the enterprises but needs to be collected outside the companies (mainly from competitors who trade in goods in the area or in other countries); *Secondly*, the results of the SMA analysis are used for financial and non-financial purposes. In this study, according to the author, SMA is understood as the accounting information system of the management accounting to assist managers in making strategic business decisions. SMA will be a useful tool to help businesses grow in the current global economic integration and competitive context.

### 1.3. Accomplishments

According to Simon (1976), the operating accomplishments from the investor's perspective is the total value they have received from their investment in the business including both financial and non-financial values. Cameron (1986) put his thesis on the result that there is no concept of common accomplishment to all types of businesses, but must attach to specific circumstances to have the most accurate concept. Meanwhile, Otley (1999) said that the business accomplishment is the system of analytical criteria for managers in the process of operating business development. Therefore, in order to evaluate the performance of an enterprise, we need to consider each industry, each special area associated with the business strategy goals of the business

### 1.4. Manufacturing Enterprises in BAC Kan province

Bac Kan is the northern midland and mountainous province of Vietnam with favorable geographical conditions to develop many professions. Currently, the province has resources such as: forest resources, land, the whole province of Bac Kan has an area of afforestation of 369,784.67 ha; Mineral resources include (iron ore, lead ore, ...); Resources for tourism and culture. Thanks to endowed natural advantages as well as geographical location near Hanoi capital and the northern midland and mountainous provinces of Vietnam. In recent years, there have been many enterprises established in the province with many different business and production lines, especially the province has attracted many FDI capital sources from many countries around the world such as: Manufacturing factories of plywood and flooring of Le Chen Wood Vietnam company, LLC. Vietnam Misaki Company specialized in processing apricots, ginger, vermicelli and so on. According to the Bac Kan Statistical Yearbook (2019), by the end of 2019, the whole province had 612 enterprises. Recently, according to the Report No. 164 / BC-SKHDT of the Department of Planning and Investment of Bac Kan province on June 19, 2020. In June 2020, there were about 824 enterprises in Bac Kan province, so the number of newly established enterprises in the first 6 months of 2020 increased rapidly. Manufacturing enterprises have played a great role in the development of industrialization and modernization of Bac Kan province. To do that is thanks to the participation of the People's Committee of Bac Kan province and departments regularly directing and having drastic policies in the management of production enterprises as well as policies to support businesses which is small to develop. Recently, the province has also issued many policies to support loans and reduce loan interest rates for businesses to encourage development of production enterprises. Specifically, on July 17, 2020, the People's Council of Bac Can province issued Resolution No. 10/2020 / NQ-HDND on supplementing a number of contents on policies to support the development of agricultural production in Bac Kan province and the Resolution No. 08/2019 / NQ-HDND dated 17 July 2019 of the People's Council of Bac Kan province.

From the comprehensive study and the current situation of manufacturing enterprises in Bac Kan province, it shows that enterprises apply strategic management accounting at a very low level, which is one of the reasons that limit the opportunities to create initiatives for production and decisions to help businesses gain a competitive advantage with other businesses in the country as well as in the world. Therefore, in this study, the author wants to measure the factors affecting the application of strategic management accounting and its impact on the performance of manufacturing enterprises in Bac Kan province. On that basis, proposing solutions to help businesses realize the importance as well as the influence of the SMA on the operating accomplishment of the enterprises in the future.

## 2. Theoretical Basis and Research Model

### 2.1. The Selected Theories for Research

*Preventive theory*, the first to apply this theory to research in the field of accounting is Hofstede (1967), followed by Cadez and Guilding (2008), Islam and Hu (2012). According to this theory, if we want to apply the SMA in the business, we must analyze and assess the business environment as well as the product characteristics that the enterprise produces. In the study, the author uses this theory to determine the factor of Company size that affects the application of SMA in the enterprise to help the unit implement the business strategy more effectively.

*Representative theory*, theory appeared in the 1970s and many scientists applied this theory to their research. According to Islam and Hu (2012), in order to reduce the tensions and conflicts of enterprises in the competition process, it is necessary to have a contract to bond the responsibilities to each other. In the contract, there should be provisions that require the contracting parties to report in detail on the operation of the business through the management accounting report in general and the SMA report in particular. Besides, the terms of contracts should regulate the interests of the parties to create motivation for them to perform the contract most effectively. Therefore, thanks to this theory, the author determines the accounting factors involved in making strategic decisions, business strategies, the level of competition to the ability to apply the SMA in the manufacturing enterprises.

*Information processing theory*, according to Galbraith (1973), Valanciene and Gimzauskiene (2007) have applied this theory for their research. The results of scientists have shown that in today's fiercely competitive business environment, businesses need to measure their multi-dimensional performance to provide continuous information to operate business activities. joint more efficient. Therefore, in the research scope, the author applied the theory to determine the factors of applying SMA that affect the business performance of manufacturing enterprises in Bac Kan province, Vietnam.

### 2.2. Research Model

Based on the research results of Khandwalla (1972), Holloway (2006), Fowzia (2011) and Ojra (2014), Ezzamel (1990); Gordon and Miller (1976), Cinquini and Tenucci, (2010), Abernethy and Bouwens (2005), Aver and et al (2009), Doan Ngoc Phi Anh, (2012) and inherited research by Bui Thi Truc Quy (2020), at the same time, from qualitative research results through interviews with experts, it is possible to generalize 04 factors affecting the application of SMA in the manufacturing sector with all types of scale of manufacturing enterprise in Bac Kan province in Vietnam.

#### 2.2.1. Company Size

Khandwalla (1972) argued that scale is the size of a particular business or organization. The author supposed that the breadth of this organization is assessed on two aspects: the scope of activities and the authority of that organization. Besides, according to Ojra (2014) and Luther and Longden (2001), the authors' research results have shown that company size (enterprise size) affects the application of SMA through joint policies related to the organization, design and use of techniques to apply SMA in the business. Agreeing with this point of view is that Haldma and Laats (2002) have given evidence to confirm that corporate governance accounting is affected by company size. Therefore, the SMA is the management accounting information system will also be affected by changes in size in the business.

#### 2.2.2. Build a Business Strategy

According to Ngo Kim Thanh (2012), building a business strategy is the process of making plans as well as the work that businesses need to do to achieve their business goals. Mintzberg (1987) thought that the business strategy of a business should experience 5 steps (plan, model, position, intention, vision). One of the authors who discovered the relationship between building business strategy with the application of SMA had an impact on each other was Fisher (1995). According to the author to evaluate the construction of business strategy, analysts need information from management accounting (analytical information related to business strategy) to compare and analyze the competitive advantages of enterprises. Therefore, building business strategies has an impact on the application of SMA in the business.

#### 2.2.3. The Level of Competition

According to Hwang (2005), Huang and et al. (2010) said that businesses in the process of operation would have to regularly compete with their competitors in terms of products, designs, product quality, and human skills, technological lines and so on. If the pressure is stronger, then the competition will become fierce and vice versa (Ezzamel, 1990). According to the researchers, in order to maintain operations and develop the business, administrators need to analyze information about competitors as well as the advantages of the unit to make the most effective decisions. To have the best accurate information of the business and the competitors, it is necessary to apply the SMA and the benefits that can be returned to the business are enormous. Research by Doan Ngoc Phi Anh (2012) also showed that the more competitive enterprises are, the greater the ability to operate the SMA for Vietnamese enterprises is.

#### 2.2.4. Accountants Participating in Making Strategic Decisions

Kaplan (1984) found that traditional management accounting is not capable of actively participating in the achievement of strategic objectives. It is this author's point of view that has raised a hot topic of participating researchers. In 1991, Oliver (1991) found the SMA employee to act as an indispensable part of organizational decision-making processes. Followed by scientists, Brouthers and Roozen (1999), Cadez and Guilding (2008), Aver et al (2009) had similar views on the role of accountants in advising home information. Management issues strategic business decisions both in the

short and long term. The results of these studies also open up future studies on the work of an accountant is how to participate in the strategic decision-making process affects the business performance of an organization.

### 3. Research Methodology

Based on a review of research documents and theoretical bases related to the topic, the author proposes a research model of factors affecting the application of SMA and the impact on operational performance of manufacturing enterprises in Bac Kan province in Vietnam include 04 factors as follows: (1) Company size; (2) Building a business strategy; (3) The level of competition, (4) The accountant participating in making strategic decisions with a positive relationship to the use of SMA in manufacturing enterprises. From the above arguments, the hypotheses for the research model are proposed as follows:

- Theory 1: Company size has a positive impact on the SMA application in manufacturing enterprises in BAC Kan province in Vietnam.
- Theory 2: Building a business strategy that has a positive effect on the application of SMA in manufacturing enterprises in BAC Kan province in Vietnam.
- Theory 3: The level of competition has a positive impact on the application of SMA in manufacturing enterprises in BAC Kan province in Vietnam.
- Theory 4: The accountant participating in making a strategic decision that has a positive influence on the application of SMA in manufacturing enterprises in Bac Kan province in Vietnam.
- Theory5: The application of SMA has a positive impact on the performance of manufacturing enterprises in Bac Kan province in Vietnam.

The research model is shown in figure 1 below:

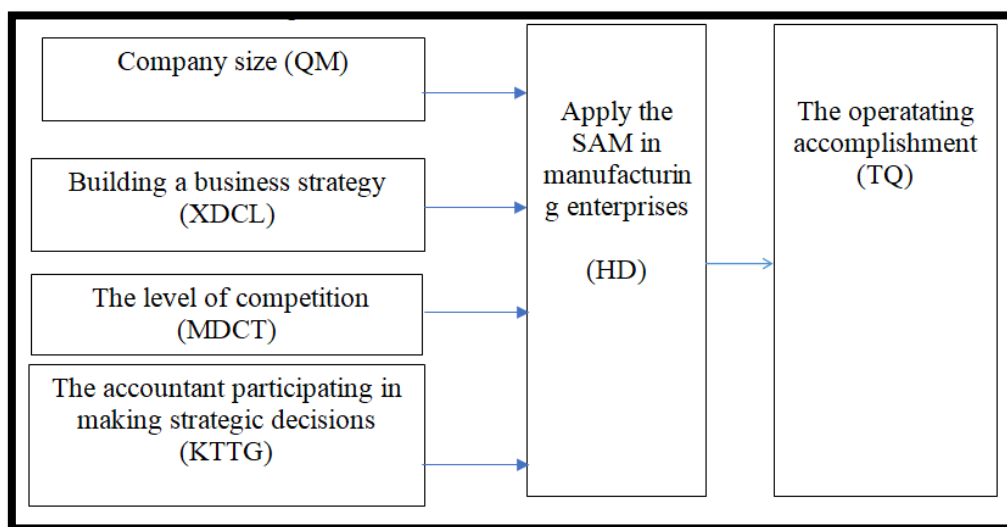

Figure 1: Research Model  
Source: The Author Suggested

To accomplish the research objectives, the author used a deductive approach, which is based on the theory of previous studies and qualitative research results through expert interview to propose the model. At the same time, in combination with the inductive method to verify and supplement observed variables in the questionnaire to perform quantitative research. Inheriting the research results of Nguyen Dinh Tho (2012), Hoque and James (2000), Mintzberg (1979), Tuan Mat (2010), Mintzberg (1987a), Wooldridge and Floyd (1990) and Bui Thi Truc Quy (2020) combining the use of qualitative research methods through interviews with experts, the author used 4 factors affecting the application of SMA in manufacturing enterprises in Bac Kan province in Vietnam

Next, the author conducted the survey through 25 observed variables and was measured by the 5-point Likers scale, the lowest point is 1 (least impact) and the highest point is 5 (very large effect) (Table 1).

Variable Code	Observed Variables
Company size (QM)	
QM1	The total revenue of the enterprise
QM2	Charter capital
QM3	The total value of assets on the balance sheet
Building a business strategy (XDCL)	
XDCL1	Strategy is analyzed before acting
XDCL2	Recognise its slowness and no error
XDCL3	In the enterprise, acting the strategy is frequently developed under the circumstance of having no intentions.
The level of competition (MDCT)	
MDCT1	Compete on raw material
MDCT2	Compete on human resource
MDCT3	Compete on sale and distribution
MDCT4	Compete on product quality/ services
MDCT5	Compete on the diversity of products/services
MDCT6	Compete on price
MDCT7	Compete on others sides
The accountant participating in making a strategic decision (KTTG)	
KTTG1	Accountants participating in determine the issues and goals
KTTG2	Accountants joining in assessing the options
KTTG3	Accountants participating in developing the project in detail.
KTTG4	Accountants perform the necessary activities in order to make changes necessarily.
To apply the SMA in manufacturing enterprises (HD)	
HD1	To manage the all-round quality and manage according to the operation.
HD2	Balanced scorecard
HD3	Product life cycle
HD4	Value chain analysis
Accomplishment (TQ)	
TQ1	Return on investment and sales profit
TQ2	Use the human resource
TQ3	Customer's satisfaction
TQ4	Product quality
TQ5	Develop new products

Table 1

The method of data collection is done through the survey; the subjects of the survey are the accounting people, the sales department, the marketing department and the business leaders in BAC Kan province in Vietnam.

According to Hair et al. (2006), for the survey in the EFA model, the minimum sample size must be 5 times as much as the total number of observed variables. So,  $N = 5 \times 25 = 130$  observed samples. At the same time, Hair et al. (2010) emphasizes the particularly important role of preliminary quantitative research in SEM research. To ensure the statistics as well as ensure the reliability of the answers, the author gave out 250 survey papers, collected 240 votes, after checking the information on the questionnaire there were 235 votes to ensure sufficient information to enter data and perform analysis. Of the 235 surveys collected, 155 are males, accounting for 65.9%, and the rest are females. In which, there are 98 people working as director and deputy director, accounting for 41.7%; 90 accounting, management accounting for 38.29%, the rest are 47 sales staff, marketing department accounting for 20.0%.

In this study, the author uses the EFA discovery analysis method, CFA confirmation factor analysis and SEM multi-structure model analysis using SPSS20 software to determine the relationship between factors that affect the applying the SMA and affecting the performance of manufacturing enterprises in Bac Kan province in Vietnam.

## 4. Research Results and Discussions

### 4.1. Results of Cronbach's Alpha test

To conduct factor analysis, first of all, it is necessary to test the reliability of the scale through Cronbach's Alpha coefficients and total variable correlation coefficients. For scales with Cronbach's Alpha coefficients  $\geq 0,6$  we can accept and variables with total variable correlation coefficients less than 0.3 will be disqualified.

Research results show that, Cronbach's Alpha coefficient for the scale of the largest components is 0.884 and the smallest is 0.686. Thus, all Cronbach's Alpha coefficients are  $> 0,6$  and variables with total variable correlation  $> 0,3$ , so all scales of the factors are reliable (Nunnally & Burnstein, 1994). Thus, the variables ensure the requirements to conduct factor analysis to discover EFA.

#### 4.2. Factor Analysis Results (EFA)

We have, coefficient KMO = 0.813, which shows that the data is suitable to be able to conduct EFA analysis. Besides, we have Pvalue value of Bartlett test equal to 0, i.e., the variables are correlated with each other on the overall scale.

Also, through the discovery factor analysis EFA, we have the variance extracted to reach 64.564%, this means that the extracted factor explains 64.564% of the variation. Thus, exploratory factor analysis (EFA) is suitable for the data and the observed variables are correlated in the population (Gerbing & Andersen, 1998), and should be used for further analysis.

	Factor					
	1	2	3	4	5	6
MDCT1	.945					
MDCT5	.908					
MDCT3	.882					
MDCT2	.868					
MDCT7	.838					
MDCT4	.776					
MDCT6	.742					
TQ1		.995				
TQ3		.887				
TQ2		.757				
TQ4		.723				
TQ5		.693				
HD4			.888			
HD1			.750			
HD3			.721			
HD2			.679			
KTTG1				.797		
KTTG4				.779		
KTTG2				.725		
KTTG3				.701		
DXCL3					.919	
DXCL1					.863	
DXCL2					.761	
QM1						.939
QM3						.704
QM2						.697

Table 2: The Analysis Results of Factors  
Source: The Author Suggested

After rotating the factor, we have 6 groups of factors.

- The *first* group of factors includes observed variables: MDCT1, MDCT5, MDCT3, MDCT2, MDCT7, MDCT4, and MDCT6. We name the group as Competitiveness, denoted by MDCT.
- The *second* group of factors includes observed variables: TQ1, TQ3, TQ2, TQ4, TQ5. We name the group is Activity Achievement, denoted by China.
- The *third* group of factors includes observed variables: HD4, HD1, HD3, and HD2. We named the group Apply SMA in manufacturing enterprises, symbolized by HD.
- The *fourth* group of factors includes the observed variables: KTTG1, KTTG4, KTTG2, KTTG3. We name the group as Accountants involved in strategic decision making, denoted by KTTG.
- The *fifth* group of factors includes observed variables: DXCL3, DXCL1, DXCL2. We name the group as Building business strategy, symbolized by XDCL.
- The *sixth* group of factors includes observed variables: QM1, QM3, QM2. We name the group as Company Size, symbolized by QM.

#### 4.3. Results of Confirmatory Factor Analysis (CFA)

The results of confirmatory factor analysis (CFA) show that the standardized regression weights of all variables are greater than 0.5, proving that the model achieves convergent values, the criteria for evaluation of the model's compatibility with indicators such as CMIN / DF, GFI, CFI, TLI and RMSEA to consider. The analytical results showed that CMIN / DF = 1,875 < 2. In addition, the indexes GFI = 0.913, CFI = 0.965, TLI = 0.946, these indexes are all greater than 0.9. RMSEA index = 0.054 < 0.08. Therefore, this shows that the suitability of the data is appropriate.

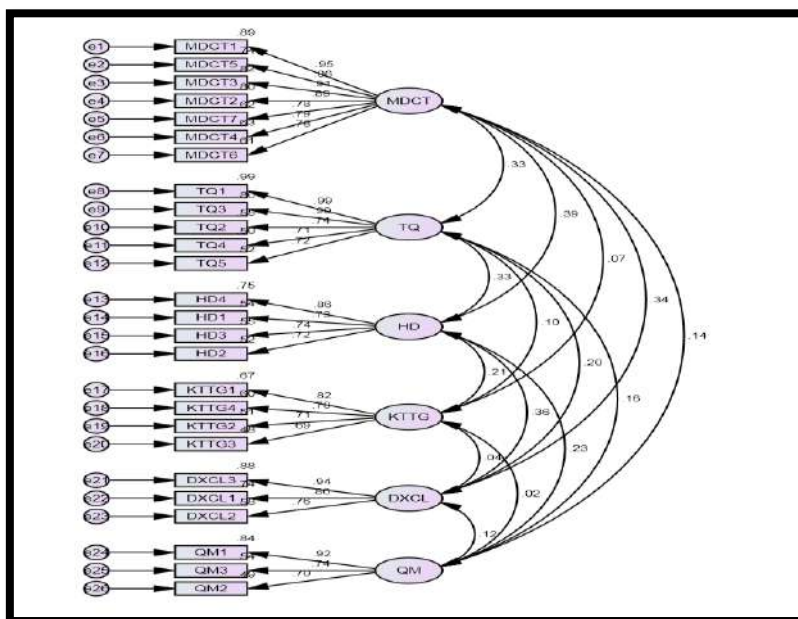

Figure 2: CFA Analysis Results  
Source: According To Author's Calculations

4.4. Results of Linear Structure Model (SEM)

From the results of confirmatory factor analysis, we have  $CMIN / DF = 1,902 < 2$  and the indexes  $GFI = 0.984$ ,  $CFI = 0.936$ ,  $TLI = 0.930$  are all greater than 0.9,  $RMSEA = 0.062 < 0.08$ . Thus, the data are consistent.

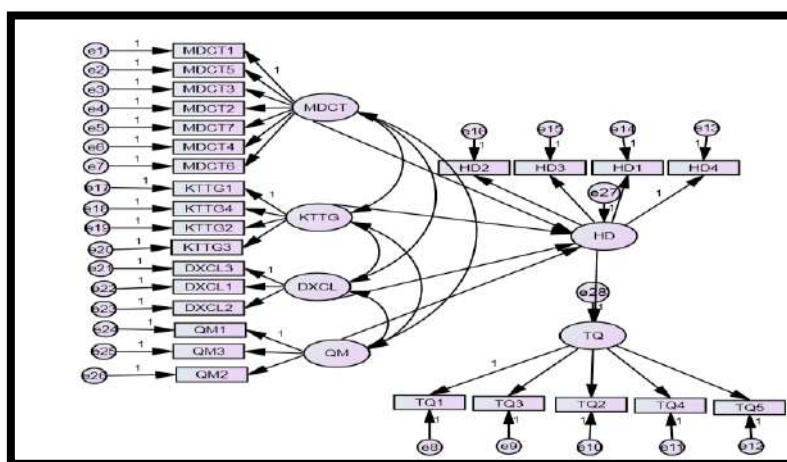

Figure 3: Linear Structure Analysis SEM  
Source: According to Author's Calculations

Next, we will examine the hypothesis to study the factors affecting the application of SMA in manufacturing enterprises that affect the operational performance of the unit.

			Estimate	S.E.	C.R.	P
HD	<---	MDCT	.327	.079	4.127	.000
HD	<---	KTTG	.177	.067	2.633	.008
HD	<---	DXCL	.237	.068	3.490	.000
HD	<---	QM	.187	.080	2.346	.019
TQ	<---	HD	.392	.077	5.089	.000

Table 3: Results of Testing the Relationships between Concepts in the Theory Models  
Source: According to Author's Calculations

Through the above results table, we have hypothesized relationships in the research model which are all proved by the SEM model test. Estimation results show that the weights are positive sign (+) and are statistically significant. This means that groups of factors have a positive impact with the application of SMA in manufacturing enterprises.

#### 4.5. Verify the Reliability of Estimates Using Bootstrap

The Bootstrap method was used to test the model estimates in the final model with the repeating sample N = 500. Estimated results from 500 samples were averaged with bias as shown below:

Parameter			SE	SE- SE	Mean	Bias	SE-Bias	CR
HD	<---	MDCT	.093	.003	.333	.006	.004	0
HD	<---	KTTG	.069	.002	.175	-.002	.003	-0,5
HD	<---	DXCL	.078	.002	.231	-.006	.003	0
HD	<---	QM	.099	.003	.185	-.002	.004	0,75
TQ	<---	HD	.092	.003	.393	.001	.004	0,166

Table 4: The Estimated Results Using the Bootstrap with N= 500)

Source: According to Author's Calculations

In this study, the author performed Bootstrap by repeating samples with size N = 500. Estimated results from 500 samples were averaged with bias shown in the table above showing the bias (Bias) and the standard deviation of the deviation (SE-Bias) appears but not large. The value of CR <2 should be able to confirm a very small bias and not statistically significant at 95% confidence that the estimates in the model are reliable.

## 5. Conclusions and Recommendations

Through the analytical results, we can see a positive impact, which is statistically significant, consists of 04 factors; (1) Company size; (2) Building a business strategy; (3) The level of competition, (4) The accountants involved in the making of strategic decisions that all affect the application of SMA and the performance of the manufacturing enterprises in Bac Kan Province in Vietnam. Based on the research results, the authors propose some of the following recommendations:

*Firstly*, the research results show that the variable Company Size (QM) has a positive impact with the variable Apply the SMA in manufacturing enterprises (HD). For large-scale manufacturing enterprises, it is an advantage to help the company apply the SMA more successfully. Thus, manufacturing enterprises in general and manufacturing enterprises in Bac Kan province in particular need to pay attention to expanding the company size by increasing the number of employees, increasing sales of goods and providing services. Also, it is necessary to increase the value of total assets shown on the annual financial statements of the business. As the scale becomes larger, businesses have more opportunities to access modern analytical methods to help make business plans more effective. One of the analytical tools that bring a lot of value is the application of SMA in the business of the enterprises.

However, manufacturing businesses should not be too subjective, businesses should have policies to control the increase in size due to real development, not virtual growth. For example, if the number of employees is large, the manufacturing enterprise needs to consider whether the employees are doing their best or not, whether the company is exploiting their full capabilities or not. If not, enterprises must consider cutting down on ineffective employees that adversely affect the development of the enterprise, a reasonable number of employees will help to apply the SMA more effectively.

*Secondly*, the Factors of Building business strategies and the level of competition have a positive impact on Applying SMA in manufacturing enterprises (HD). This means that the method of the more appropriate manufacturing enterprises to build and choose a business strategy and the level of competition are, the more effective the ability to apply SMA is. Because the SMA is closely linked to the business strategy and the level of competition, so when the business strategy and the level of competition change, the SMA system will have to change as well. Managers need to establish long-term product strategies to meet the needs of the market and customers, and seek for additional raw materials to limit dependence on a certain material. By doing so, manufacturing enterprises must be proactive in accessing research and forecast information to review and adjust the given strategy accordingly. Therefore, it will bring safety to the level of competition of the business during the production process.

*Thirdly*, as we know that financial accounting is a compulsory regulation for businesses in Vietnam, however, management accounting only encourages enterprises to apply it. Therefore, the research results have shown that the factor of Accountants participating in the Quality Decision has a positive impact with the variable Apply the SMA in manufacturing enterprises (HD).

This means that when accountants participate in information provision, analyze information and process information related to the business strategy of the business that affects the business performance of the unit. Therefore, managers should pay more attention to the role of SMA employees in the unit, through remuneration for those who have been and will be participating in the business. It is necessary to have policies to support SMA employees in studying the specialized classes of reputable organizations or professional associations to apply the modern SMA, which is suitable for each type of business.

*Fourthly*, based on the results of the study, we see that Applying the SMA in manufacturing enterprises (HD) has a positive impact with the accomplishment (TQ).

### 5.1. Regarding the State and BAC Kan Province

The State and functional authorities need to soon issue preferential policies for the manufacturing enterprises to borrow investment capital in order to increase their access to credit capital by establishing a mechanism of enforcement



that is simple and clear to shorten the gap between policy and implementation. In addition, it is the creation of conditions through learning and exchanging with other businesses around the world to access and use the most advanced production technologies, technical machines and information technologies, especially, the policy of encouraging and supporting the enterprises to develop in the export market and sovereignty in the domestic market. The People's Committee of Bac Kan province and departments should soon have a separate policy of the province to help the enterprise with forestry production and mining to develop products that are the strengths of the province more and more. Facilitating policies to attract FDI capital to develop agricultural and forestry production in the area becomes effective in the coming years.

On the manufacturing enterprises' side, the businesses had initial interests in applying the SMA in the business. However, applying the SMA to be properly promoted to the benefits that it brings to the enterprise needs to perform the following tasks: (1) The decisions of the administrator are no longer formulated on the basis of path and experience that must change into fast strategy, from traditional business based on low cost to business based on innovation, in order to make better use of the economic advantages that each manufacturing enterprise has; (2) Administrators need to improve their management skills by themselves in order to adapt to the changing business environment today. At the same time, building plans for training employees in the enterprises so that all have an understanding of SMA.

## 6. References

- i. Abernethy, M.A. & J. Bouwens. (2005). *Determinants of accounting innovation*. Abacus, 41(3), 217-240
- ii. Aver, B., Aaver, B., & Cadez, S. (2009). Management accountants' participation in strategic management processes: a cross-industry comparison. *Journal for East European Management Studies*, 310-322.
- iii. Report No.:164/BC-SKHDT of Bac Kan Department of Planning and Investment dated 19/6/2020
- iv. Bromwich, M. (1990). The case for strategic management accounting: the role of accounting information for strategy in competitive markets. *Accounting, Organizations and Society*, 15(1-2), 27-46.
- v. Bromwich, M., & Bhimani, A. (1994). *Management Accounting: Pathways to Progress* (The Chartered Institute of Management Accountants).
- vi. Bui Thi Truc Quy (2020). *Factors affecting the application of strategic management accounting and its impacts on the operating accomplishment in the enterprises- study in the Southeast region of Vietnam*. Doctoral Thesis in Economics, University of Economics Ho Chi Minh.
- vii. Cadez, S., & Guilding, C. (2008). An exploratory investigation of an integrated contingency model of strategic management accounting. *Accounting, organizations and society*, 33(7-8), 836-863.
- viii. Cadez, S., & Guilding, C. (2008). An exploratory investigation of an integrated contingency model of strategic management accounting. *Accounting, organizations and society*, 33(7-8), 836-863.
- ix. Cameron, K. S. (1986). Effectiveness as paradox: Consensus and conflict in conceptions of organizational effectiveness. *Management science*, 32(5), 539-553.
- x. Chenhall, R. H. (2003). Management control systems design within its organizational context: findings from contingency-based research and directions for the future. *Accounting, organizations and society*, 28(2-3), 127-168.
- xi. Doan Ngoc Phi Anh (2012). *Factors affecting the application of strategic management accounting in Vietnam*. Journal of Economics Development, no. 264, 10/ 2012.
- xii. Emiaso, D., & Egbunike, A. P. (2018). Strategic management accounting practices and organizational performance of manufacturing firms in Nigeria. *Journal of Accounting and Financial Management*, 4(1), 10-18.
- xiii. Ezzamel, M. (1990). The impact of environmental uncertainty, managerial autonomy and size on budget characteristics. *Management Accounting Research*, 1(3), 181-197.
- xiv. Fisher, J. (1995). Contingency-based research on management control systems: Categorization by level of complexity. *Journal of Accounting Literature*, 14, 24-53.
- xv. Fowzia, R. (2011). Strategic management accounting techniques: Relationship with business strategy and strategic effectiveness of manufacturing organizations in Bangladesh. *World Journal of Management*, 3(2), 54-69.
- xvi. Galbraith, J. (1973). *Designing complex organizations*. Reading, MA: Addison-Wesley.
- xvii. Gordon, L. A., & Miller, D. (1976). A contingency framework for the design of accounting information systems. *In Readings in accounting for management control*, 569-585.
- xviii. Hair, J., Black, W. C., Babin, B. J., Anderson, R. E., & Tatham, R. (2010). *Multivariate data analysis* New Jersey: Pearson Education.
- xix. Hofstede, G. (1967). *The game of budget control-How to live with budgetary control and yet be motivated by them..* Assen: Van Gorcum & Comp.
- xx. Holloway, D. (2006). *Strategic management accounting and managerial decision-making reconceptualised: towards a collaboratively oriented theory of organizational decision enhancement (ODE)* (Doctoral dissertation, Murdoch University).
- xxi. Holloway, D. (2006). *Strategic management accounting and managerial decision-making reconceptualised: towards a collaboratively oriented theory of organizational decision enhancement (ODE)* (Doctoral dissertation, Murdoch University).
- xxii. Hwang, E. J. (2005). *Strategic management and financial performance in South Korean apparel retail stores* (Doctoral dissertation, Virginia Tech).
- xxiii. Kaplan, R. S. (1984). The evolution of management accounting. *In Readings in accounting for management control*, 586-621.

- xxiv. Mintzberg, H. (1987a). The strategy concept I: Five Ps for strategy. *California Management Review*, 30, 11-24
- xxv. Ngo Kim Thanh, 2012. Strategic management coursebook: Hong Duc Publishing House.
- xxvi. Nguyen Thi Thanh Loan (2016). Strategic management accounting with management control in the enterprises in Vietnam. *Journal of Science and Technology*, no. 34, 89-97.
- xxvii. Statistical yearbook in Bac Kan province (2019) in 2019
- xxviii. Noordin, R., Zainuddin, Y., Mail, R., & Sariman, N. K. (2015). Performance outcomes of strategic management accounting information usage in Malaysia: insights from electrical and electronics companies. *Procedia Economics and Finance*, 31, 13-25
- Oboh và Ajibolade (2017)
- xxix. Ojra, J. (2014). Strategic management accounting practices in Palestinian companies: application of contingency theory perspective (Doctoral dissertation, University of East Anglia).
- xxx. Ojra, J. (2014). Strategic management accounting practices in Palestinian companies: application of contingency theory perspective (Doctoral dissertation, University of East Anglia).
- xxxi. Ojua, M. O. (2016). Strategic management accounting practices among indigenous Nigerian manufacturing enterprises. *Open Science Journal*, 1(2), 1-13.
- xxxii. Otley, D. (1999). Performance management: a framework for management control systems research. *Management accounting research*, 10(4), 363-382.
- xxxiii. Thapayom, A. (2019). Strategic Management Accounting Techniques and Organizational Sustainable Performance: Evidence from Industrial Estates in Rayong Area, Thailand. *Journal of Modern Management Science*, 12(1), 51-74.
- xxxiv. Tillmann, K., & Goddard, A. (2008). Strategic management accounting and sense-making in a multinational company. *Management accounting research*, 19(1), 80-102.
- xxxv. Valančienė, L., & Gimžauskienė, E. (2007). Changing role of management accounting: Lithuanian Experience case studies. *Inžinerinė ekonomika*, (5), 16-23.