

Article

# The Effect of Emerging Green Market on Green Entrepreneurship and Sustainable Development in Knowledge-Based Companies

Maryam Lotfi <sup>1,\*</sup>, Akram Yousefi <sup>2</sup> and Soheil Jafari <sup>3</sup> 

<sup>1</sup> Cardiff Business School, Cardiff University, Cardiff CF10 1EU, UK

<sup>2</sup> Faculty of Management and Economics, Science and Research Branch, Islamic Azad University, Tehran 1477893855, Iran; akram.yousefi@srbiau.ac.ir

<sup>3</sup> Centre for Propulsion Engineering, School of Aerospace, Transport and Manufacturing (SATM), Cranfield University, Cranfield MK43 0AL, UK; S.Jafari@Cranfield.ac.uk

\* Correspondence: LotfiM@cardiff.ac.uk; Tel.: +44-292-251-0877

Received: 10 May 2018; Accepted: 2 July 2018; Published: 4 July 2018



**Abstract:** Environmental concerns, as well as consumers' awareness of buying green or environmentally-friendly products, has a positive impact on the emergence of the green market. The emerging green market brings many opportunities in different fields. Today, the issue of green entrepreneurship and sustainable development aim at producing environmentally-friendly products. This is indeed welcomed in the emerging green market. The publicly available research studies that investigate how green entrepreneurship, sustainable development, and emerging green markets are interconnected with each other are limited. More specifically, the impact of the green market on green entrepreneurship and sustainable development has not yet been studied completely. Therefore, a comprehensive research model has been developed in this paper based on the literature. The developed model is then tested using IBM SPSS Statistics for Windows, Version 19. IBM Corp.: Armonk, NY, USA and Smart-PLS Version 2 based on the data collected via a survey from a sample of knowledge-based companies in the Science & Technology Park of Tehran University. The results of the research indicate a positive and significant effect of the emergence of the green market on green entrepreneurship and sustainable development in knowledge-based companies. Moreover, the impact of the green entrepreneurship structure on sustainable development has been studied and the result presents that green entrepreneurship has a positive and significant effect on sustainable development.

**Keywords:** green market; green entrepreneurship; sustainable development

## 1. Introduction

In recent years, the environment has become a vital and crucial issue that affects all aspects of human life, leading to the emergence of the green market concept [1]. Therefore, issues related to environmental protection have become one of the first priorities in developing countries. In this regard, the need to produce ecological and environmentally-friendly products has forced companies to focus more on environmental issues in their businesses. The issue of the environment has made consumers to think about the products they are buying. Today, there is a great interest to protect the environment among consumers around the world; and the behavior of consumers is moving towards environmentally-friendly or green products [1]. The emergence of the green market has created a competitive advantage between responsible and non-responsible companies, in a way that has urged them to focus more on producing clean products. It seems that realizing this requires the emergence of entrepreneurs who discover and exploit the opportunities.

In fact, entrepreneurs introduce green products and technologies to the market and provide the ground for green entrepreneurship through the transformation of patterns and prototypes to tangible commercial products, and eventually green products and technologies are introduced to the market by green entrepreneurs. The existing structures in many modern societies are unstable, and achieving sustainable development requires a new way of thinking to change these structures, such as political, economic, social, and cultural systems. By shifting to the human view of nature, the concept of sustainable development is proposed in the field of interaction between the environment and business and their mutual effects on each other. Environmental issues are greatly emphasized by sustained development. In the process of the emergence of the green market, businesses need to pay equal attention to environmental and social purposes in contrast to their economic goals. Many researchers agree on green entrepreneurship as the driving force behind the emergence of a new economic growth with the advent of the green market. On the other hand, in order to illustrate the environmental problems created by various industries, the governments, private organizations and individuals have formulated a wide range of policy tools, standards, and instruments to encourage and facilitate businesses to comply with certain environmental considerations [2].

Lots of research has been done in the areas of green market, green entrepreneurship, and sustainable development. However, less research has looked at the three areas empirically to investigate the effect of emergence of the green market on green entrepreneurship and sustainable development. To fill this gap, the present study tries to answer the question of how the emergence of the green market affects green entrepreneurship and sustainable development. The article has seven sections. After the introduction, in Section 2, the theoretical background and research literature are presented. Specifically, literature have been reviewed for green market, sustainable development, and green entrepreneurship. Then, in Section 3, the research model and the related hypotheses are developed. In Section 4, the methodology has been discussed, specifically, the data collection sampling issues and questionnaire development steps are covered. The results are then presented in Section 5, and are discussed in Section 6. Finally, in Section 7, limitations of the research have been discussed and there are some avenues for future research.

## 2. Theoretical Background and Research Literature

### 2.1. Green Market

In recent years, a new scenario has come to study that is focused on the market tendency toward environment friendly products and services called “Green”. The main reason lying behind these changes is the increasing pressure on the human environment, including the spread of pollution and its harmful effects and consequences. Hence, consumer groups, business organizations, and governments have taken the issue seriously [1]. Increasing consumer awareness of environmental change has led them to change the form of products and services. With the emergence of green market, some new concepts emerged in the field of management, such as the green market, green supply chain management, and waste management. All these measures not only respond to the consumer’s need, but also guarantee a clean and green environment. Today, companies have to address environmental issues in their activities in order to meet the needs of their customers, commit to their social responsibility, and protect consumers’ rights, all of which entail the emergence of a new market called the green market. Factors, such as consumer awareness of the environment, that change consumer behavior towards buying green or environmentally-friendly products, as well as consumers’ perceptions of green products, have a positive impact on the emergence of the green market. ‘Green market’ in this research has been considered as a growing economic opportunity for green products, green design, green supply chain, and green production. The emerging green market is a market that brings many opportunities in a variety of fields, including green supply chain, green production, green design, and many more. The current market scenario creates many opportunities for entrepreneurs to empower and motivate green entrepreneurship [1].

## 2.2. Green Entrepreneurship

The concept of green entrepreneurship is a new issue that has attracted attention since the late 1990s and has grown steadily in recent years. Green entrepreneurship creates new products and technologies to solve environmental problems [3]. In its initial form, the term is derived from the combination of entrepreneurship and environment terms. However, many researchers believe that there is no comprehensive definition for it. Some others mention equivalents such as environmental entrepreneurs [4]. Green entrepreneurship is a new type of entrepreneurship, with commitment to environmental compatibility. It combines the passionate sense of business with the recognition of sustainability and other principles of the environmental movement in which compatibility with the environment must be specified and defined in any circumstances [5].

A green entrepreneur is an entrepreneur who aims to profit from green business. Green business refers to a product's nature, renewability, and intra-organizational green policies [6]. The green products and technologies are introduced to the market by "Green Entrepreneurs". They are the economic activists that realize green entrepreneurship through the transformation of patterns and prototypes into tangible business products.

The majority of policy mechanisms that make green growth possible are aimed at identifying technological innovations that reduce human impact on the environment and consider global environmental issues such as climate change. Green entrepreneurship is a growing phenomenon, but it still requires deeper investigation [7]. Green entrepreneurship is also a rapidly growing part of entrepreneurship that seeks to integrate environmental and social benefits of businesses in order to provide competitive advantages for companies.

Thus, it can be said that green entrepreneurship is a new type of entrepreneurship with a commitment to being environmentally friendly. Therefore, it can be stated that green entrepreneurship is no longer a mere business, but a kind of social activity that aims at protecting and preserving the natural environment.

## 2.3. Sustainable Development

Sustainable development, along with economic growth and human development, in a society is trying to obtain continuous development beyond economic development. Sustainable development is an organizing element that sustains non-renewable and limited resources with the aim to preserve them for the next generations. Sustainable development is a process that promises a desirable future for human societies, in which living conditions and use of resources will meet the human needs without damaging the integrity, beauty, and stability of vital systems [8]. Sustainable development means that achieving economic and social development is done in a way that does not exploit all the natural resources of a country, while maintaining and improving the quality of life of human beings who use the capacity of ecosystems around them. One of the goals of development, especially sustainable development, is to focus on environmental protection; therefore, sustainable development as a business challenge has always been at the forefront of policy-making over the past two decades [9]. Sustainable development provides solutions to structural, social, and economic mortal patterns of development to prevent problems such as the destruction of natural resources, the degradation of biological systems, pollution, climate change, the excessive population increase, injustice, and the deterioration of the quality of life both in the present and future. In conclusion, sustainable development is the process of using resources, directing investments, technology development, and institutional changes that are compatible with the needs of the present and future [10].

## 2.4. The Theoretical Framework of Research

An overview of the existing theoretical background, as well as the previous studies related to this research, provided the ground for presenting the framework of this study. Table 1 shows list of the most important references this study used to help to build its routes in green market, green entrepreneurship, and sustainable development.

**Table 1.** List of references this study used to help to build its routes in green market, green entrepreneurship, and sustainable development, and their contribution.

Reference	Scope	Findings
[11]	Entrepreneurship as a sustainable facilitator	Entrepreneurship has the ability to facilitate sustainable development by emphasizing on the evolution of the concept of production, exploitation, and innovation for the production of a new good or a new output, by reorganizing the industry and using technological facilities.
[12]	Consumer relationship with green marketing activities and their impact on consumers' purchase decision	The green character of the product has a positive effect on the buying behaviour of the majority of respondents. Improvement of the performance of Economic Cooperation Organization (ECO) countries has a positive impact on the behaviour of the majority of respondents.
[13]	The impact of green marketing on companies	Green innovation and green promotion have a positive effect on the performance of companies. With the rapid growth of green products around the world, marketers should be able to identify the best green markets and take appropriate strategies to cater for the needs and demands of consumers.
[14]	An evaluation of the role of green marketing and a firm's internal practices for environmental sustainability	Identification of four applied fields (i) green suppliers, (ii) environmental resource management, (iii) green research and development, and (iv) environmental manufacturing processes and procedures led the company to adopt a green marketing strategy.
[8]	Green marketing for sustainable development	Public and private companies are worried about the environment and believe that green marketing should become a norm in developing countries like India, and that green businesses and green marketing provide an opportunity to help sustainable development.
[1]	Emerging green market as an opportunity for green entrepreneurs and sustainable development in India	Consumers and the environment are more aware, and today, the concept of green products and the green market are taking place slowly and continuously in the market. This is a good opportunity for companies that believe in innovation and redesign their products and services in an economically successful way.
[15]	The effects of environmental focus and program timing on green marketing performance and the moderating role of resource commitment	Suggests that the commitment of proper resources is critical to the success of any green initiative. It also points out that being the first firm in an industry to start a green program provides few tangible benefits. More importantly, even firms with an environmental focus neglect to realize superior performance unless the specific strategy is matched with consistent top management support.
[16]	Sustainable entrepreneurship along green corridors	The green concept for transport and business has been introduced by the European Commission, which includes a framework for green entrepreneurship and sustainable development for the benefit of the ecosystem. The green concept of businesses has become overwhelming, therefore, a number of ways to provide a framework for sustainable development using the green concept of entrepreneurship are introduced.
[17]	Green entrepreneurship in transition economies	Entrepreneurs in transition economies do not seem to be ready to respond to the challenges of the transition or to any kind of risks associated with investing in the green business. In these countries, specific legislation is not seen as related to the green business framework, the promotion of green entrepreneurship, and the development of small businesses and small and medium enterprises.
[18]	Mixed marketing strategies to fill the gap between environmental beliefs of green consumers' confidence in beliefs	A significant gap exists between the pro-environmental beliefs and green consumer behaviour. The potential impact of consumer environmental concerns has been addressed. In general, there is a need for a broad expansion of applications and short-term marketing programs.

Table 1. Cont.

Reference	Scope	Findings
[19]	New topology for Green start-ups	Brings together research and theory on entrepreneurship and innovation, as well as sustainable business practice, and suggests a new topology to enable further empirical exploration of specific challenges and opportunities.
[20]	Towards new forms of sustainability governance in the food retailing	To analyze the role of retail eco-brands in the development of markets for sustainability certified food products.
[21]	Doing business in a green way	A systematic review of the ecological sustainability entrepreneurship literature and future research directions to help researchers to take stock of the existing literature and advance this research field.
[22]	Linking green market orientation and performance	To investigate how a competitive environment can motivate firms to adopt a green market orientation, and how that orientation can result in firms' superior performance (environmental and financial) through both internal green practice and green supply chain management.
[23]	A Co-Evolutionary Analysis of Sustainable Entrepreneurship, Innovation, and Transformation	To develop a theoretical framework to analyze co-evolutionary business model development for sustainable niche pioneers and conventional mass market players aiming at the sustainability transformation of markets.

Most of the previous studies have addressed the issue of green entrepreneurship and sustainable development separately. Besides, most studies have focused on the dimensions of green marketing, but none of the studies so far pointed at the emergence of the green market and its impact on sustainable development and green entrepreneurship. Therefore, by developing the following research model in Section 3, this research tries to fill this gap.

### 3. Research Model

#### *Conceptual Model and Hypotheses*

The literature review and the results of Sharma and Kushwaha [1] led us to develop a conceptual model. Factors, such as consumer awareness and the environment, that change consumer behavior towards purchasing green or environmentally friendly products, as well as consumers' perceptions of green product production, have a positive effect on the emergence of the green market. This market scenario creates many opportunities for entrepreneurship towards empowering and motivating green entrepreneurship [1]. Considering the humans' perspective toward nature, the concept of sustainable development in the field of interaction between the environment, business, and their mutual effect on each other can be pointed out. Therefore, it can be said that the emergence of the green market is an opportunity to achieve sustainable development [24].

At the same time, with the progress of the green market growth and development, opportunities emerge for entrepreneurs across the world. Innovations and the development of new products can emerge in the concept of green marketing. The entrepreneurs always focus their attention on innovative ideas. They hope that the community and market can help their businesses through them [1]. Hence, it can be said that companies that enter the term "green" in their marketing mix make a very wise and up-to-date decisions that will have a favorable outcome both now and in the future [25].

The change in consumers' pattern of purchase toward environmentally-friendly products and the environment, that is, green products, promises the creation of green entrepreneurship. Green entrepreneurs make innovation, replace traditional products by green products, and make an attempt to step in the green market following a gradual and continuous approach. The creation of the green market is an opportunity for entrepreneurs. Therefore, based on the definition presented by

Sharma & Kushwaha [1], the dimensions of the green market are made up of green product, green design, green supply chain, and green production. Hence, we formulate the following hypotheses:

The main Hypothesis  $H_1$ : The emergence of the green market has a positive impact on green entrepreneurship.

**Hypothesis 1-1 ( $H_{1-1}$ ):** Green product has a positive impact on green entrepreneurship.

**Hypothesis 1-2 ( $H_{1-2}$ ):** Green design has a positive impact on green entrepreneurship.

**Hypothesis 1-3 ( $H_{1-3}$ ):** Green supply chain has a positive impact on green entrepreneurship.

**Hypothesis 1-4 ( $H_{1-4}$ ):** Green production has a positive impact on green entrepreneurship.

As said, the concept of green business has been considered significantly, and methods have been developed to present a framework for sustainable development using the green concept within the scope of entrepreneurship [16]. Therefore, it can be said that the emergence of the green market is an opportunity to achieve sustainable development [24]. Green markets not only meet the consumers' needs, but also contribute to sustainable development in the long term [1]. Demand for ecological products and sustainable development activities has several reasons, including increasing level of customers' awareness about environmental issues [24]. The formation of environmental businesses and the green market represents an opportunity for contributing to sustainable development [8].

Hence, we formulate the following hypotheses:

The main Hypothesis  $H_2$ : The emergence of the green market has a positive impact on sustainable development.

Based on the results of Sharma and Kushwaha [1], the dimensions of the green market are made up of green product, green design, green supply chain, and green production. Hence, we formulate the following hypotheses:

**Hypothesis 2-1 ( $H_{2-1}$ ):** Green product has a positive impact on sustainable development.

**Hypothesis 2-2 ( $H_{2-2}$ ):** Green design has a positive impact on sustainable development.

**Hypothesis 2-3 ( $H_{2-3}$ ):** Green supply chain has a positive impact on sustainable development.

**Hypothesis 2-4 ( $H_{2-4}$ ):** Green production has a positive impact on sustainable development.

The full understanding of green entrepreneurship requires considering economic factors toward greening, which is because of the problems of natural resources and the environment, as well as how entrepreneurs can contribute to create a sustainable future. Green entrepreneurship has the ability to focus on the evolution of the concept of production, operation, and innovation for the production of a new product or a new output for products to be used to facilitate sustainable development through reorganization of the industry and the use of technological facilities [11]. Studies and research works indicate that green entrepreneurship plays outstanding roles in economic growth and development; presence in global markets; competitiveness; sustainable job-creation; justice promotion; national income; dissolution of the problems dealt by society, government, and the public sector; and realization of sustainable development [25]. Beyond any doubt, green entrepreneurship plays a key role in economic and sustainable development in any society. Entrepreneurship serves as a driving engine for economic development, without which no country may achieve economic development [26]. Hence, we formulate the following hypotheses:

The main Hypothesis  $H_3$ : Green entrepreneurship has a positive impact on sustainable development.

All hypotheses are shown in Figure 1 as the emergence of the green market.

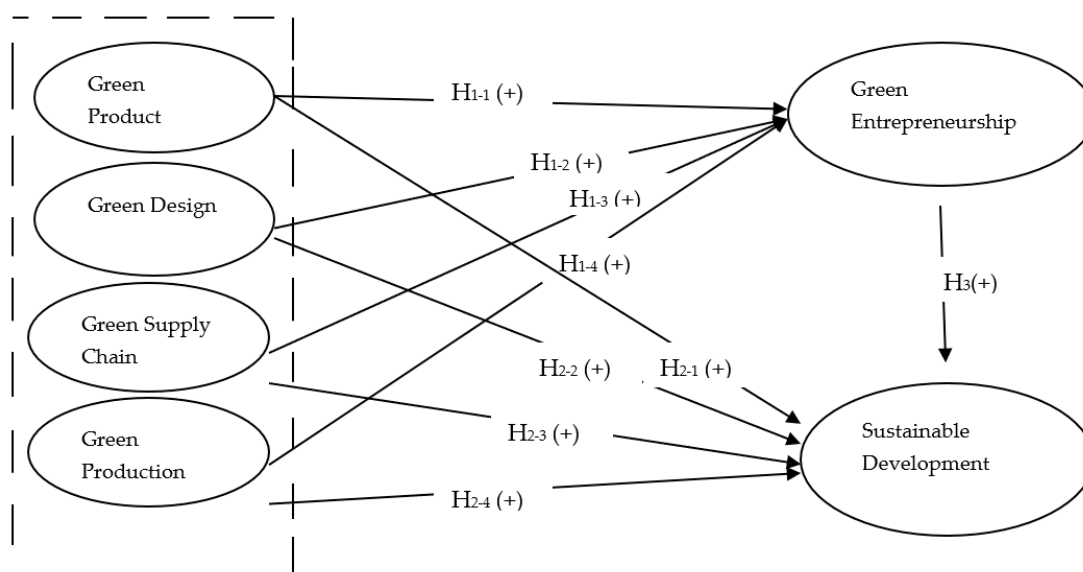

**Figure 1.** Research Theoretical Framework. (H<sub>1-1</sub>, H<sub>1-2</sub>, H<sub>1-2</sub>, H<sub>1-2</sub>, H<sub>1-2</sub>, H<sub>1-2</sub>, H<sub>1-2</sub>, H<sub>1-2</sub>, H<sub>1-2</sub>, are hypotheses of the model).

## 4. Methodology

### 4.1. Data Collection

To test the developed hypotheses, empirical data were collected using the questionnaire instrument.

The questionnaire used begins with a cover letter, followed by four parts (demographic items, items for evaluating green market as the independent variable, items for evaluating green entrepreneurship as a dependent variable, and items for evaluating sustainable development as a dependent variable).

Accordingly, the first part of the questionnaire was composed of five demographic questions: position of the respondent—general manager, technical manager, financial manager, sales manager, and so on; the manufacturing industry within which scope the company has its activities; number of employees of the company; average annual revenue; and manager's work experience. The second part included 20 questions for evaluating dimensions of green market (green product, green design, green production, and green supply chain). The third part of the questionnaire contained five questions for evaluating green entrepreneurship, and finally, the fourth part of the questionnaire was made up of five questions for examining sustainable development. The questionnaire is presented in Appendix A.

The questionnaire targeted all of the 150-knowledge based-companies in the Science and Technology Park of Tehran University. The survey was pilot tested with five managers and five academics from the university in which the main researchers were based at the time fame of the research. They were asked to review the questionnaire for readability, ambiguity, and completeness [27]. Then, minor changes were made based on these pre-tests.

The sample frame was the list of knowledge-based companies in the Science and Technology Park of Tehran University in Iran. All were delivered the questionnaire with the follow up of two weeks. Out of the 108 that were sent back, 85 were usable. Table 2 presents the sample characteristics.

**Table 2.** Sample characteristics (%).

<b>Title of Respondents:</b>		<b>No. of Employees:</b>	
General Manager	15.71	Less than 50	80
Technical Manager	15.71	50–150	17.1
Financial Manager	32.87	151–300	2.9
Sales Manager	11.44	More than 300	0
Others	24.27		
<b>Manufacturing industry:</b>		<b>Average annual sale:</b>	
Agriculture and natural resources	2.9	Less than \$5 Million	75.7
Information technology	21.4	\$5–15 Million	10
Advanced laboratory equipment	2.9	\$16–25 Million	1.4
Medical equipment	7.1	\$26–35 Million	1.4
Food and drug industries	4.3	Others	11.4
Mechanics and electronics	22.9		
Earth sciences	8.6	<b>Years of experience at the position:</b>	
Nanotechnology	2.9	Less than 1 years	1.4
Optics and photonics	2.9	Between 2 and 5 years	44.3
New energiese	2.9	Between 5 and 10 years	27.1
Others	21.4	More than 10 years	27.1

#### 4.2. Measures

Measures used in the survey were selected based on the extant literature reviewed. The criteria considered for designing the questionnaire for green market emergence construct included the following: green product, green design, green supply chain, and green production. All criteria of the questionnaire were evaluated and confirmed in terms of validity and reliability. All items were measured on Likert-type scales varying from 1 (strongly disagree) to 5 (strongly agree). Table 3 shows all constructs and their related measures.

**Table 3.** Constructs and their related measures.

<b>Construct</b>	<b>Measures</b>	<b>References</b>
Green product (GP)	GP1. It should contain elements that are useful for the environment.	[1,28,29]
	GP2. It should be efficient in terms of energy consumption.	
	GP3. It should be made from materials that make the product recyclable.	
	GP4. Its production process should be environmentally-friendly.	
	GP5. It should generate as low environmental pollution as possible.	
Green design (GD)	GD1. Product design should be performed according to environmental regulations.	[1,28,30]
	GD2. Product should be designed for lower adoption of hazardous raw material.	
	GD3. Product safety should be considered in the design process.	
	GD4. Products should be designed to minimize the consumption of sources of energy.	
	GD5. Product design should provide reusability.	
Green supply chain (GSC)	GSC1. The company should use ecologically effective transportation fleet.	[1,25,31]
	GSC2. Individuals should be promoted to adopt cost-effective driving to reduce fuel consumption.	
	GSC3. Environment management systems should be adopted according to up-to-date standards.	
	GSC4. Control and monitoring systems should be developed to ensure observance of environmental standards.	
	GSC5. Collaboration with green suppliers should be promoted.	



Table 3. Cont.

Construct	Measures	References
Green production (GP)	GP1. Product manufacturing should manifest environmental commitment of the company. GP2. One should adopt environmentally friendly technologies. GP3. Human health should be considered in the course of product manufacturing. GP4. Product manufacturing should be directed toward reduced environmental damages. GP5. Product manufacturing should be performed for green commerce.	[1,32,33]
Green Entrepreneurship (GE)	GE1. Green entrepreneurship eliminates environmental degradation. GE2. The company should establish a balance between raising profit, considering the environment, and taking into account innovation and modern methods for green business. GE3. Producing products and services for profitability and green commerce is a priority. GE4. Green businesses present opportunities for making profit from ecological scopes. GE5. Green entrepreneurship serves as a driving force for triggering new economic growth in modern economies.	[1,2,24,25]
Sustainable development (SD)	SD1. Increased human welfare may not be attained at the expense of interrupting ecologic processes. SD2. The company should prevent such problems as the degradation of natural resources. SD3. The company should prevent lowered quality of life for humans at present and future. SD4. The company should provide a basis for enhanced social and cultural positions of the societies. SD5. The company should proceed toward job by synergizing economic, social, and environmental factors.	[18,24,25]

## 5. Results

### 5.1. Measurement Model

Construct validity is verified by two criteria: (i) the measures of a construct should have the highest factor load on their construct [34] and (ii) the square average variance extraction (AVE) of a construct should be more than the correlation of that construct with other constructs, indicating that the correlation of that construct with its markers is more than its correlation with other constructs [35]. In Table 4, the sectional load of items on research constructs has been reported.

Table 4. Sectional factor loads for validity.

Question/ Variable	Green Product	Green Design	Green Supply Chain	Green Production	Green Entrepreneurship	Sustainable Development
GP1	0.73	0.12	0.28	0.11	0.29	0.26
GP2	0.65	0.53	0.32	0.3	0.34	0.22
GP3	0.68	0.17	0.3	0.1	0.29	0.27
GP4	0.88	0.49	0.5	0.35	0.51	0.47
GP5	0.84	0.51	0.45	0.44	0.46	0.54
GD1	0.43	0.78	0.27	0.31	0.4	0.39
GD2	0.38	0.57	0.17	0.26	0.15	0.28
GD3	0.32	0.75	0.42	0.22	0.39	0.19
GD4	0.34	0.85	0.38	0.38	0.35	0.37
GD5	0.14	0.67	0.33	0.29	0.29	0.31
GS1	0.31	0.38	0.8	0.3	0.51	0.33
GS2	0.39	0.35	0.84	0.19	0.49	0.29
GS3	0.45	0.45	0.78	0.39	0.46	0.43
GS4	0.35	0.28	0.79	0.43	0.5	0.39
GS5	0.5	0.26	0.74	0.41	0.43	0.48

Table 4. Cont.

Question/ Variable	Green Product	Green Design	Green Supply Chain	Green Production	Green Entrepreneurship	Sustainable Development
GP1	0.39	0.47	0.26	0.73	0.39	0.31
GP2	0.15	0.22	0.1	0.62	0.12	0.18
GP3	0.24	0.25	0.3	0.66	0.24	0.34
GP4	0.26	0.42	0.33	0.84	0.25	0.39
GP5	0.2	0.02	0.4	0.58	0.13	0.5
GE1	0.34	0.41	0.47	0.26	0.81	0.35
GE2	0.47	0.44	0.48	0.19	0.8	0.21
GE3	0.34	0.19	0.55	0.34	0.83	0.18
GE4	0.32	0.26	0.4	0.23	0.61	0.28
GE5	0.48	0.4	0.5	0.3	0.78	0.39
SD1	0.33	0.29	0.27	0.33	0.24	0.73
SD2	0.4	0.42	0.31	0.18	0.28	0.73
SD3	0.29	0.24	0.19	0.19	0.14	0.62
SD4	0.33	0.33	0.43	0.54	0.19	0.81
SD5	0.45	0.32	0.47	0.53	0.45	0.77

Discriminant validity was tested by comparing the correlation between the constructs and the square root of average variance extraction (AVE). To prove discriminant validity, all constructs should have an AVE larger than the correlation between any pair of them [35], as shown in Table 5.

Table 5. Correlation coefficient and the AVE square of each variable.

Variable	1	2	3	4	5	6
1. Green product	0.76					
2. Green design	0.41 **	0.73				
3. Green supply chain	0.53 **	0.43 **	0.79			
4. Green production	0.44 **	0.41 **	0.42 **	0.71		
5. Green entrepreneurship	0.50 **	0.51 **	0.60 **	0.41 **	0.77	
6. Sustainable Development	0.47 **	0.44 **	0.45 **	0.51 **	0.42 **	0.73

\*\*  $p < 0.01$ ; Note: the numbers on the diagonal of the correlation matrix are the mean of the extracted variance.

Reliability is measured by three criteria: (i) Cronbach's alpha, (ii) combined reliability (CR), and (iii) average variance extraction (AVE). Cronbach's alpha expresses the ability of measures to properly explain their construct. CR determines the correlation of measures of one construct to one another, which determines the adequate fitness of the measurement models [35]. In order to verify the reliability of constructs, the value of Cronbach's alpha and the reliability coefficient must be higher than 0.7, and the AVE should be above 0.5 [35]. The results of the reliability of the constructs criteria are shown in Table 6.

Table 6. The reliability of constructs.

Variable	PC	AVE	$\alpha$
Green product	0.87	0.58	0.82
Green design	0.85	0.53	0.77
Green supply chain	0.89	0.63	0.85
Green production	0.82	0.50	0.73
Green entrepreneurship	0.88	0.59	0.82
Sustainable development	0.85	0.54	0.70

## 5.2. Structural Model

To test the proposed conceptual model, partial least squares (PLS) (a structural equation modelling [SEM] technique) was used, which follows a two-step procedure (measurement model and structural model), suggested by Anderson and Gerbing [36]. PLS has been considered a good technique for small sample sizes [37].

Here, the impact of the emerging green market on green entrepreneurship and sustainable development was investigated. This was done by examining the path coefficients (factor loads) and  $R^2$  values with Smart-PLS version 2 [38]. Moreover, the strap method was used for calculating the T-value in order to determine the significance of path coefficients. Path coefficients are used to determine the contribution of each predictor variable in the explanation of the variance of the criterion variable. The values of  $R^2$  represent the criterion variable explained variance by predictive variables. The positive value of this coefficient represents the predictive ability [39]. When the t-value is related to a path in an interval greater than +1.96, it expresses the significance of the effect of certain constructs in that path on one another. Therefore, the main hypothesis of the research is confirmed [39]. Based on Figure 2, the t coefficient between the emerging green market construct and green entrepreneurship construct is 9.39. In addition, the t coefficient is 9.73 between the emerging green market construct and the sustainable development construct. Therefore, the main research hypotheses are accepted. Considering  $R^2$  values, 37% of the variance of green entrepreneurship and 38% of the variance of sustainable development are explained by the research model. According to the examined research model, the effects of emerging green market on green entrepreneurship and sustainable development are positive and significant.

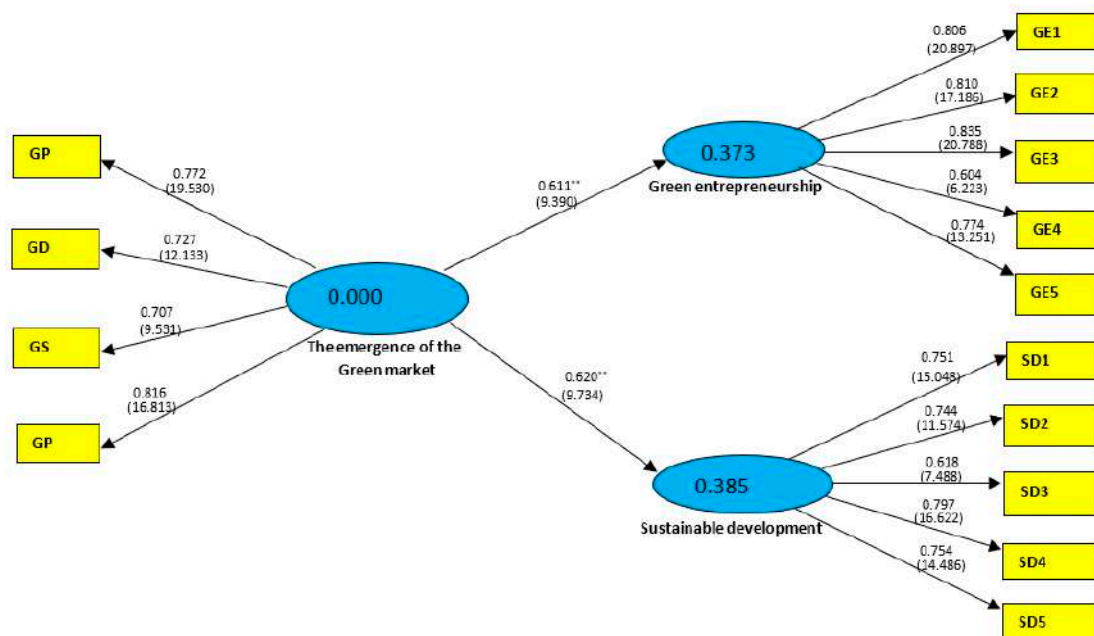

**Figure 2.** Structural model to check the main hypotheses. Note: \*\* indicates  $p < 0.01$ , Numbers in parentheses are t-values. GP—green production; GD—green design; GS—green supply chain; GE—green entrepreneurship; SD—sustainable development.

After confirming the main hypotheses, the sub-hypotheses of the research are examined. It was found that green product, green design, green supply chain, and green production have a positive and significant impact on green entrepreneurship and sustainable development. The output of the model contains standardized coefficients and t coefficients, as provided in Figure 3.

The t coefficients of all paths between the constructs are above +1.96, except for the green design on sustainable development path. Among the dimensions of the emerging green market, according to the standard path coefficient, the green supply chain (0.457) has the strongest impact on green entrepreneurship. Also, green product (0.230) has the strongest impact on sustainable development.

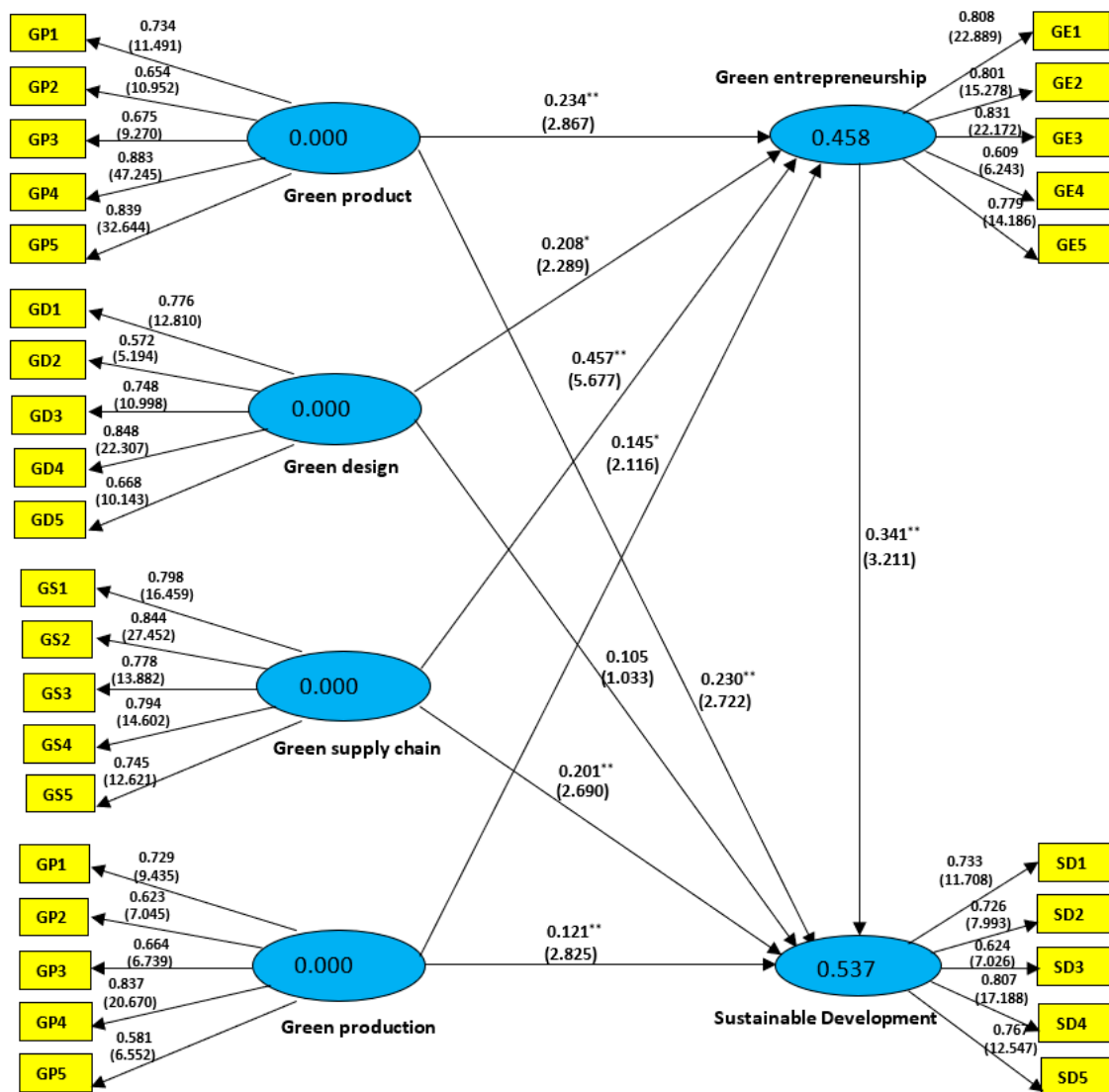

Figure 3. Structural model to check the sub-hypotheses. Note: \* indicates  $p < 0.05$ , \*\* indicates  $p < 0.01$ .

## 6. Discussion

### 6.1. Theoretical Implications

In this research, it was shown that the effects of the emerging green market on green entrepreneurship and sustainable development are positive and significant. In addition, the effects of green products, green design, green supply chain, and green production on green entrepreneurship and sustainable development were investigated. These effects were all positive and significant, except for the sixth sub-hypothesis that investigated the impact of green design on sustainable development.

Confirming the main hypotheses clarified that the emergence of the green market has a positive impact on sustainable development and green entrepreneurship. Paying attention to the emergence of the green market and the willingness of people to preserve the environment requires the existence of entrepreneurs who aim to maintain natural resources. In fact, entrepreneurs introduce green products and technologies to the market. Through the transformation of patterns and prototypes into tangible business products, green entrepreneurship can blossom. The existing structures in many contemporary societies are unstable. In addition, achieving sustainable development requires a new way of thinking to change these structures. These structures include the political, economic, social, and cultural

systems. By changing the human perception of nature, the concept of sustainable development in the terms of interaction between the environment and business and their mutual impact on each other are raised. Therefore, the results and findings of this study are consistent with what is conceptually pointed out by Sharma and Kushvaha [1]. The results of the research by the works of Hall et al. and Gast et al. [9,21] confirm that the green market should become a norm in countries. In addition, they concluded that considering environment green marketing in business is an opportunity to help sustainable development. These results provide support for the results of the present study.

The first sub-hypothesis refers to the impact of the green product on green entrepreneurship. To create a greener economy, there should be a range of new green products and technologies. By confirming the first sub-hypothesis, it can be argued that in order to have a green product, it is necessary to recognize the green opportunities. Besides, economic actors are needed as they play a vital role here, through the transformation of patterns and prototypes into concrete products, which leads to green entrepreneurship. Hence, the green product helps green entrepreneurship to flourish. This is consistent with the results of the studies by the works of [1,28], as well as D'Souza et al. [14].

The confirmation of the second sub-hypothesis makes it clear that the green design of the products has a positive and significant impact on green entrepreneurship. As mentioned, green design begins with planning and includes all materials and material selection, the production structure, the production process, the packaging, the shipping method, and the way in which the product is used. All of these processes create more opportunities in green entrepreneurship. The result of the present study is consistent with the results of the previous [1,28,40].

The third sub-hypothesis of research confirms the impact of green supply chain on green entrepreneurship. Supply chain needs to go green. The supply chains' journeys start with lean with the focus on cost reduction, then move to agile with the focus on being customer responsive, and then shift to resilient in order to be ready for all risks to encounter to them pass them, and to back to the original or even a better state [41]. This journey does not end in this point and now should move to the green and sustainable states. Going green means lots of opportunities for different actors in the supply chains, including manufacturers, suppliers, and retailers, finally leading to creating more opportunities for green entrepreneurship.

The confirmation of the fourth sub-hypothesis shows that green has a positive and significant effect on green entrepreneurship. Green production requires the presence of green entrepreneurs and green entrepreneurship, so that inputs with relatively low environmental impact and high efficiency, as well as less waste and pollution, become available in the production processes according to the works of [1,28].

The fifth sub-hypothesis confirmed that green products have a positive and significant impact on sustainable development. To create a greener economy, there should be a range of new green products and technologies. At the moment, in order to reduce the negative environmental and social impacts of production, instead of trying to improve products at the end point of the production line, the focus is on innovation in the field of clean products. Sustainable development also emphasizes these issues to preserve the environment for future generations [1,42].

The sixth sub hypothesis rejects the impact of green design on sustainable development. Scientists have shown that 80 percent of environmental impacts are affected by product design [38]. The application of green design can ensure companies that their products include recyclable and reusable components [16]. The reason could be that the statistical population of the present research (the knowledge-based companies based in Tehran University of the Science and Technology Park) is inherently more involved with more production or adding specific attributes to current product, rather than designing a product from the first stage. While previous studies, such as the works of [1,24,43], confirm the positive effect of green design on sustainable development, this study rejects this hypothesis. Therefore, more research in this area is suggested by the authors, specifically, exactly in the same context of knowledge-based companies.

The seventh sub-hypothesis confirms that the green supply chain has a positive and significant effect on sustainable development. Lotfi and Saghiri suggest that supply chains today try to be lean, agile, and resilient and that all of these approaches affect their performance in terms of cost, flexibility, recovery, and delivery [44]. Furthermore, Carvalho, suggest that the next step for supply chains is going to be green. A green supply chain is much more than simply reducing the consumption or pollution. Greening the supply chain includes the process of taking environmental measures across the supply chain. Green supply chain management integrates supply chain management with environmental requirements at all stages of supplying, manufacturing, and delivering the products to the customers. Thus, it can be said that green supply chain is consistent with sustainable development [1,25].

The confirmation of the eighth sub-hypothesis makes it clear that green production has a positive and significant effect on sustainable development. Green production is known as clean production. Adopting clean and advanced technologies will save energy and water. It will reduce pollutants and waste. Furthermore, recycling the raw materials in the production process can be achieved in pursuit of sustainable development goals based on the universal quality management principles by the works of [1,40].

The ninth sub-hypothesis indicated that green entrepreneurship has a positive and significant effect on sustainable development. A full understanding of green entrepreneurship requires taking economic movements towards greening because of the natural resources and environmental problems, as well as considering how entrepreneurs can contribute to creating a sustainable future. The environmental opportunities have led the entrepreneurial approach toward sustainable development, and drawn entrepreneurial activities in line with the environment. Moreover, entrepreneurship has the ability to emphasize transformation in the concept of production, operation, and innovation for the production of a new good output by using technological facilities to facilitate sustainable development [1,11]

## 6.2. Managerial and Practical Implication

Considering the significance of the impact of the emergence of the green market on green entrepreneurship and sustainable development, CEOs of knowledge-based companies can increase green entrepreneurship and sustainable development by creating and strengthening the green culture in their business. The CEOs acquire the knowledge necessary to set up green businesses and should attempt more in order to achieve greening the production and supply of products and services. This research shed light on this fact that green product, green design, green supply chain, and green production, as components of the emergence of the green market, can effectively help them to create more opportunities in green entrepreneurship sustainable development.

## 7. Limitations and Avenue for Future Research

This research has certain limitations that need to be mentioned here. While we aimed to obtain a sample representative of Iranian knowledge-based companies, the limited number of participants might constrain the generalization of the results. Similarly, because we mainly have one unique source of information, different points of view within the firms should be gathered in future studies. Finally, the conceptualization of the emerging green market, green entrepreneurship, and sustainable development should be further investigated. It is fair to point out that this work should be seen as the starting point in the field to look at these three concepts empirically. For future studies, other factors that affect green entrepreneurship and sustainable development can come into play. Specifically, the role of government in creating green businesses can be taken into account. In addition, the role of consumers in this model and the related implications need to be highlighted. In a fully democratic society, in which we are self-consciously influencing the flow of new products and services, consumers have most of the power. However, we are not there yet; companies still emphasize the introduction of their new products, and we try to be the first in line at the store that is carrying them. Therefore, it is highly suggested to investigate the direct effect of consumers on the emergence of the green market,

green entrepreneurship, and sustainable development. Finally, what are the economic and social benefits of sustainable development? What will motivate us to encourage sustainable development? From a capitalist perspective, what mostly wins, is what can earn the most money, which is often not the case when a product or service is perused that is actually sustainable. These are important concepts that need deeper investigation in future.

**Author Contributions:** M.L. developed the model. A.Y. and M.L. gathered the data. A.Y. and S.J. analyzed the model. A.Y. wrote the first version of the manuscript, heavily revised by M.L. All authors have read and approved the final manuscript.

**Funding:** The research received no external funding.

**Conflicts of Interest:** The authors declare no conflict of interests.

## Appendix A Questionnaire Items

### *About the Emerging Green Market*

#### Green Product (GP)

- GP1. It should contain elements that are useful for the environment.
- GP2. It should be efficient in terms of energy consumption.
- GP3. It should be made from materials that make the product recyclable.
- GP4. Its production process should be environmentally-friendly.
- GP5. It should generate as low environmental pollution as possible.

#### Green Design (GD)

- GD1. Product design should be performed according to environmental regulations.
- GD2. Product should be designed for lower adoption of hazardous raw material.
- GD3. Product safety should be considered in the design process.
- GD4. Products should be designed to minimize the consumption of sources of energy.
- GD5. Product design should provide reusability.

#### Green Supply Chain (GSC)

- GSC1. The company should use ecologically effective transportation fleet.
- GSC2. Individuals should be promoted to adopt cost-effective driving to reduce fuel consumption.
- GSC3. Environment management systems should be adopted according to up-to-date standards.
- GSC4. Control and monitoring systems should be developed to ensure observance of environmental standards.
- GSC5. Collaboration with green suppliers should be promoted.

#### Green Production (GP)

- GP1. Product manufacturing should manifest environmental commitment of the company.
- GP2. One should adopt environmentally-friendly technologies.
- GP3. Human health should be considered in the course of product manufacturing.
- GP4. Product manufacturing should be directed toward reduced environmental damages.
- GP5. Product manufacturing should be performed for green commerce.

#### Green Entrepreneurship (GE)

- GE1. Green entrepreneurship eliminates environmental degradation.
- GE2. The company should establish a balance between raising profit, considering the environment, and taking into account innovation and modern methods for green business.
- GE3. Producing products and services for profitability and green commerce is a priority.
- GE4. Green businesses present opportunities for making profit from ecological scopes.

GE5. Green entrepreneurship serves as a driving force for triggering new economic growth in modern economies.

#### Sustainable Development (SD)

SD1. Increased human welfare may not be attained at the expense of interrupting ecologic processes.

SD2. The company should prevent such problems as the degradation of natural resources.

SD3. The company should prevent lowered quality of life for present and future humans.

SD4. The company should provide a basis for enhanced social and cultural positions of the societies.

SD5. The company should give proceeds toward jobs by synergizing economic, social, and environmental factors; about the company and the owner.

#### Position of the respondent:

- General manager
- Technical manager
- Financial manager
- Sales manager
- Others

#### The manufacturing industry within which scope the company has its activities:

- Mechanics, electronics, control, and communication
- Information and telecommunication technologies and computer software
- Medical instruments, accessories, and equipment
- Nanotechnology and advanced material
- Optics and photonics
- High-tech manufacturing, production, and experimental equipment
- Renewable energies
- Food and pharmaceutical industries
- Agricultural science and natural resource
- Earth science
- Others

#### Number of employees of the company:

- Less than 50 individuals
- 51–150 individuals
- 151–300 individuals
- More than 300 individuals

#### Average annual revenue of the company:

- Less than \$5 million
- \$5–15 million
- \$16–25 million
- \$26–35 million
- Others

#### Work experience of the responding manager:

- Less than 1 year
- 2–5 years
- 5–10 years
- More than 10 years



## References

1. Sharma, N.K.; Kushwaha, G.S. Emerging Green market as an Opportunity for Green Entrepreneurship and Sustainable Development in India. *J. Entrep. Organ. Manag.* **2015**, *4*. [[CrossRef](#)]
2. Nikolaoua, E.I.; Ierapetritis, D.; Tsagarakis, K.P. An evaluation of the prospects of green entrepreneurship development using a SWOT analysis. *Int. J. Sustain. Dev. World Ecol.* **2011**, *18*, 1–16. [[CrossRef](#)]
3. York, J.G.; Venkataraman, S. The entrepreneur—Environment nexus: Uncertainty, innovation, and allocation. *J. Bus. Ventur.* **2010**, *25*, 449–463. [[CrossRef](#)]
4. Kirkwood, J.; Walton, S. How green is green? Ecopreneurs balancing environmental concerns and business goals. *J. Environ. Manag.* **2014**, *21*, 37–51. [[CrossRef](#)]
5. Arabiun, A.; Abdi, J.A.; Kashefi, A. Entrepreneurship in the context of modern technologies: An Approach to Green Entrepreneurship and Sustainable Development, Nanotechnology. In Proceedings of the First International Conference on the Environment and Natural Resources, Kharazmi Higher Education Institute of Science and Technology, Shiraz, Iran, 21 May 2015.
6. Walley, L.; Taylor, D.; Greig, K. Beynod the Visionary Champion: Testing a typology of green entrepreneurs. In *Making Ecopreneurs: Developing Sustainable*; Schaper, M.T., Ed.; Gower Publishing, Ltd.: Aldershot, UK, 2010.
7. Khanna, P. Assessment of heavy metal contamination in different vegetables grown in and around urban areas. *J. Environ. Toxicol.* **2011**, *5*, 162–179.
8. Garg, A. Green marketing for Sustainable Development: An Industry perspective. *J. Sustain. Dev.* **2015**, *23*, 301–316. [[CrossRef](#)]
9. Hall, J.K.; Leno, M.J. Sustainable development and entrepreneurship: Past contributions and future directions. *J. Bus. Ventur.* **2010**, *25*, 439–448. [[CrossRef](#)]
10. Kushwaha, R. *Green marketing: Opportunity for Innovation and Sustainable Development*; Jhunjhunwala Business School: Faizabad, India, 2010.
11. Horisch, J. Entrepreneurship as Facilitator for Sustainable Development? *J. Adv. Sustain. Entrep.* **2016**, *6*, 1–3.
12. Majerova, J. Analysis of Slovak Consumers perception of the green marketing Activitis. *Procedia Econ. Financ.* **2015**, *26*, 553–560. [[CrossRef](#)]
13. Hasan, Z.; Ali, N.A. The Impact of green marketing strategy on the firm's performance in Malaysia. *Procedia-Soc. Behav. Sci.* **2015**, *172*, 463–470. [[CrossRef](#)]
14. D'Souza, C.; Taghian, M.; Sullivan-Mort, G.; Gilmore, A. An Evaluation of the role of green marketing and a firm's internal practices for environmental sustainability. *J. Strateg. Mark.* **2015**, *23*, 600–615. [[CrossRef](#)]
15. Glenn, R.R.J.; Carolyn, F.; Musgrove, S.T.; Gillison, C.B.G. The effects of environmental focus and program timing on green marketing performance and the moderating role of resource commitment. *Ind. Mark. Manag.* **2014**, *43*, 1246–1257.
16. Prause, G.; Hunke, K. Suatainable Entrepreneurship Along green corridors. *Entrep. Sustain. Issues* **2014**, *1*, 114–133.
17. Silajdzic, I.; Midzic Kurtagic, S.; Vucijak, B. Green entrepreneurship in transition economies. *J. Clean. Prod.* **2015**, *88*, 376–384. [[CrossRef](#)]
18. Davari, A.; Strutton, D. Marketing mix Strategies for closing the gap between green consumers pro-environmental beliefs and behaviors. *J. Strateg. Mark.* **2014**, *22*, 563–586. [[CrossRef](#)]
19. Bergset, L.; Fichter, K. Green start-ups—A new typology for sustainable entrepreneurship and innovation research. *J. Innov. Manag.* **2015**, *3*, 118–144.
20. Chkanikova, O.; Lehner, M. Private eco-brands and green market development: towards new forms of sustainability governance in the food retailing. *J. Clean. Prod.* **2015**, *107*, 74–84. [[CrossRef](#)]
21. Gast, J.; Gundolf, K.; Cesinger, B. Doing business in a green way: A systematic review of the ecological sustainability entrepreneurship literature and future research directions. *J. Clean. Prod.* **2017**, *147*, 44–56. [[CrossRef](#)]
22. Li, Y.; Ye, F.; Sheu, C.; Yang, Q. Linking green market orientation and performance: Antecedents and processes. *J. Clean. Prod.* **2018**, *192*, 924–931. [[CrossRef](#)]
23. Schaltegger, S.; Lüdeke-Freund, F.; Erik, G. Hansen, Business Models for Sustainability: A Co-Evolutionary Analysis of Sustainable Entrepreneurship, Innovation, and Transformation. *Organ. Environ.* **2016**, *29*, 264–289. [[CrossRef](#)]

24. Emami, D. Networks and clusters of green entrepreneurship, Social, Economic, Scientific and Cultural Monthly. *J. Work Soc.* **2014**, *176*, 50–64.
25. Abdollahzadeh, G.; Sharifzadeh, M.S. Integration of Sustainability in the Process of Entrepreneurship: Explaining the Concept, Needs and Requirements of Sustainable Entrepreneurship and the Green Business. *J. Entrep. Agric.* **2014**, *1*, 39–62.
26. Schumpeter, J.A. *Theory of Economic Development*; Harvard University Press: Cambridge, MA, USA, 1934.
27. Dillman, D.A. The design and administration of mail surveys. *Annu. Rev. Sociol.* **1991**, *1*, 225–249. [[CrossRef](#)]
28. Ranaei Kordshuli, H.; Yari, A. The Effect of Green Marketing Mix on Green Shopping Decision of Consumers. *Res.-Sci. J. Mod. Mark.* **2012**, *4*, 92–165.
29. Borin, N.; Douglas, C.; Cerf, K.R. Consumer effects of environmental impact in product labeling. *J. Consum. Mark.* **2011**, *28*, 76–86. [[CrossRef](#)]
30. Hanington, P.C.; Rieger, A.M.; Belosevic, M.; Konowalchuk, J.D.; Havixbeck, J.J.; Smith, M.K.; Robbins, J.S.; Lund, J.M. A teleost CSF-1 receptor is a novel regulator of macrophage proliferation and inflammation. *Fish Shellfish Immunol.* **2013**, *6*, 1638.
31. Duber-Smith, D.C. The Imperative Soap. *Perfum. Cosmet.* **2012**, *78*, 24–26.
32. Ninlawan, C.; Seksan, P.; Tossapol, K. The Implementation of Green Supply Chain Management Practices in Electronics Industry. In *Proceeding of the International Multi Conference of Engineering and Computer Scientists*, Hong Kong, 17–19 March 2010.
33. Lixiongyi Wang, W. *Research on Green Supply Chain Management*; School of Management Zhongyuan University of Technology: Zhongyuan, China, 2011; pp. 45–47.
34. Gefen, D.; Straub, D.W. A practical guide to factorial validity using PLS-Graph: Tutorial and annotated example. *Commun. AIS* **2005**, *16*, 91–109.
35. Fornell, C.; Larcker, D.F. Evaluating structural equations models with unobservable variables and measurement error. *J. Mark. Res.* **1981**, *18*, 39–50. [[CrossRef](#)]
36. Anderson, J.C.; Gerbing, D.W. Some methods for re-specifying measurement models to obtain unidimensional construct measurement. *J. Mark. Res.* **1988**, *19*, 453–460. [[CrossRef](#)]
37. Barclay, D.W.; Higgins, C.; Thompson, R. The partial least squares (PLS) approach to causal modeling: Personal computer adaptation and use as an illustration. *Technol. Stud.* **1995**, *2*, 285–309.
38. Seyed Abaszadeh, M.M.; Amani Sari Begloo, J.; Hayman Khezri, A.; Pashavi, G. *An Introduction to the Structural Equation Model Using PLS Method and Its Application in Behavioral Sciences*; Urumia University Press: Urumia, Iran, 2012.
39. Vinzi, V.E.; Trinchera, L.; Amato, S. PLS path modeling: From foundations to recent developments and open issues for model assessment and improvement. In *Handbook of Partial Least Squares*; Springer: Berlin, Germany, 2010; pp. 47–82.
40. Mohammadian, M. The importance of green marketing in the field of entrepreneurship and the identification and ranking of the most important executive challenges. In *Proceedings of the National Conference on Entrepreneurship in the Knowledge-Based Industry*, Tehran, Iran, 3–5 June 2013.
41. Lotfi, M. *Resilience, Agility, and Leanness in Supply Chain Management*; Conceptual Development and Empirical Analysis; Scholars' Press: Saarbrücken, Germany, 2018.
42. Mousavi, S.F. Identification of Effective Factors on Green Marketing and Its Consequences. In *Proceedings of the Second National Conference on Modern Management Science*, Tehran, Iran, 25–27 July 2013.
43. Gulcin, B.; Gizem, C. Evaluation of the green supply chain management practices: A fuzzy ANP approach. *Prod. Plan. Control Manag. Oper.* **2012**, *23*, 405–418.
44. Lotfi, M.; Saghiri, S. Disentangling resilience, agility and leanness: Conceptual development and empirical analysis. *J. Manuf. Technol. Manag.* **2018**, *29*, 168–197. [[CrossRef](#)]

