

Article

The Moderating Effects of Corporate Social Responsibility on the Relationship between Creative Accounting Determinants and Financial Reporting Quality

Ibtihal A. Abed¹, Nazimah Hussin¹, Hossam Haddad², Nidal Mahmoud Al-Ramahi³ and Mostafa A. Ali^{1,*} 

¹ Azman Hashim International Business School, Universiti Teknologi Malaysia, Kuala Lumpur 54100, Malaysia; ahmed-1988@graduate.utm.my (I.A.A.); nazimah.kl@utm.my (N.H.)

² Business Faculty, Middle East University, Amman 11831, Jordan; Hhaddad@meu.edu.jo

³ Business Faculty, Zarqa University, Zarqa 11831, Jordan; Ramahinedal@zu.edu.jo

* Correspondence: mostafa1988@graduate.utm.my

Abstract: The banking sector is reflected as an essential element in the structure of any economy that leads to the growth of financial capacity for various individuals, organizations, businesses, and countries worldwide. Accounting activities are shown in the financial reports of banks, while the relevant literature has found that creative accounting highly impacts the quality of financial reporting. However, previous studies indicated the limited impacts of creative accounting determinants on the quality of financial reporting, whereas the phenomenon of financial reporting quality is still on the track of generating renewed research interests. The present research investigated the implications of corporate social responsibility on enhancing the impacts of the determinants of creative accounting and the quality of financial reporting in the context of commercial banks. A deductive research approach driven by a survey questionnaire was used as the research methodology to attain the objectives. Accordingly, purposive sampling was used to collect responses from 364 employees of Iraqi commercial banks (with a response rate of 72.8%). The data were analyzed statistically using the SPSS v.25 and AMOS v.24 software. The results show significant impacts of corporate social responsibility in moderating the relationship between the determinants of creative accounting and financial reporting quality of banks towards competitive advantages.

Keywords: ethical issues; disclosure quality; internal control; ownership structure; financial reporting; information asymmetry; banking sector



Citation: Abed, I.A.; Hussin, N.; Haddad, H.; Al-Ramahi, N.M.; Ali, M.A. The Moderating Effects of Corporate Social Responsibility on the Relationship between Creative Accounting Determinants and Financial Reporting Quality. *Sustainability* **2022**, *14*, 1195. <https://doi.org/10.3390/su14031195>

Academic Editors:
Jennifer Martínez-Ferrero
and Bruce Morley

Received: 26 November 2021

Accepted: 12 January 2022

Published: 21 January 2022

Publisher's Note: MDPI stays neutral with regard to jurisdictional claims in published maps and institutional affiliations.



Copyright: © 2022 by the authors. Licensee MDPI, Basel, Switzerland. This article is an open access article distributed under the terms and conditions of the Creative Commons Attribution (CC BY) license (<https://creativecommons.org/licenses/by/4.0/>).

1. Introduction

This study investigates the association between creative accounting determinants and financial reporting quality and addresses the debate on the implications for sustainable business strategies. Stakeholders' pressures and information demands have changed significantly in recent years, and companies are required to respond [1]. Sustainability reporting is an important communication tool for demonstrating transparency and effective governance and is specifically addressed to stakeholders [2]. The need to provide transparency to stakeholders is a driver of enhanced reporting quality [3]. In addition, a few studies have focused on sustainability information disclosure to capture disclosure information standardization levels based on international indicators [4].

Financial reporting features agreements with providing reliable, accurate, and timely financial data required by stakeholders for making decisions concerning banks' operations [5]. The objective of financial reporting is to present financial data to users in order to facilitate informed and objective decisions. Nevertheless, the present accounting policy provides some choice concerning accounting techniques and the use of objective judgement to define measurement policies, recognition criteria, and, in some cases, the characterization

of the accounting body. The ability to choose several aspects of accounting allows for deliberate information manipulation or concealment. Such manipulations increase businesses' apparent attractiveness that can project better profitability and financial stability instead of the actual position [6]. Thus, the financial reports of banks can provide a direction of reliance to users towards objective decision making [7]. Essentially, the reports used for financial decision making must be understandable, comparable, relevant, and realistic.

The body of knowledge concerning creative accounting does not explicitly specify if the auditor is obliged to unmask aspects of creative accounting that are permitted and legal. Hence, the intention is to assess the use of creative accounting in Iraq and its effects on the banking sector and its financial reporting quality. It should be noted that auditing standards require that auditors formulate processes that can ascertain if the accounting practice followed by a business entity can record financial information correctly. The auditors are only obliged to ensure that a business's financial information presents an accurate and fair state of the company's financial position [8,9]. There is no explicit obligation for assessing and discovering fraud. The significance of specific research on corporate social responsibility and its association with creative accounting and all its manifestations concerns the overall trend that inadequate governance provides or sustains an impetus to manipulative activities [10]. Poor corporate social responsibility has a higher correlation with accounting manipulation [11–13].

This study aimed to understand both empirical and theoretical viewpoints in this domain by formulating a structure that provides hands-on support for regulators and investors related to the banking industry. This study provides a fresh perspective concerning creative accounting and contributes significantly to the related literature because creative accounting in Iraq has not been studied extensively. The endeavor is to enrich the literature concerning creative accounting. There are three aspects: Firstly, we intended to assess the primary determinants of creative accounting such as ethical issues, internal control, disclosure quality, and ownership structure. Secondly, this study evaluated the effectiveness of strong corporate social responsibility concerning eradicating creative accounting by the banking sector in Iraq. Thirdly, we intended to use information concerning commercial banks in Iraq to determine the degree to which creative accounting is entrenched in Iraq's banking system. Lastly, the present research assessed financial reporting quality as a practice in commercial banks in Iraq from the perspective of regulatory agencies, corporate social responsibility, and other aspects. However, there is limited evidence on how the impact of determinants of creative accounting on financial reporting quality is affected by corporate social responsibility in the banking sector of Iraq. This study aimed to examine the joint influence of determinants of creative accounting and corporate social responsibility on financial reporting quality in Iraq. It concentrated on two questions:

1. What are the effects of creative accounting determinants on financial reporting quality in the banking sector?
2. To what extent does corporate social responsibility moderate the relationship between creative accounting and financial reporting quality?

Finally, the findings of this study will be useful to policymakers, researchers, and managers. In particular, they provide current knowledge of the effect of corporate social responsibility, creative accounting, and financial reporting quality, contributing to the literature on performance and the firm-based view. Thus, the present research was designed to attain the following objectives that contribute to limiting the practice of creative accounting and increasing the quality of financial reports in the banking sector:

1. To identify the effects of creative accounting determinants on financial reporting quality in the banking sector;
2. To examine the moderating effects of corporate social responsibility on the relationship between creative accounting determinants and financial reporting quality.

2. Theoretical Background

2.1. Creative Accounting and Financial Reporting Quality

Creative accounting practices do not often break the law, nor are they considered illegal; however, accounting managers may exploit the ambiguities in the law for portraying the financial standing of the firm, according to the preferences specified by the management [14]. These practices help them overestimate the economic and financial conditions of the firm, which leads to poor accounting and financial reporting. Organizations present their annual financial results to the public, which describe all data related to their financial position, cash flow, and company performance. Earlier studies have stated that these data are very useful to many users, i.e., private and public users, while making economic decisions [15]. For instance, financial statements can affect the election of the bank owner [16]. Earlier studies showed that creative accounting practices affected the financial reporting quality [17–20]. However, none of the earlier studies defined a clear determinant for assessing these practices. In this study, the researchers attempted to define some determinants which can affect the financial reporting quality. This study can also explain the various manipulative practices which are implemented during the presentation of financial reports and their effect on the banking industry.

The literature argues that the tendency of some managers to focus on short-term gains is mainly responsible for unethical environments in firms, which further encourages poor financial reporting [10]. It was noted that when managers adopt ethical behavior, the accounting transparency in the firm can increase [21]. Some studies examined the acceptability and implementation of ethical behavior amongst accountants, treasurers, and institutional investors [22]. They observed that the treasurers significantly implemented creative accounting practices, whereas regulators and public accountants rarely carried out creative accounting practices. They also noted that the attitude of the managers was primarily responsible for creative accounting. Their attitude indicated that the quality of financial reporting was significantly affected by the ethical behavior of the managers [23,24]. Other researchers proposed a direct approach that suggested that managerial and corporate ethics affect the quality of financial reporting [25]. Thus, it can be concluded that an ethical environment and ethical management affect the quality of financial reporting. Firms having a good track record present high-quality financial report.

A direct relationship has been noted between the degree of creative accounting practices and information asymmetry, wherein an increase in creative accounting practices indicates an increase in information asymmetry. Hence, information asymmetry present between the investors and management is vital for creative accounting practices [26]. Improved disclosure quality in an organization leads to a decrease in information asymmetry. This decrease in the information asymmetry of the management is related to low earnings. Hence, a negative association is noted between creative accounting practices and disclosure quality [27]. Companies with a lower disclosure quality and higher creative accounting, in the long term, acquire a stock that is priced below its value. This highlights a direct relationship between disclosure quality, creative accounting, and firm value [28]. Thus, after reviewing many papers, the researchers noted a positive relationship between disclosure quality and financial reporting quality. Studies have highlighted a positive relationship between the financial reporting quality and the amount of information which is disclosed by the management. This type of positive relationship hindered the managerial earning manipulation and unethical opportunistic financial reporting behavior carried out by the firm's management in one study [29].

Thus, any failure to detect or prevent fraud or wrong statements in financial reporting can negatively affect the reporting quality. Thus, agency theory states that internal control of financial reporting is overlooked and aligns interests between the agent and principal [30]. Furthermore, inefficient internal control of the financial reporting of a company can affect its financial reporting quality. However, efficient internal control of the financial reporting reflects the commitment of the organization to disclose all vital information to the public and their shareholders [31]. Consequently, it is noted that internal control of financial reporting

can improve the quality of financial reporting. Several researchers have mentioned that internal control of financial reporting can affect any improvements that are carried out in the financial reporting quality [32–34].

The correlation between the financial reporting quality and ownership structure has been studied in many types of research. However, previous research has only specified the characteristics of equity shareholders and their shareholding capacity in any bank where the ownership structure depends on how the bank's shares are distributed with regard to voting rights and paid capital. This indicates shareholders have a lesser incentive to manipulate financial statements, thereby decreasing creative accounting practices. Similar observations were reported by a few earlier studies [11,19,35], which concluded that a negative correlation exists between creative accounting and the ownership structure. They also noted that the ownership structure improved the financial reporting quality by decreasing the level of creative accounting practices. However, not all earlier studies followed this theory. It has been observed that when the ownership structure carried out weak supervision of the organization's employees, the financial reporting quality was increased [36], and a significant effect of the ownership structure on creative accounting and financial reporting quality has been detected [37]. The ownership structure allows the employees to develop a sense of belonging towards their organization. As a result, the owners and agents do not face any conflict of interest [38]. Based on these results, the following hypotheses could be formulated:

Hypothesis H1a (H1a). *A Low consideration of ethical issues results in a low level of financial reporting quality.*

Hypothesis H1b (H1b). *A low level of disclosure quality indicates a low level of financial reporting quality.*

Hypothesis H1c (H1c). *A low level of internal control indicates a low level of financial reporting quality.*

Hypothesis H1d (H1d). *A low level of ownership structure indicates a low level of financial reporting quality.*

2.2. The Moderating Effect of Corporate Social Responsibility

In recent years, many researchers have realized the significance of the relationship between corporate social responsibility and financial reporting quality [5,9]. The focus on corporate social responsibility does not represent cost–benefit analysis, since the firms which primarily focus on corporate social responsibility limit the role played by creative accounting [39]. Firms need to conduct analysis which offers additional benefits and can impact their financial reporting quality. Corporate social responsibility decreases the issues faced by an agency [40]. Corporate social responsibility is used by firms who aim to fulfil their moral and social needs, and it can prevent any conflict of interest between the shareholders, stakeholders, and managers [41].

Moreover, managers often implement corporate social responsibility as an incentive for hiding their creative accounting practices and avoiding the cost of being fined for their lower financial reporting quality [42]. However, many earlier studies showed that corporate social responsibility practices were positively associated with the ethical behavior of managers. It was observed that the moral development of managers was related to their corporate social responsibility engagement [39]. This supported the idea that corporate social responsibility practices act as ethical incentives for managers who desire to serve their society. If corporate social responsibility practices are related to the intentions of managers to hide their shady creative accounting practices, this cost should be lower than the cost of punishment for their poor-quality financial reporting [20].

Very few earlier studies have investigated the moderating role played by corporate social responsibility on the relationship between disclosure quality and financial reporting

quality. One piece of evidence showed that when the firm's corporate social responsibility disclosure strengthened, the positive market value of its responsibility decreased [43]. Similarly, when the firm's corporate social responsibility disclosure strengthened, the negative market value of its corporate social responsibility was concerning. Disclosure quality improved one firm's financial reporting quality [28], whereas the publication of an integrated corporate report positively moderated the relationship between the disclosure quality and financial reporting quality [44].

The internal control quality affects the quality of financial reporting [45]. In the corporate social responsibility process, the allocation of rights, responsibilities, and interests must not be conventionally limited; however, it needs to reflect corporate social responsibility practices. Internal control is associated with the fulfilment of corporate social responsibility practices [46]. The internal control process needs to ensure that firms are carrying out their corporate social responsibility practices and thereby maintaining the interests and legitimate rights of the stakeholders [47]. Hence, the increased effectiveness of corporate social responsibility practices in firms increases their level of internal control practices, which improves the financial reporting quality.

It has been noted that shareholders, founders, and managers generally tend to initiate some traditions in their organizations for implementing corporate social responsibility practices and avoid other harmful practices which can negatively affect the organization's image [36]. All these practices are based on their desire to improve or maintain their financial reporting quality. Furthermore, since stakeholders strongly identify with organizations, the ownership structure fears that a decrease in its corporate reputation can tarnish the organization's name [48,49]. Several researchers have stated that the ownership structure can significantly influence financial reporting quality [50]. The ownership structure influenced the financial reporting quality as it exercised voting power and possessed an asymmetric information advantage compared to other shareholders [51]. Based on the above logic, we proposed the following interaction hypotheses:

Hypothesis H2a (H2a). *Corporate social responsibility positively moderates the relationship between ethical issues and financial reporting quality.*

Hypothesis H2b (H2b). *Corporate social responsibility positively moderates the relationship between disclosure quality and financial reporting quality.*

Hypothesis H2c (H2c). *Corporate social responsibility positively moderates the relationship between internal control and financial reporting quality.*

Hypothesis H2d (H2d). *Corporate social responsibility positively moderates the relationship between ownership structure and financial reporting quality.*

The theoretical framework of the current study contains one independent variable, 'creative accounting determinants', one moderating variable, 'corporate social responsibility', and one dependent variable, 'financial reporting quality', as shown in Figure 1.

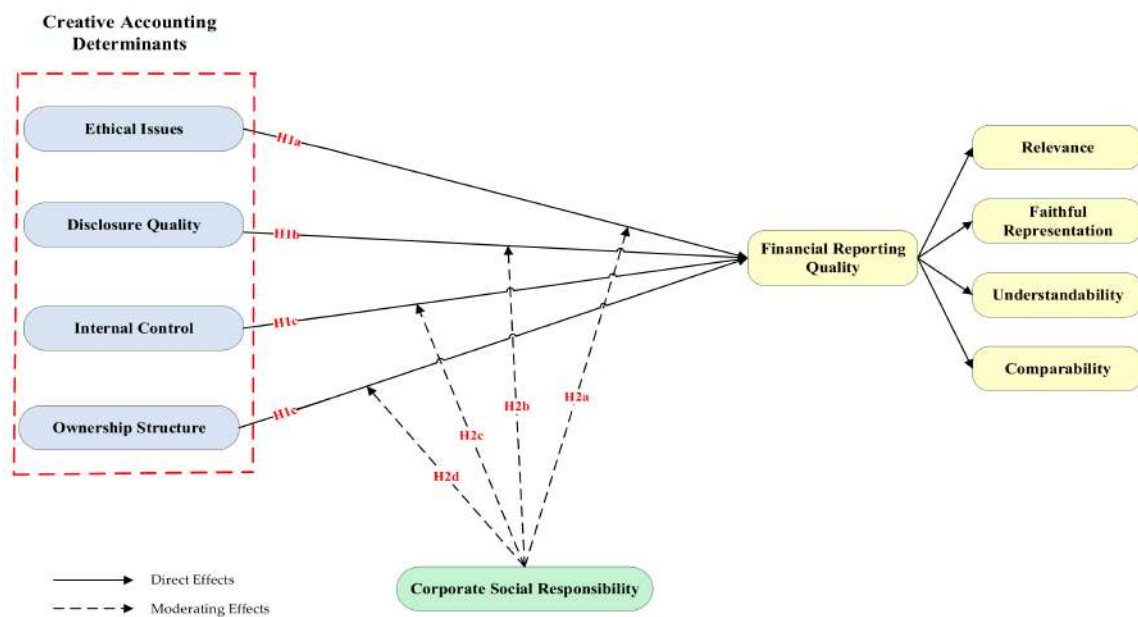

Figure 1. Conceptual framework of the present study.

3. Research Method

3.1. Study Population

The present research population encompassed twenty-four Iraqi commercial banks in the year 2020. The main reasons for selecting this type of bank out of the financial population were the flexibility and accessibility of commercial banks. It is worth mentioning that the user friendliness and flexible nature of these cited banks allowed the researchers to select them as the primary financial population. In addition, Iraqi commercial banks view such flexible attributes as their visibility to external auditors. Furthermore, the accessibility of and collection of data through the proper approval process from other banks in Iraq were complicated, which was the main reason for choosing Iraqi commercial banks as the target population in this research.

3.2. Sampling Size

The ever-growing demand for research has given rise to the necessity for an effective technique for defining the required sample size in a given population. The previous literature declared that no additional calculations are required to identify the sample size in quantitative research [52]. A standard table has been developed for calculating the sizes of samples required for studies. The current study aimed to investigate a population of 7000 employees from twenty-four commercial banks. Thus, a sample size of 364 participants was required to investigate the current phenomena. As such, a total of 500 questionnaires were distributed to employees in banks. This took into consideration that the larger the study sample, the more the results can be generalized to the target population. The selected sampling method enabled the gathering of accurate information from the population concerning creative accounting, financial reporting quality, and corporate social responsibility.

3.3. Sampling Technique

Purposive sampling of the estimated population was more suitable for the present research. Bank accountants who are experienced and familiar with the preparation of financial reports are expected to possess and reflect expert knowledge, and they provide relevant data for research inquires. Thus, the respondents for the present research were bank accountants who were involved in banking business, regardless of their rank or job position. Hence, we chose an individual-level analysis for the present study in order to evaluate the correlation between creative accounting, financial reporting quality, and

corporate social responsibility. Furthermore, the respondents used for the study comprise accountants serving in commercial banks. The selection of accountants was a planned decision: accountants are involved the most with the research context. Therefore, they possess a strong understanding of the support required by firms for ‘value creation’. These reasons established the researchers’ position to measure variables and forecast the correlation between the specified variables precisely.

3.4. Data Collection Procedures

The study questionnaire was prepared, considering the primary objective, and customised for specific fundamental aspects. Questionnaires permit rapid data collection [53] and immediate questioning of respondents’ doubts [54]. Data collection began on 10 September 2020 and was concluded on 10 December 2020, which is roughly three months. Bank branches are scattered across different areas in Iraq; hence, a significant amount of time was allocated for data collection. The banks were informed before the research team’s arrival for questionnaire distribution. The data collection process was indicated in advance. Some banks also required permission from the authorities through in-person or email-based approval before they could disclose data. This process consisted of bank managers seeking permission to communicate with respondents individually. After permission was obtained, respondents were informed about the research and were provided ample time to answer all questions. In case respondents faced challenges, they were assisted so that they understood the context precisely. It was required for respondents to answer the survey and hand over the responses directly to enhance the response rate. Data collection ended with the researchers obtaining 392 responses.

3.5. Response Rate

To achieve the appropriate response rate, 500 questionnaires were distributed to employees in selected commercial banks in Iraq. Out of the 392 questionnaires that were returned to the researchers, 28 questionnaires were excluded as they had incomplete responses or missing data. This is a safe and easy method that is most commonly used in any statistical study to avoid bias due to incomplete questionnaires and cases of missing data. Thus, 364 responses were used for the analysis. The distribution of the questionnaires and the response rate are shown in Table 1.

Table 1. The response rate of the data collected.

Description	No. of Questionnaires	Percentage
Total questionnaires that were distributed	500	100%
Received completed questionnaires	392	78.4%
Uncompleted or had missing data	28	7.1%
Usable questionnaires	364	92.9%

3.6. Measures

Creative accounting: Determinants of creative accounting were developed based on various studies, such as five items to measure ethical issues that were adapted from [55]. Another five items were adapted from [56] to measure the disclosure quality. Internal control adapted five items from [57]. Ownership structure adapted five items from [58]. Corporate social responsibility: the five items that measured corporate social responsibility were mainly based on five items adapted from [3]. Financial reporting quality: this study measured financial reporting quality using 20 items based on the research of [59]. (See Appendix A) Responses were recorded on a 5-point scale ranging from 1, strongly disagree, to 5, strongly agree.

3.7. Analysis and Results

There were two main stages to the data analysis. The first stage was conducted using SPSS.v²⁵ to provide information about the data distribution, response rate, multicollinearity,

and coding. This was followed by the screening of the data to ensure there were no missing data and outliers. The second stage of the data analysis in the current study was conducted in two phases using AMOS.v²⁴. The first phase was a confirmatory factor analysis (CFA) to assess the overall measurement model, while the second phase involved structural equation modeling (SEM), which included testing the hypotheses of the study.

3.7.1. Normality

The normality of the distribution revealed that the observed univariate skewness values were -0.59 (minimum) and 0.30 (maximum), and the univariate kurtosis values were -1.08 (minimum) and 1.00 (maximum). A critically important assumption when employing SEM analyses in general, and when using AMOS.v²⁴ in particular, is that the data have a multivariate normal distribution [60]. It is very important to check multivariate normality before data analysis is undertaken [60]. When using SEM analyses, in particular, the data must be multivariate kurtotic, a condition for a multivariate distribution of the observed variables. However, the absence of abnormal values in the assessment of univariate skewness and kurtosis does not mean that there is no abnormal distribution in the multivariate skewness and kurtosis; the opposite is not necessarily true [60]. Therefore, an assessment of multivariate skewness and kurtosis was conducted in this research for all the variables, and the results show that there were no values that were equal to or greater than 1. This means the data for this study were normally distributed. Table 2 shows the multivariate skewness and kurtosis results.

Table 2. Multivariate skewness and kurtosis.

Variables	N	Mean	Std. Deviation	Skewness		Kurtosis	
				Statistic	Std. Error	Statistic	Std. Error
Ethical Issues	364	2.97	0.54	−0.12	0.13	0.16	0.26
Disclosure Quality	364	3.14	0.45	0.30	0.13	1.00	0.26
Internal Control	364	3.62	0.58	−0.59	0.13	−0.08	0.26
Ownership Structure	364	3.26	0.67	−0.08	0.13	−0.40	0.26
Relevance	364	3.87	0.61	−0.12	0.13	−0.01	0.26
Faithful Representation	364	3.81	0.65	−0.06	0.13	−0.09	0.26
Understandability	364	4.05	0.54	0.06	0.13	0.01	0.26
Comparability	364	3.90	0.61	−0.36	0.13	0.73	0.26
Financial Reporting Quality	364	3.87	0.49	−0.015	0.128	0.55	0.26
Corporate Social Responsibility	364	3.88	0.84	−0.10	0.13	−1.08	0.26
Valid N (listwise)	364						

3.7.2. Demographic Profile of Respondents

Table 3 shows the demographic profiles of the respondents, 61.0% of whom were males ($n = 222$), while the remaining 39.0% ($n = 142$) were females. These percentages were considered to be logical in the Iraqi context. In terms of age, 14.8% ($n = 54$) of the respondents were between the ages of 18 and 25 years, 16.2% ($n = 59$) were between the ages of 26 and 30 years, 37.9% ($n = 138$) were between the ages of 31 and 35 years, 24.2% ($n = 88$) were between the ages of 36 and 40 years, and 6.9% ($n = 25$) were above the age of 40 years. In addition, concerning the working experience of the respondents, 14.6% ($n = 53$) of them had been working in banks for 0–5 years, 37.6% ($n = 137$) for 6–10 years, 34.6% ($n = 126$) for 11–15 years, 8.2% ($n = 30$) for 16–20 years, and 4.9% ($n = 18$) for more than 20 years. Regarding the educational qualifications of the respondents, 18.4% ($n = 67$) of them were diploma holders, 64.3% ($n = 234$) were bachelor degree holders, 11.3% ($n = 41$) were holders of a master's degree, and 3.8% ($n = 14$) were PhD holders, while 2.2% ($n = 8$) of them were holders of other qualifications. Table 3 provides a summary of the findings on the demographic profiles of the respondents in the present research.

Table 3. Demographic profile of the respondents.

Profile	Category	Frequency	Percent %	Cumulative Percent
Gender	Male	222	61.0	61.0
	Female	142	39.0	100.0
Age	18–25 years	54	14.8	14.8
	26–30 years	59	16.2	31.0
	31–35 years	138	37.9	69.0
	36–40 years	88	24.2	93.1
	Above 40 years	25	6.9	100.0
Experience	0–5 years	53	14.6	14.6
	6–10 years	137	37.6	52.2
	11–15 years	126	34.6	86.8
	16–20 years	30	8.2	95.1
	More than 20	18	4.9	100.0
Education	Diploma	67	18.4	18.4
	Bachelor	234	64.3	82.7
	Master	41	11.3	94.0
	PhD	14	3.8	97.8
	Other	8	2.2	100.0

3.7.3. Assessment of Measurement Model

A measurement model shows how latent variables have been measured through their observed variables and assesses their measurement properties. In addition, before proceeding to the structural equation modeling (SEM), the measurement model properties need to be satisfied. Furthermore, in the present study, six reflective variables were used, namely, ethical issues, disclosure quality, internal control, ownership structure, corporate social responsibility, and financial reporting quality. These variables were measured through forty-five items. CFA for all reflective variables was performed in AMOS.v24. The assessment of the measurement model is usually conducted for reliability and validity. Through CFA, the reliability and validity of all scales can be examined. Therefore, the model fit indices revealed that there was an adequate fit between the model and the data, whereas the outcomes showed that the CMIN statistic was 1802.115, $DF = 926$, and $CMIN = (CMIN/DF = 1802.115/926 = 1.946)$. The p -value associated with this result was $p < 0.000$, $CFI = 0.961$, $TLI = 0.958$, and $RMSEA = 0.051$. These indices achieved an acceptable fit according to [1–3]. The model shown in Figure 2 displays the variables with circles, while the items shown with rectangles were used to measure these variables.

Convergent validity is a type of variable validity. It is the extent to which scale items are presumed to represent a variable based on a range of facts on the same variable. Although the result of Cronbach's alpha (α) for all the variables was between 0.95 and 0.96, these values were greater than the value of 0.70. The result of the composite reliability (CR) for all the variables was between 0.83 and 0.97, although these values were greater than the value of 0.70. The result of the average variance extracted (AVE) for all the variables was between 0.55 and 0.89, although these values were greater than the value of 0.50. The result of the maximum shared variance (MSV) for all the variables was between 0.07 and 0.15, although these values were less than the value of AVE. Additionally, the result of the maximal reliability (MaxR-H) for all the variables was between 0.83 and 0.97, although these values were greater than the value of 0.80. Therefore, based on these results, the present research acquired the recommended levels of convergent validity. Moreover, the results presented acceptable indicators of reliability and convergent validity, as shown in Table 4.

3.7.4. Assessment of Structural Equation Modeling

Structural equation modeling (SEM) is very useful in examining inter-dependent relationships among latent variables [61]. It is designed to assess how good a proposed conceptual model can fit the data collected and also to ascertain the structural relationships

between the sets of latent variables [60]. The direction of the relationship between the variables showed there was a direct relationship between the independent variables and dependent variables. In this study, the measurement and structural models were generated and estimated using SPSS.v²⁵ and AMOS.v²⁴. The goodness of fit of the structural equation model indicated an acceptable fit, where, specifically, the CMIN statistic was 1544.939, DF = 726, and CMIN = (CMIN /DF = 1544.939/726 = 2.128). The *p*-value associated with this result was *p* < 0.000, CFI = 0.959, TLI = 0.956, and RMSEA = 0.056. These indices achieved an acceptable fit. Figure 3 shows the SEM that included all the study variables.

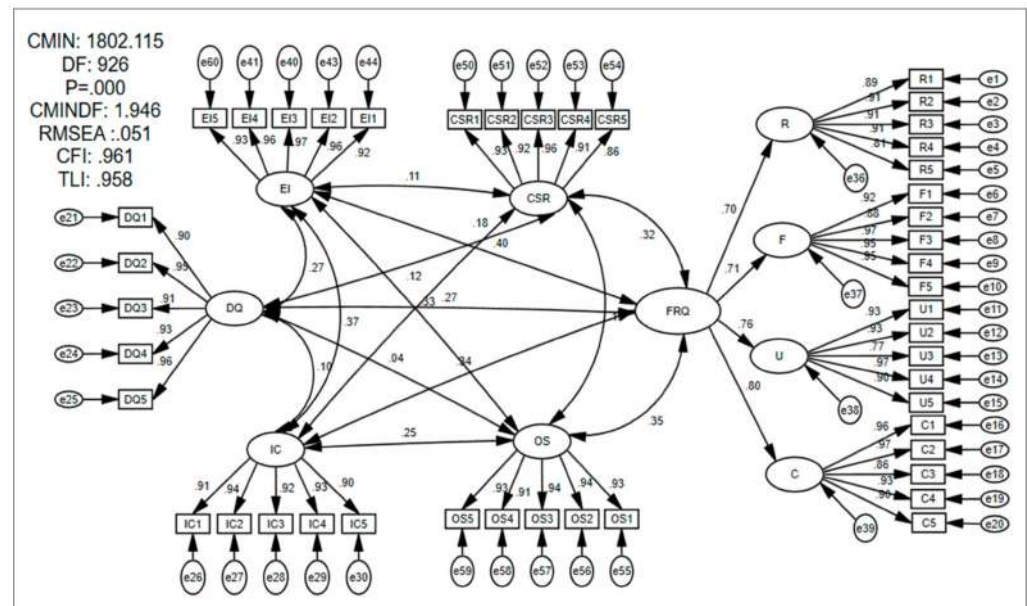

Figure 2. Assessment of measurement model. Note: CMIN = chi-square fit statistic; TLI = Tucker–Lewis index; CFI = comparative fit index; RMSEA = root mean square error of approximation; DF = degrees of freedom.

Table 4. Convergent validity for the overall measurement model.

Variables	α	CR	AVE	MSV	MaxR(H)
EI	0.954	0.978	0.899	0.158	0.981
DQ	0.964	0.970	0.866	0.076	0.973
IC	0.955	0.965	0.847	0.137	0.966
OS	0.969	0.970	0.867	0.125	0.971
CSR	0.960	0.963	0.838	0.105	0.969
FRQ	0.959	0.834	0.557	0.158	0.839

This section shows the direct relationships between the determinants of creative accounting and financial reporting quality. The results of H1a show a positive and significant relationship between ethical issues and financial reporting quality ($\beta = 0.200$; $t = 3.328$; $p < 0.000$). Therefore, the relationship between ethical issues and financial reporting quality was supported. The result for H1b indicates a positive and significant relationship between disclosure quality and financial reporting quality ($\beta = 0.185$; $t = 3.427$; $p < 0.000$). Therefore, the relationship between disclosure quality and financial reporting quality performance was supported. Furthermore, the result for H1c indicates a positive and significant relationship between internal control and financial reporting quality ($\beta = 0.207$; $t = 3.640$; $p < 0.000$). Therefore, the relationship between internal control and financial reporting quality was supported. Finally, the results of H1d show a positive and significant relationship between ownership structure and financial reporting quality ($\beta = 0.219$; $t = 3.912$; $p < 0.000$). Therefore, the relationship between ownership structure and financial reporting quality was supported, as shown in Table 5.

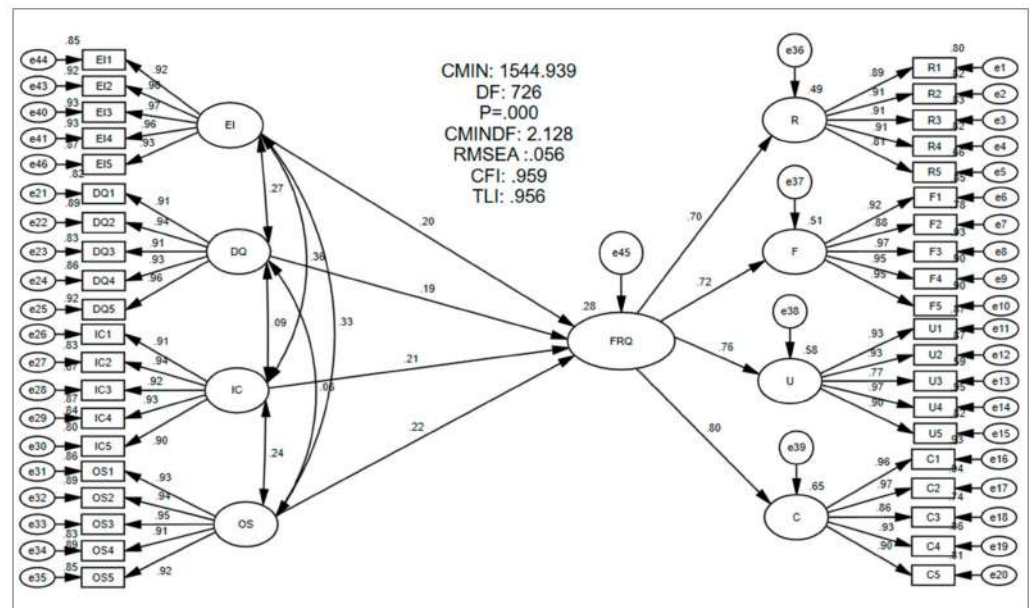

Figure 3. Assessment of structural equation modeling. Note: CMIN = chi-square fit statistic; TLI = Tucker–Lewis index; CFI = comparative fit index; RMSEA = root mean square error of approximation; DF = degrees of freedom.

Table 5. Relationship between creative accounting determinants and financial reporting quality.

No	Relationship	Beta	t-Value	p-Value	Decision
H1a	EI → FRQ	0.200	3.328	***	Supported
H1b	DQ → FRQ	0.185	3.427	***	Supported
H1c	IC → FRQ	0.207	3.640	***	Supported
H1d	OS → FRQ	0.219	3.912	***	Supported

Note: *** = $p < 0.000$.

Finally, SEM was applied to detect and estimate the strength of the moderating effect of corporate social responsibility on the relationship between the determinants of creative accounting (ethical issues, disclosure quality, internal control, ownership structure) and financial reporting quality. The goodness of fit of the moderating factor corporate social responsibility indicated an acceptable fit, where, specifically, the CMIN statistic was 74.650, DF = 26, and CMIN = (CMIN /DF = 74.650/26 = 2.871). The p -value associated with this result was $p < 0.000$, CFI = 0.902, and RMSEA = 0.072, while the R square was 0.454. These indices achieved an acceptable fit. Figure 4 shows that corporate social responsibility had an effective impact on the relationship between creative accounting and financial reporting quality within an interactive practice.

In addition, this section shows the indirect moderating effect of corporate social responsibility on the four determinants of creative accounting and financial reporting quality. The result for H2a indicates that corporate social responsibility had a positive and significant moderating effect on the relationship between ethical issues and financial reporting quality ($\beta = 0.249$; $t = 5.973$; $p < 0.000$). Therefore, the moderating effect of corporate social responsibility on the relationship between ethical issues and financial reporting quality was supported. The result for H2b indicates that corporate social responsibility had a negative and insignificant moderating effect on the relationship between disclosure quality and financial reporting quality ($\beta = 0.060$; $t = 1.537$; $p < 0.124$). Therefore, the moderating effect of corporate social responsibility on the relationship between disclosure quality and financial reporting quality was unsupported. The result for H2c shows that corporate social responsibility had a positive and significant moderating effect on the relationship between internal control and financial reporting quality ($\beta = 0.211$; $t = 4.826$; $p < 0.000$). Therefore,

the moderating effect of corporate social responsibility on the relationship between internal control and financial reporting quality was supported. The results for H2d show that corporate social responsibility had a positive and significant moderating effect on the relationship between ownership structure and financial reporting quality ($\beta = 0.241$; $t = 5.630$; $p < 0.000$). Therefore, the moderating effect of corporate social responsibility on the relationship between ownership structure and financial reporting quality was supported. Table 5 enumerates the results of the moderating effect of corporate social responsibility on the relationship between creative accounting and financial reporting quality. Table 6 display the moderating effect of corporate social responsibility on creative accounting determinants and financial reporting quality.

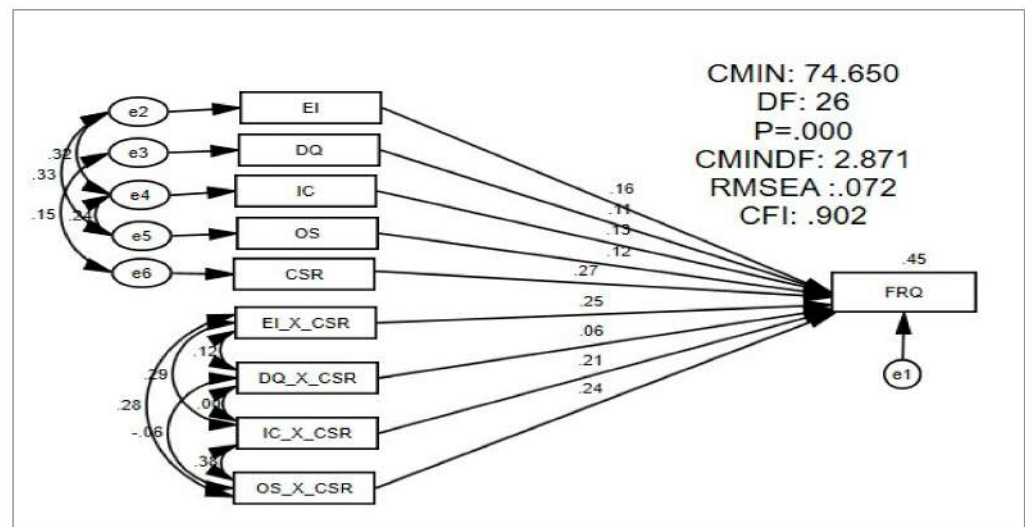

Figure 4. Statistical model of the moderating factor of corporate social responsibility.

Corporate social responsibility effectively impacted the relationship between creative accounting and financial reporting quality within an interactive practice. Meanwhile, corporate social responsibility strengthened the positive relationship between ethical issues and financial reporting quality. As shown in (a), the slope of high ethical issues has a steeper gradient as compared to low ethical issues. This shows that the positive relationship between ethical issues and financial reporting quality is stronger when corporate social responsibility is high in comparison to lower corporate social responsibility. Moreover, corporate social responsibility strengthened the positive relationship between disclosure quality and financial reporting quality. As shown in (b), the slope of high disclosure quality has a steeper gradient as compared to low disclosure quality. This shows that the positive relationship between disclosure quality and financial reporting quality is stronger when corporate social responsibility is high in comparison to lower corporate social responsibility.

Additionally, corporate social responsibility strengthened the positive relationship between internal control and financial reporting quality. As shown in (c), the slope of high internal control has a steeper gradient as compared to low internal control. This shows that the positive relationship between internal control and financial reporting quality is stronger when corporate social responsibility is high in comparison to lower corporate social responsibility. Finally, corporate social responsibility had a negative and insignificant effect on the relationship between ownership structure and financial reporting quality. As shown in (d), the slope of high ownership structure has a steeper gradient as compared to low ownership structure. This shows that the relationship between ownership structure and financial reporting quality is stronger when corporate social responsibility is low in comparison to higher corporate social responsibility. All of the above-mentioned indications are shown in Figure 5.

Table 6. Moderating effect of corporate social responsibility on creative accounting determinants and financial reporting quality.

No	Relationship	Beta	t-Value	p-Value	Decision	
H2a	EI → FRQ	0.158	3.717	***	Supported	Supported
	CSR → FRQ	0.266	6.812	***	Supported	
	CSR_X_EI → FRQ	0.249	5.973	***	Supported	
H2b	DQ → FRQ	0.113	2.880	0.004	Supported	Unsupported
	CSR → FRQ	0.266	6.812	***	Supported	
	CSR_X_DQ → FRQ	0.060	1.537	0.124	Unsupported	
H2c	IC → FRQ	0.125	3.016	0.003	Supported	Supported
	CSR → FRQ	0.266	6.812	***	Supported	
	CSR_X_IC → FRQ	0.211	4.926	***	Supported	
H2d	OS → FRQ	0.119	2.822	0.005	Supported	Supported
	CSR → FRQ	0.266	6.812	***	Supported	
	CSR_X_OS → FRQ	0.241	5.630	***	Supported	

Note: *** = $p < 0.000$.

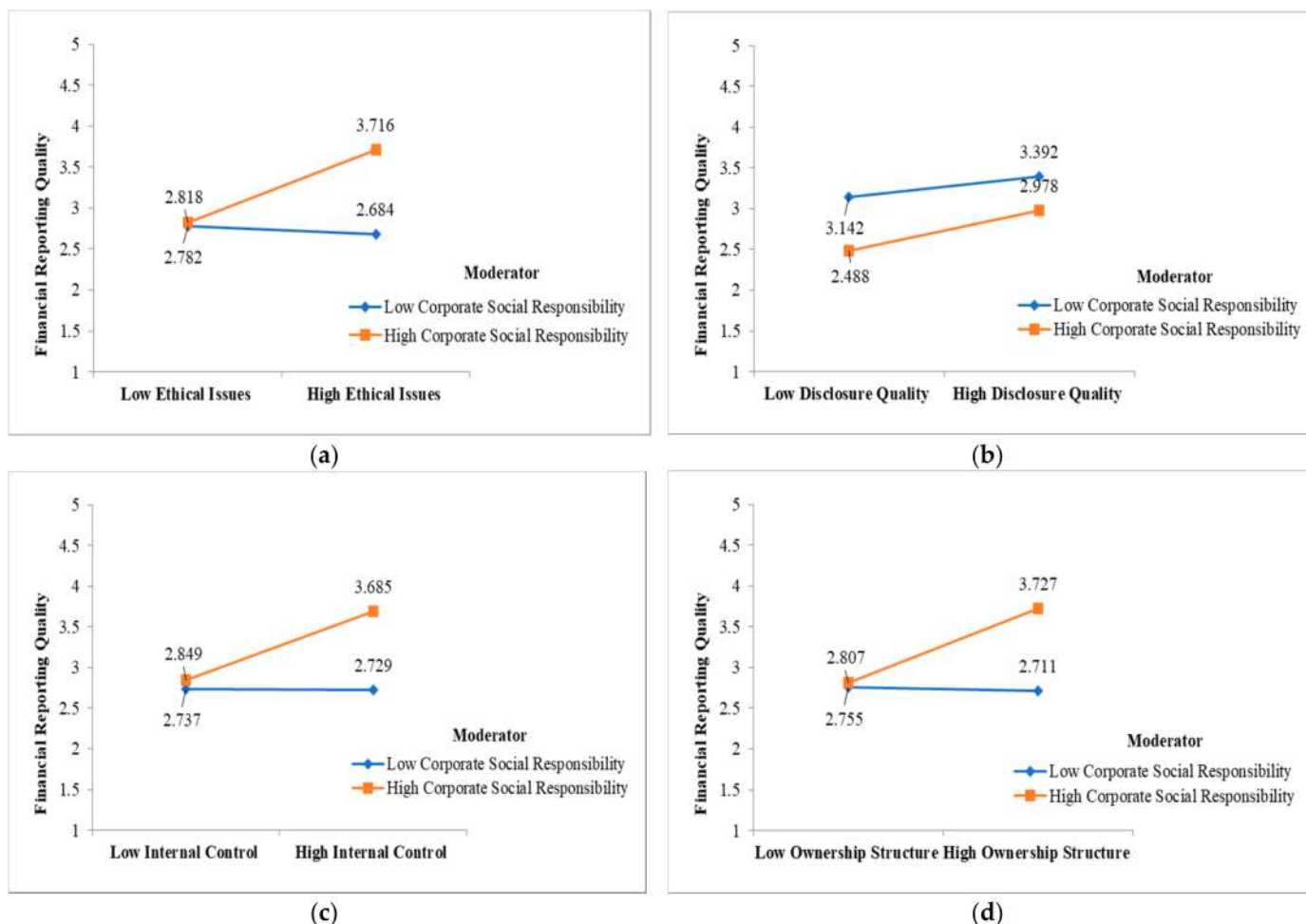

Figure 5. This figure contains four graphs which are as follows: (a) two-way interaction of CSR on EI and FRQ; (b) two-way interaction of CSR on DQ and FRQ; (c) two-way interaction of CSR on IC and FRQ; (d) two-way interaction of CSR on OS and FRQ.

4. Discussion

This part of the study discusses the findings related to the first research question on the direct relationship between the determinants of creative accounting and financial reporting

quality. In this respect, the present research findings explain the positive implications of the determinants on identifying creative accounting practices as proposed in the hypotheses within the context of Iraqi commercial banks. Accordingly, the result for hypothesis H1a was ($t = 3.328$), which aligns with the assumptions provided by agency theory, where the hypothesis indicated significant impacts of maintaining ethical issues on the quality of financial reporting. Furthermore, the results reaffirm that ethical aspects lead to the establishment of a higher quality of financial reporting practices, as shown in the context of Iraqi commercial banks. Moreover, the results acknowledge the findings in previous studies presented by [10,47,55,62], which demonstrate limited consideration of ethical issues on creative accounting practices in the context of commercial banks.

In addition, the result of H1b ($t = 3.427$) indicates a significant relationship between the constructs with limited operation of disclosure procedures in the context of commercial banks. This determination designated the higher implications of creative accounting practices to the quality of financial reporting in the banking sector, which was found to be consistent with the previous literature [9,44,63]. The implementation of new institutional theory contributed to explaining the underlying preposition that limited disclosure practice in the commercial bank context was due to the pressure exerted by the institutional setup related to ownership structure. These results are in good agreement with numerous studies in the literature which display the significance of the linkage between these determinants and accounting practice [19,36,64]. However, the present research findings are contradicted by other studies that proposed a limited controlling role of disclosure quality in creative accounting practice [28,65,66]. In brief, disclosure quality has been found to be one of the essential determinants of institutional transparency that increase the trust of the public in the financial reporting quality of banks. This finding is supported with high consistency in previous claims cited in [67] on maintaining ethical concerns through disclosure quality.

The results of the last two hypotheses related to the first research question are H1c ($t = 3.640$) and H1d ($t = 3.912$). As mentioned earlier, the present research findings show a significant inter-correlated relationship between the determinants of creative accounting, i.e., each of the determinants has an effect on the others. The origin of this relationship is clearly identified in the previous literature, and it is verified in the present research findings. Thus, limited consideration of ethical issues and disclosure quality results in limited implementation of internal control. These procedures enable the practice of creative accounting to take place in the commercial banking sector at various levels according to the ownership structure of the bank. Thus, the present findings are consistent with previous studies that indicated poor internal control may lead to higher errors and inaccurate financial disclosure of the financial reporting quality of banks [46,68,69].

Therefore, the ownership structure theory sufficiently explains the findings concerning the last two hypotheses through identifying the manipulation practices adopted in the banks to avoid a poor performance of the share value and loss of control in the business. Therefore, the relationship between ownership structure and financial reporting quality can be reflected as fewer agency problems and information asymmetry in family organizations, in contrast to non-familial organizations [49,70]. These descriptions verify previous results in the literature which proposed high impacts of ownership structure on providing a faithful representation in the reports presented by commercial banks [71,72]. Yet, again, the present findings are found to be consistent with those in [34,73], which asserted that complying with a high level of internal control can reduce the risk of mitigation policies to increase reporting quality through the determinants of creative accounting.

It is worth declaring that the outcomes of this research support the current literature concerning the correlation between the determinants of creative accounting to detect fraudulent practices, but these determinants fail to control these practices at safe levels [22,74,75]. These findings apply to the context of Iraqi commercial banks, although dedicated efforts are constantly made to retain and establish healthy relations with outside shareholders as one of the major resources; however, additional enhancement is required to reduce fraudulent practices within creative accounting to present a high quality of financial reports.

This, in turn, implies that the internal banking system would sustain ethical issues, disclose honest information to the public, and implement qualified internal control for faithful representations of the financial reporting practice in Iraqi commercial banks.

The present study findings reveal a statistically significant impact of employees' opinion on CSR on the relation between employees' opinion on creative accounting determinants and employees' opinion on financial reporting quality. Thus, the results provide a feasible answer for the second research question and help to examine the proposed hypotheses. The significance of corporate social responsibility for the commercial banks' financial reporting quality indeed validated most of the proposed hypotheses, wherein H2a ($t = 5.892$), H2c ($t = 4.936$), and H2d ($t = 5.626$). These values are found to agree with those of previous studies of [21,76], who considered banks as entities that operate in society and are obliged to ensure fair and consistent benefits to all stakeholders and safeguarding to uphold social justice responsibility. Moreover, the findings are consistent with a previous study presented by [77], who reported that corporate social responsibility plays a prominent role in attaining sustainable financial practice, especially for the commercial banking sector.

Moreover, the obtained results and analysis suggest that decision makers are affected by motives and business values; relatively, the choice of actions in the business influences corporate social responsibility activities. The moderating mechanism of CSR is presented sufficiently within the perspective of neo-institutional theory, which displays a significant interaction between CSR and the maintenance of ethical issues. However, some researchers such as [9,12] indicated that corporate social responsibility contributes to concealing questionable activities and creative accounting, but the adoption of highly independent internal control contributes to overcoming this complication. These indications contribute to clearing up the inconsistency of previous studies [9,19] on the mechanism of CSR in controlling creative accounting practices. In addition, the findings show a positive relationship between the variables of the study and CSR that impacts the power of non-executive members in the banks to design and develop business strategic plans for sustainable competitive development. These findings are found to be in good agreement with previous findings addressed in the studies of [58,78].

In addition, the findings show that the independence of audit committees is linked to a higher level of financial reporting, which is consistent with both the techniques used in CSR, and the integrated correlation between the determinants of creative accounting. Thus, the present research findings support previous findings in [21] that the effect of CSR on auditing financial practices in various ownership structures is a standardized representation of financial reports of the financial status of banks. On this basis, the fourth hypothesis (H2d) was supported. Moreover, the results on the positive relationship between disclosure quality and internal control can also be related to the norms of interaction between the agency and neo-institutional theories, which state that autonomous independent audits, who have the freedom to make decisions and carry out error detection, can easily facilitate effective work and provide an unbiased judgment.

Contrary to the expectations, this study did not find a significant relationship in hypothesis H2b ($t = 1.536$), which indicated the absence of any statistical significance between corporate social responsibility and the determinant of disclosure quality. These findings further support the idea of [9,79] that CSR does not significantly impact the level of disclosure in the business to maintain a faithful presentation and understandability of the financial reporting. Thus, the current findings confirm the conventional foundations of CSR that can contribute to identifying customer needs, tracking new market trends, analyzing competitors' actions, observing technological developments, and involving customers or suppliers in the product development process, thus playing a decisive role in preparing accurate financial reports. In brief, the results of H2b validate the suggestions made by [9,43,66] concerning the limited impacts of CSR on disclosure quality, which found a dominant controlling role of business managers in preparing financial reports for stakeholders and the public.

In addition, this combination of findings for H2b provides some support for [9] and the conceptual premise of neo-institutional theory that banks disclose information due to the pressure exerted by the institutional setup. Moreover, agency theory suggests that banks emphasize comprehensive aspects of accountability concerning numerous stakeholders. Thus, CSR does not add significant value to the willingness of banks to disclose any financial information. These findings corroborate the findings of [80], who suggested that the scope of CSR is restricted to achieving significant disclosure of the business, especially in financial reporting. Therefore, the directors of commercial banks must determine the suitability of their actions for the public, bringing stability, harmony, and strength to society.

5. Conclusions

The present study was set up to reconceptualize and reform the current situation in the financial sector, especially in banks of developing nations. The present study focused on commercial banks, which are considered as the backbone of the national economy of any nation. Thus, it was vital to investigate this sector for identifying its strengths and weaknesses, which the present study highlighted regarding creative accounting and financial reporting practices. Previous studies showed the capability to hide some fraudulent practices within creative accounting, which directly impacts the quality of financial reporting [12,55,81]. However, the literature review showed that the determinants of creative accounting could contribute to identifying any fraudulent practices which resulted in a high quality of financial reporting [82–84]. However, it has been reported in previous studies that the financial banking sector performs many creative accounting practices which result in a low quality of financial reporting [46,56,85].

Therefore, a theoretical investigation was conducted through a systematic literature review of previous relevant studies. The intensive review of the literature contributed to identifying the essential determinants of creative accounting, elements of financial reporting, and active aspects of corporate governance in the research context, which impact reporting practice in the commercial banking sector. Moreover, the review contributed to designing the present research questions and hypotheses on the relevant phenomena of interest, while the practical application of the present study framework resolved various shortcomings identified in previous studies through the moderating role of some corporate governance aspects. As a result, the framework contributed to attaining the present research objectives. Subsequently, this study makes several contributions to assessing and enhancing reporting practice in the financial sector, which is especially authenticated to be a valid model in the commercial banking sector.

As discussed in the previous sections, the relationship between the determinants of creative accounting and financial reporting encountered some noticeable limitations. Thus, it is necessary to measure the implications of these determinants on financial reporting practice using a survey questionnaire which reviews the intentions and conceptualization of the main persons contributing to preparing financial policies in commercial banks. Relatively, the increasing attention towards creative accounting and higher academic demands on financial reporting in practice motivated this research aimed at addressing the main determinants in relation to the criteria of financial reporting. Taken together, the present research findings show that the degree of impact of creative accounting determinants is linked to the aspect of corporate governance. This, in turn, was found to directly impact the quality of financial reporting practice in commercial banks, whereas the balanced use of these aspects can maintain diagnostic and interactive knowledge.

Most of the earlier reports concluded that creative accounting determination generally depends on the framework, idiosyncrasy, and interconnectivity [20,46,86]. It was indicated that a perfect solution is impossible for all the financial sectors wherein creative accounting might be inappropriate and dependent on the contexts. Therefore, the level of creative practice may vary appreciably from one sector to another [87]. This fact inspired the present study to adopt a triangulated application of agency, neo-institutional, and ownership theories to explain the correlation between the variables of the study and the moderator,

as shown in the designed conceptual framework. The results contribute to presenting concurrent evidence on the flexibility of creative accounting determinants with a higher degree of implication on corporate aspects and financial reporting quality. Additionally, the obtained findings strongly emphasize the significant impacts of the moderator in enhancing the determination of creative practice, as well as the strength of the quality of financial reporting within Iraqi commercial banks.

Furthermore, the results acquired from the present investigation extend our knowledge through offering valid answers for the research questions. These findings show the importance of corporate aspects of corporate social responsibility that moderate the relationships among the determinants and financial reporting quality in commercial banks of Iraq. Thus, entrepreneurial administration connected to the identification of new scopes and recognition of problems as well as trends in commercial banks is needed. This process enables the management to contribute to the adjustment and upgrading of daily schedules; largely, this is a tactical act for transforming the reporting practice of banks into a higher level of qualified reporting practice [12,88]. This identification is shown in the findings of this study, which support the required reform through the moderation of corporate aspects of financial reporting quality. In conclusion, the results of this study show harmony with the views demonstrated in most of the previous studies in the literature on the determination of creative practice that influences the preparation of financial reports through the moderation of corporate social responsibility of the banking sector in Iraq, such as [89,90].

The limitation of this research is that the focus on a single research context (Iraqi commercial banks) may mean the results are not generalizable to every financial sector, each with different issues. Thus, potential context limitations are acknowledged, particularly the distinctions amongst developing and developed countries affecting the views of creative accounting allocations and financial reporting for identifying the quality of business performance. It is important to note that various banking sectors in different contexts, imposing more limitations, are worth studying in the future. Additionally, nationalized differences in the culture can appreciably influence the perception of the research regarding some important issues of creative accounting practice and its impacts on the quality of financial reporting, thus offering more conclusive evidence.

Thus, the present research limitations open up new directions for further studies. Moreover, this study used a single source of data via a survey questionnaire from the Iraqi research context. Future studies could contribute to collecting data from multiple sources such as financial reports, surveys, and interviews that may facilitate making several modifications and estimates of the implications of business governance on creative accounting practices and the quality of financial reports. In addition, it is recommended that future longitudinal studies include the opinions of multiple sources of information from management, and other auditing levels, in order to confirm their impacts on developing the determination of creative accounting practices and the quality of financial reports. Briefly, this study focused on four determinants of creative accounting (ethical issues, disclosure quality, internal control, and ownership structure) and one aspect of corporate governance (corporate social responsibility). Future studies should determine the mechanism of other determinants and corporate aspects in enhancing the quality of financial reporting. All of these future developments may offer pioneering findings which could contribute to validating the present research findings and those of previous studies in the literature.

Author Contributions: Conceptualization, I.A.A. and N.H.; methodology, I.A.A. and N.H.; formal analysis, I.A.A., N.H., H.H., N.M.A.-R. and M.A.A.; investigation, I.A.A., M.A.A. and N.H.; resources, I.A.A. and N.H.; writing—original draft preparation, I.A.A.; writing—review and editing, I.A.A., M.A.A., and N.H. All authors have read and agreed to the published version of the manuscript.

Funding: This research received no funding.

Acknowledgments: The authors are grateful to the Middle East University, Amman, and Zarqa University, Zarqa, Jordan, for the financial support granted to cover the publication fee of this article. The authors also are grateful to the editor and the anonymous reviewers for providing very

constructive and useful comments that enabled us to make additional efforts to improve the clarity and quality of our research.

Conflicts of Interest: The authors declare no conflict of interest, as the authors are the funders of this research.

Appendix A

Table A1. Measurement items.

Corporate Social Responsibility
– Our bank supports employees' education.
– Flexible policies enable employees to better coordinate work and personal life.
– Our bank gives adequate contributions to charities.
– A program in place to reduce the amount of energy and materials wasted in our bank.
– We encourage partnerships with local businesses and banks.
Creative Accounting Determinants
Ethical Issues
– The ethical Issues prevalent in our Bank do not affect the presentation of the financial reporting.
– Financial reports should be prepared and presented in accordance with the ethical guidelines of our bank.
– Ethical standards are duly observed in the presentation of the financial reporting procedures in our bank.
– The accountants in our bank are always objective in the presentation of the financial reports.
– The bank has revealed a code of conduct/ethics.
Disclosure Quality
– There are significant effects for the reports' disclosure on the quality of the financial reporting practice in our bank.
– Disclosure practice is affected by the professional competence of the professional accountant.
– The quality of disclosure practice for financial reporting is criticized with financial reporting standards.
– Disclosure of internal control reports increases the auditory role.
– The disclosure of financial reporting is affected by the professional accountant practice.
Internal Control
– The availability of continuous control reports in the bank can enhance the internal control functions which lead to improving the quality of financial reporting.
– The existence of recommendations and advice about potential improvement in the reports leads to improve the quality of financial reporting.

Table A1. *Cont.*

– The existence of matching and reasonableness reports for different periods in the reports lead to improve the quality of financial reporting.
– Segregation of duties leads to improve the quality of financial reporting.
– A clear determination for the responsibilities and authorities among departments leads to improve the quality of financial reporting.
Ownership Structure
– Our bank provides equal access to information for shareholders and investment analysts.
– Ownership in our bank would be stronger since managers have more incentives to opportunistically exploiting quality financial reporting.
– The concentrated ownership in our bank can overcome the free-rider problem and enhance the quality of financial reporting by improving the monitoring of management.
– In our bank’s high ownership structure, controlling shareholders are less dependent on minority shareholders and may take benefits from them.
– Ownership structure reflects the banks’ selection to disclose high-quality information as a corporate governance practice to monitor managerial activities.
Financial Reporting Quality Dimensions
Relevance
– The annual report discloses forward-looking information about the bank.
– The bank uses fair values instead of historical.
– Cost in preparing financial statements.
– The presence of looking statements helps the development of expectations and predictions by the users regarding the bank’s future.
– The presence of non-financial information in terms of business opportunities and risks complements the financial information.
Faithful Representation
– The annual report highlights the positive and negative events in a balanced way when discussing the annual results.
– Accounting principles are firmly followed in our bank.
– The annual report extensively discloses information on corporate governance issues.
– The annual report contains disclosure on environmental issues.
– The annual report explains the choice of accounting.
Understandability
– The degree to which the annual report is well-organized.
– The notes to the financial statements are clear.

Table A1. Cont.

–	The use of language and technical jargon is easy to follow in the annual report.
–	The annual report included a comprehensive glossary.
–	The use of graphs and tables in the financial reports enhances the quality of financial reporting.
Comparability	
–	The notes to revisions in accounting estimates and judgments explain the implications of the revision.
–	The results of the current accounting period are compared with the results of previous accounting periods.
–	Information in the annual report is comparable to information provided by other organizations.
–	The annual report presents financial index numbers and ratios.
–	The industry comparison enhances the quality of financial reporting.

References

- Al-Shaer, H. Sustainability reporting quality and post-audit financial reporting quality: Empirical evidence from the UK. *Bus. Strategy Environ.* **2020**, *29*, 2355–2373. [\[CrossRef\]](#)
- Farhan Jedi, F.; Nayan, S. International Journal of Economics and Financial Issues The Effect of Oil Price Volatility, Board of Directors Characteristics on Firm Performance of Iraq Listed Companies: A Conceptual Framework. *Int. J. Econ. Financ. Issues* **2018**, *8*, 342–350.
- Suprianto, E.; Suwarno, S.; Murtini, H.; Rahmawati, R.; Sawitri, D. Audit Committee Accounting Expert and Earnings Management with “Status” Audit Committee as Moderating Variable. *Indones. J. Sustain. Account. Manag.* **2017**, *1*, 49–58. [\[CrossRef\]](#)
- Aluchna, M.; Roszkowska-Menkes, M. *Conceptual Framework, Regulation and Practice BT—Corporate Social Responsibility in Poland: Strategies, Opportunities and Challenges*; Non-financial Reporting; Długopolska-Mikonowicz, A., Przytuła, S., Stehr, C., Eds.; Springer International Publishing: Cham, Switzerland, 2019; pp. 213–236. ISBN 978-3-030-00440-8.
- Chang, W.F.; Amran, A.; Iranmanesh, M.; Foroughi, B. Drivers of sustainability reporting quality: Financial institution perspective. *Int. J. Ethics Syst.* **2019**, *35*, 632–650. [\[CrossRef\]](#)
- Campello, M.; Giambona, E.; Graham, J.R.; Harvey, C.R. Liquidity management and corporate investment during a financial crisis. *Rev. Financ. Stud.* **2011**, *24*, 1944–1979. [\[CrossRef\]](#)
- Vladu, A.B.; Amat, O.; Cuzdriorean, D.D. Truthfulness in Accounting: How to Discriminate Accounting Manipulators from Non-manipulators. *J. Bus. Ethics* **2017**, *140*, 633–648. [\[CrossRef\]](#)
- Abed, I.A.; Hussin, N.; Ali, M.A.; Nikkeh, N.S.; Mohammed, A. Creative Accounting Phenomenon in the Financial Reporting: A Systematic Review Classification, Challenges. *Technol. Rep. Kansai Univ.* **2020**, *62*, 1–10.
- Martin, R.; Yadiati, W.; Pratama, A.; Rubio-Misas, M.; Alshbili, I.; Elamer, A.A.; Beddewela, E.; Harun, M.S.; Hussainey, K.; Mohd Kharuddin, K.A.; et al. Doing Good with Creative Accounting? Linking Corporate Social Responsibility to Earnings Management in Market Economy, Country and Business Sector Contexts. *Sustainability* **2019**, *8*, 4568. [\[CrossRef\]](#)
- Tassadaq, F.; Malik, Q.A. Creative accounting and financial reporting: Model development and empirical testing. *Int. J. Econ. Financ. Issues* **2015**, *5*, 544–551.
- Mudel, S. Creative Accounting and Corporate Governance: -A Literature Review. *SSRN Electron. J.* **2015**. [\[CrossRef\]](#)
- Brauweiler, H.-C.; Yerimpasheva, A.; Bagalbayeva, Z.; Lari Dashtbayaz, M.; Salehi, M.; Safdel, T.; Agyei-Mensah, B.K.; Salin, A.S.A.P.; Ismail, Z.; Smith, M.; et al. Avoiding creative accounting: Corporate governance and leadership skills. *Zesz. Teor. Rachun.* **2019**, *12*, 9–19. [\[CrossRef\]](#)
- Trisanti, T. Did the corporate governance reform have effect on creative accounting practices in emerging economies? The case of Indonesian listed companies. *J. Glob. Bus. Adv.* **2016**, *9*, 52. [\[CrossRef\]](#)
- Makhael, N.K.B.; Sherer, M.L.J. The effect of political-economic reform on the quality of financial reporting in Egypt. *J. Financ. Report. Account.* **2018**, *16*, 245–270. [\[CrossRef\]](#)

15. Atabay, E.; Dinç, E. Financial Information Manipulation and Its Effects on Investor Demands: The Case of BIST Bank. In *Contemporary Issues in Audit Management and Forensic Accounting*; Grima, S., Boztepe, E., Baldacchino, P.J., Eds.; Contemporary Studies in Economic and Financial Analysis; Emerald Publishing Limited: Bingley, UK, 2020; Volume 102, pp. 41–56. [\[CrossRef\]](#)
16. Akpanuko, E.E.; Umoren, N.J. The influence of creative accounting on the credibility of accounting reports. *J. Financ. Report. Account.* **2018**, *16*, 292–310. [\[CrossRef\]](#)
17. Abed, I.A.; Hussin, N.; Ali, M.A.; Othman, R.; Mohammed, M.A. A Systematic Critical Review of Creative Accounting and Financial Reporting. *Technol. Rep. Kansai Univ.* **2020**, *62*, 5113–5130.
18. Johl, S.K.; Kaur Johl, S.; Subramaniam, N.; Cooper, B. Internal audit function, board quality and financial reporting quality: Evidence from Malaysia. *Manag. Audit. J.* **2013**, *28*, 780–814. [\[CrossRef\]](#)
19. Qian, W.; Hörisch, J.; Schaltegger, S.; Baalouch, F.; Ayadi, S.D.; Hussainey, K.; Agyei-Mensah, B.K.; Nagata, K.; Nguyen, P.; Daske, H.; et al. A study of the determinants of environmental disclosure quality: Evidence from French listed companies. *J. Clean. Prod.* **2015**, *22*, 1608–1619. [\[CrossRef\]](#)
20. Rozidi, M.; Nor, N.A.M.; Aziz, N.A.; Rosli, N.A.; Mohaiyadin, N.M.H. Relationship between Auditors' Ethical Judgments, Quality of Financial Reporting and Auditors' Attitude towards Creative Accounting: Malaysia Empirical Evidence. *Int. J. Bus. Humanit. Technol.* **2015**, *5*, 81–87.
21. Sharma, V.D.; Sharma, D.S.; Ananthanarayanan, U. Client importance and earnings management: The moderating role of audit committees. *Audit. A J. Pract. Theory* **2011**, *30*, 125–156. [\[CrossRef\]](#)
22. Cernusca, L.; David, D.; Nicolaescu, C.; Gomoi, B.C. Empirical Study on the Creative Accounting Phenomenon. *Stud. Univ. Vasile Goldis Arad-Econ. Ser.* **2016**, *26*, 63–87. [\[CrossRef\]](#)
23. Alia, M.A.; Hussin, N.; Abed, I.A. E-Banking Fraud Detection: A Short Review. *Int. J. Innov. Creat. Change* **2019**, *6*, 67–87.
24. Charles, E.E.; Mary, C.A. Influence of Professional Ethics and Standards in Less Developed Countries: An Assessment of Professional Accountants in Nigeria. *Asian J. Econ. Bus. Account.* **2018**, *6*, 2–6.
25. Cletus, A.; Oghoghomeh, T. Ethics of Accounting Profession in Nigeria. *J. Bus. Econ.* **2014**, *5*, 1374–1382.
26. Yao, S.; Wang, Z.; Sun, M.; Liao, J.; Cheng, F. Top executives' early-life experience and financial disclosure quality: Impact from the Great Chinese Famine. *Account. Financ.* **2020**, *60*, 4757–4793. [\[CrossRef\]](#)
27. Plumlee, M.; Brown, D.; Hayes, R.M.; Marshall, R.S. Voluntary environmental disclosure quality and firm value: Further evidence. *J. Account. Public Policy* **2015**, *34*, 336–361. [\[CrossRef\]](#)
28. Gerwanski, J.; Kordsachia, O.; Velte, P. Determinants of materiality disclosure quality in integrated reporting: Empirical evidence from an international setting. *Bus. Strategy Environ.* **2019**, *28*, 750–770. [\[CrossRef\]](#)
29. Paolone, F.; Magazzino, C. Earnings manipulation among the main industrial sectors. evidence from Italy. *Evid. Italy* **2014**, 253–261.
30. Krishnan, J.; Krishnan, J.; Liang, S. Internal control and financial reporting quality of small firms: A comparative analysis of regulatory regimes. *Rev. Account. Financ.* **2020**, *19*, 221–246. [\[CrossRef\]](#)
31. Foster, B.P.; McClain, G.; Shastri, T. The auditor's report on internal control & fraud detection responsibility: A comparison of French and U.S. users' perceptions. *J. Account. Ethics Public Policy* **2013**, *14*, 221–257.
32. Abed, I.A.; Hussin, N.; Ali, M.A. Piloting the Role of Corporate Governance and Creative Accounting in Financial Reporting Quality. *Technol. Rep. Kansai Univ.* **2020**, *62*, 2–7.
33. Bardhan, I.; Lin, S.; Wu, S.L. The quality of internal control over financial reporting in family firms. *Account. Horizons* **2015**, *29*, 41–60. [\[CrossRef\]](#)
34. Bimo, I.D.; Siregar, S.V.; Hermawan, A.A.; Wardhani, R. Internal control over financial reporting, organizational complexity, and financial reporting quality. *Int. J. Econ. Manag.* **2019**, *13*, 331–342.
35. Nagata, K.; Nguyen, P. Ownership structure and disclosure quality: Evidence from management forecasts revisions in Japan. *J. Account. Public Policy* **2017**, *36*, 451–467. [\[CrossRef\]](#)
36. Udin, S.; Khan, M.A.; Javid, A.Y. The effects of ownership structure on likelihood of financial distress: An empirical evidence. *Corp. Gov. Int. J. Bus. Soc.* **2017**, *17*, 589–612. [\[CrossRef\]](#)
37. Abdallah, A.A.-N.; Ismail, A.K. Corporate governance practices, ownership structure, and corporate performance in the GCC countries. *J. Int. Financ. Mark. Inst. Money* **2017**, *46*, 98–115. [\[CrossRef\]](#)
38. Alzoubi, E.S.S. Ownership structure and earnings management: Evidence from Portugal. *Australas. Account. Bus. Financ. J.* **2016**, *24*, 135–161. [\[CrossRef\]](#)
39. Miran, A.; Oudah, H.; Abed, R. Factors Affecting Creative Accounting Practices and Means Used to Limit their Effect on the Credibility of Financial Statements. *Int. J. Innov. Creat. Change* **2020**, *13*, 1082–1100.
40. Duh, M.; Djokić, D. Transparency and Disclosure Regulations—A Valuable Component of Improving Corporate Governance Practice in Transition Economies. In *Social Responsibility and Corporate Governance*; Springer: Berlin/Heidelberg, Germany, 2020; pp. 193–228.
41. Liu, H.; Lee, H.-A. The effect of corporate social responsibility on earnings management and tax avoidance in Chinese listed companies. *Int. J. Account. Inf. Manag.* **2019**, *27*, 632–652. [\[CrossRef\]](#)
42. Martínez-Ferrero, J.; Banerjee, S.; García-Sánchez, I.M. Corporate social responsibility as a strategic shield against costs of earnings management practices. *J. Bus. Ethics* **2016**, *133*, 305–324. [\[CrossRef\]](#)

43. Alipour, M.; Ghanbari, M.; Jamshidinavid, B.; Taherabadi, A. The relationship between environmental disclosure quality and earnings quality: A panel study of an emerging market. *J. Asia Bus. Stud.* **2019**, *13*, 326–347. [[CrossRef](#)]
44. Qian, W.; Hörisch, J.; Schaltegger, S.; Baalouch, F.; Ayadi, S.D.; Hussainey, K.; Agyei-Mensah, B.K.; Nagata, K.; Nguyen, P.; Daske, H.; et al. Assessing Disclosure Quality: A Methodological Issue. *J. Mod. Account. Audit.* **2015**, *11*, 466–475. [[CrossRef](#)]
45. Tang, Q.; Chen, H.; Lin, Z. How to measure country-level financial reporting quality? *J. Financ. Report. Account.* **2016**, *14*, 230–265. [[CrossRef](#)]
46. Lim, S.J.; White, G.; Lee, A.; Yuningsih, Y. A longitudinal study of voluntary disclosure quality in the annual reports of innovative firms. *Account. Res. J.* **2017**, *30*, 89–106. [[CrossRef](#)]
47. Gras, E.; Palacios Manzano, M.; Hernández Fernández, J. Investigating the relationship between corporate social responsibility and earnings management: Evidence from Spain. *BRQ Bus. Res. Q.* **2016**, *19*, 289–299. [[CrossRef](#)]
48. Oh, W.Y.; Chang, Y.K.; Martynov, A.; Hicheon, K.; Heechun, K.; Peggy, M.L. Ownership structure and the relationship between financial slack and R&D investments: Evidence from Korean Firms. *Organ. Sci.* **2011**, *19*, 283–297. [[CrossRef](#)]
49. Han, S.; Amrah, M.R.; Obaid, M.M.; Qawqzeh, H.K.; Endut, W.A.; Rashid, N.; Mustafa, M. Ownership Structure and Financial Reporting Quality: Influence of Audit Quality Evidence from Jordan. *SSRN Electron. J.* **2019**, *8*, 2212–2220. [[CrossRef](#)]
50. Arthur, N.; Chen, H.; Tang, Q. Corporate ownership concentration and financial reporting quality: International evidence. *J. Financ. Report. Account.* **2019**, *17*, 104–132. [[CrossRef](#)]
51. Yasser, Q.R.; Al Mamun, A.; Hook, M. The impact of ownership structure on financial reporting quality in the east. *Int. J. Organ. Anal.* **2017**, *25*, 178–197. [[CrossRef](#)]
52. Krejcie, R.V.; Morgan, D.W. Determining sample size for research activities. *Educ. Psychol. Meas.* **1970**, *30*, 607–610. [[CrossRef](#)]
53. Pearlson, K.E.; Saunders, C.S.; Galletta, D.F. *Managing and Using Information Systems: A Strategic Approach*; John Wiley & Sons: Hoboken, NJ, USA, 2019; ISBN 111956056X.
54. Sekaran, U.; Bougie, R. *Research Methods for Business: A Skill Building Approach*; John Wiley & Sons: Hoboken, NJ, USA, 2016; ISBN 1119165555.
55. De Jesus, T.A.; Pinheiro, P.; Kaizeler, C.; Sarmiento, M. Creative Accounting or Fraud? Ethical Perceptions Among Accountants. *Int. Rev. Manag. Bus. Res.* **2020**, *9*, 58–78. [[CrossRef](#)]
56. Aifuwa, H.O.; Embele, K.; Musa, S. Ethical Accounting Practices and Financial Reporting Quality. *EPRA Int. J. Multidiscip. Res.* **2018**, *4*, 31–44.
57. Salameh, R.S. What is the Impact of Internal Control System on the Quality of Banks' financial Statements in Jordan? *Acad. Account. Financ. Stud. J.* **2019**, *23*, 1–10.
58. Rupp, D.E.; Shao, R.; Skarlicki, D.P.; Paddock, E.L.; Kim, T.Y.; Nadisic, T. Corporate social responsibility and employee engagement: The moderating role of CSR-specific relative autonomy and individualism. *J. Organ. Behav.* **2018**, *39*, 559–579. [[CrossRef](#)]
59. Rashid, M.M. Financial reporting quality and share price movement-evidence from listed companies in Bangladesh. *J. Financ. Report. Account.* **2020**, *18*, 425–458. [[CrossRef](#)]
60. Byrne, B.M. Structural equation modeling with AMOS: Basic concepts, applications, and programming (multivariate applications series). *N. Y. Taylor Fr. Group* **2016**, *396*, 7384.
61. Hair, J.F.; Black, W.C.; Babin, B.J.; Anderson, R.E. *Multivariate Data Analysis. Always Learning*; Pearson: London, UK, 2013.
62. Shafer, W.E.; Poon, M.C.C.; Tjosvold, D. Ethical climate, goal interdependence, and commitment among Asian auditors. *Manag. Audit. J.* **2013**, *28*, 217–244. [[CrossRef](#)]
63. Tri Wahyuni, E.; Puspitasari, G.; Puspitasari, E. Has IFRS improved Accounting Quality in Indonesia? A Systematic Literature Review of 2010–2016. *J. Account. Invest.* **2020**, *21*, 19–44. [[CrossRef](#)]
64. Mudel, S. A Study to Show the Relation between Creative Accounting and Corporate Governance. *SSRN Electron. J.* **2016**. [[CrossRef](#)]
65. Cooray, T.; Gunarathne, A.D.N.; Senaratne, S. Does corporate governance affect the quality of integrated reporting? *Sustainability* **2020**, *12*, 4262. [[CrossRef](#)]
66. Yasser, Q.R.; Al Mamun, A.; Ahmed, I. Quality of financial reporting in the Asia-Pacific region: The influence of ownership composition. *Rev. Int. Bus. Strategy* **2016**, *26*, 543–560. [[CrossRef](#)]
67. Zaman, R.; Bahadar. Role of media and independent directors in corporate transparency and disclosure: Evidence from an emerging economy. *Corp. Gov. Int. J. Bus. Soc.* **2018**, *16*, 593–608. [[CrossRef](#)]
68. Muraina, S.A.; Dandago, K.I. Effects of implementation of International Public Sector Accounting Standards on Nigeria's financial reporting quality. *Int. J. Public Sect. Manag.* **2020**, *33*, 323–338. [[CrossRef](#)]
69. Raimo, N.; Vitolla, F.; Marrone, A.; Rubino, M. The role of ownership structure in integrated reporting policies. *Bus. Strateg. Environ.* **2020**, *29*, 2238–2250. [[CrossRef](#)]
70. Singla, C.; George, R.; Veliyath, R. Ownership structure and internationalization of Indian firms. *J. Bus. Res.* **2017**, *81*, 130–143. [[CrossRef](#)]
71. Aguilera, R.V.; Crespi-Cladera, R. Global corporate governance: On the relevance of firms' ownership structure. *J. World Bus.* **2016**, *51*, 50–57. [[CrossRef](#)]
72. Khlif, H.; Ahmed, K.; Souissi, M. Ownership structure and voluntary disclosure: A synthesis of empirical studies. *Aust. J. Manag.* **2017**, *42*, 376–403. [[CrossRef](#)]

73. Lari Dashtbayaz, M.; Salehi, M.; Safdel, T. The effect of internal controls on financial reporting quality in Iranian family firms. *J. Fam. Bus. Manag.* **2019**, *9*, 254–270. [CrossRef]
74. Al-Hashemi, H.T. The effect of creative accounting practices on measuring and presenting accounting information in the financial statements—A comparative analytical study on a sample of the financial and industrial sectors listed on the Iraq Stock Exchange. *J. Ma'aen* **2020**, *10*, S1.
75. Ibrahim, H.A.M.; Abdul Hussain, M.; Abdullah, Q.M. The Impact of Creative Accounting Methods on the Quality of Accounting Information: A Field Study on the Financial Reports of Companies Listed in the Iraq Stock Exchange. *J. Manag. Sci.* **2017**, *9*.
76. Ndebugri, H.; Tweneboah Senzu, E. Analyzing the Critical Effect of Creative Accounting Practice in the Corporate Sector of Ghana. 2017. Available online: https://papers.ssrn.com/sol3/papers.cfm?abstract_id=3236965 (accessed on 10 January 2022).
77. Popescu, C.R.G. Sustainability assessment: Does the oecd/g20 inclusive framework for beps (base erosion and profit shifting project) put an end to disputes over the recognition and measurement of intellectual capital? *Sustainability* **2020**, *12*, 10004. [CrossRef]
78. García-Sánchez, I.; Hussain, N.; Martínez-Ferrero, J.; Ruiz-Barbadillo, E. Impact of disclosure and assurance quality of corporate sustainability reports on access to finance. *Corp. Soc. Responsib. Environ. Manag.* **2019**, *26*, 832–848. [CrossRef]
79. Mahboub, R. Main determinants of financial reporting quality in the Lebanese banking sector. *Eur. Res. Stud. J.* **2017**, *20*, 706–726. [CrossRef]
80. Nobanee, H.; Ellili, N. Does operational risk disclosure quality increase operating cash flows? *BAR-Brazilian Adm. Rev.* **2017**, *14*, 4. [CrossRef]
81. Roszkowska-Menkes, M.T. Integrating strategic CSR and open innovation. Towards a conceptual framework. *Soc. Responsib. J.* **2018**, *14*, 950–966. [CrossRef]
82. Mulford, C.W.; Comiskey, E.E. Creative Accounting and Accounting Scandals in the USA. 2012. Available online: <https://onlinelibrary.wiley.com/doi/abs/10.1002/9781119208907.ch19> (accessed on 10 January 2022).
83. Muhannad; Hussein, M. Creative accounting practices and their reflection on the reliability of the data published in the financial statements An applied study on a sample of commercial banks in Iraq. *AL-Dananeer Mag.* **2017**, *1*.
84. Tunji, S.T.; BENJAMIN, R.D.; Bintu, A.M.; Flomo, L.J. Creative accounting and investment decision in listed manufacturing firms in Nigeria. *J. Account. Tax.* **2020**, *12*, 39–47.
85. Gupta, C.M.; Kumar, D. Creative accounting a tool for financial crime: A review of the techniques and its effects. *J. Financ. Crime* **2020**, *27*, 397–411. [CrossRef]
86. Goel, S. The quality of reported numbers by the management: A case testing of earnings management of corporate India. *J. Financ. Crime* **2014**, *21*, 355–376. [CrossRef]
87. Salehi, M.; Shirazi, M.; Al-Shaer, H.; Salama, A.; Toms, S.; Sahyoun, N.; Magnan, M.; Bala, H.; Amran, N.A.; Shaari, H.; et al. Audit committee and integrated reporting practice: Does internal assurance matter? *Manag. Audit. J.* **2020**, *35*, 1639–1662. [CrossRef]
88. Alzeban, A. Influence of internal audit reporting line and implementing internal audit recommendations on financial reporting quality. *Meditari Account. Res.* **2020**, *28*, 26–50. [CrossRef]
89. Al-Olimat, D.N.H.; Al-Olimat, N.H.; Al Shbail, M.O.; Lect, A.; Al, F.H.; Abdulla, F.; Shakir, I.; Abdameer, W.; Miri, A.; Hanna, S.N.; et al. The Impact of Cognitive Creativity in Accounting among Jordanian Internal Auditors on Detecting Creative Accounting Practices, A Field Study. *Int. J. Bus. Soc. Sci.* **2020**, *10*, 149. [CrossRef]
90. Jadah, H.M. Board Characteristics and Bank Performance: Evidence from Iraq. *J. Indep. Stud. Res. Soc. Sci. Econ.* **2016**, *14*, 29–41. [CrossRef]