

The effects of board characteristics and firm size on firm value and financial performance

Slamet Riyadi^{a*}, Donny Arif^b, Abdul Halik^a and Kurnia Dwi Ariestya^b

^aUniversitas 17 Agustus 1945 Surabaya, Indonesia

^bUniversitas Maarif Hasyim Latif, Indonesia

CHRONICLE

Article history:

Received June 18, 2021

Received in revised format June 28 2021

Accepted July 7 2021

Available online

June 25 2023

Keywords:

Board Characteristic

Firm Size

Firm Value

Financial Performance

ABSTRACT

This research was conducted to see the influence of board characteristics, the firm size on firm value, and financial performance on companies with completed mergers and acquisitions on the Indonesian stock exchange. This study was used to look at financial performance, specifically in 7 years after the company made a merger from 2013-2020. This research instrument uses quantitative analysis data by testing predetermined hypotheses. The study also found that not all variables significantly impact the company's firm value and financial performance when conducting mergers. The main finding is that the more excellent board characteristic of the merger company will result in no improvement in the company's financial performance; this is due to a large number of improper decision-making actions because the rules issued by the board hinders it.

© 2023 Growing Science Ltd. All rights reserved.

1. Introduction

In the era of free trade and technological advancement, every company is required to improve the performance of all sectors. During the past decade, there has been an increase in the company's merger activity to enhance the company's performance. Therefore, a measuring instrument is needed that can be used to assess the company's performance with a focus on financial performance after mergers and acquisitions. In this study, one of the measuring instruments of economic performance is to measure the role of board characteristics in determining the company's policies and objectives. The same research was conducted by Datta et al. (2020) on how board characteristic roles can affect the company's performance, which shows that governance structures related to board characteristics impact the creation of higher value shareholders. The board of directors is significant in the company's management and has the power to control the company's resources. In the same context, the board of directors acts as an effective surveillance system to protect stakeholders' interests (Pucheta-Martínez & Gallego-Álvarez, 2019). The board of directors is the highest form of internal corporate governance with their responsibilities as a supervisory body and can provide the company's long-term strategy (Al-Mamun & Seamer, 2021). In the literature, it is known that the focus of the board of directors is for the development of organizational strategies governing the allocation of resources of companies by bringing knowledge, expertise, and access to resources to the board (Mishra & Kapil, 2018). The board of commissioners, board of directors, and shareholders are included in the committee that creates good corporate governance if it can make the right decisions for its development in the future. Every company wants to improve its financial performance so that the value of the company will also increase. To measure the value of the company required standard measurement of the factor firm size of all aspects. Smaller company sizes are considered to lack adequate resources in influencing financial performance (Lin et al., 2019), so a decision is needed for the merger to get a complete improvement in the company's performance. Dimensions used to assess the company's focus on small and medium-sized

* Corresponding author.

E-mail address: slametriyadi10@untag-sby.ac.id (S. Riyadi)

companies (Teirlinck, 2017). In theory, mergers are a step to increase the company's equity and assets, and this research is done to prove whether a merger will constantly improve financial performance. However, Brown et al. (2018) explain that mergers can simultaneously reduce board connections and busyness to have the opposite effect on the company's performance. The lack of study focuses on financial performance for an extended period after the merger. With the merger, it is expected that there will be an increase in productivity that can also ultimately improve the company's financial performance.

2. Problem Formulation

With the results of the background description supported by some of the above theories, can be formulated several problem formulations:

1. Does the influence of board characteristics affect firm value on companies listed on the Indonesia Stock Exchange?
2. Does there be a substantial effect on the firm value on companies listed on the Indonesia Stock Exchange?
3. Does there be an indirect influence of board characteristics on financial performance on companies listed on the Indonesia Stock Exchange?
4. Does there be an indirect influence of firm size on financial performance on companies listed on the Indonesia Stock Exchange?
5. Does the firm value affect the financial performance of companies listed on the Indonesia Stock Exchange?

3. Literature Review

As stated in the previous theory, board size is a crucial board characteristic to obtain optimal corporate governance (García-Ramos & Díaz, 2020). With optimal control, it is expected that the company's value will also increase and encourage the company's financial performance to be better (Huang et al., 2020). Financial performance is a reality in an economy with complexity and cannot be explained by one factor but by connecting it to several variables (Cuadrado-Ballesteros et al., 2017). Another case from (Fan et al., 2019) suggests that board characteristics with social ties between CEOs and Directors can negatively influence the market, as it can reduce monitoring and incur agency costs resulting in a decrease in the company's value.

H₁: *There is an influence between board characteristics to firm value.*

Eisenberg et al. (1998) suggested that there is no consistent relationship between firm size and firm value. There is a small board size of less than six in the company, but this can be reflected through the company's profitability. From this research, it is explained that a large firm size can improve the company's performance in general and may also improve its financial performance. Alqahtani et al. (2020) also confirm that large, medium, and small companies do not affect aggregate stock indices. This means that it has not guaranteed that firm size can be used as a reference that the company has a good firm value or not. Research (Ji et al., 2020) also suggests that deviant acts of power measured using stochastic models can lower the value of companies and even bankruptcies.

H₂: *There is an influence between firm size and firm value.*

According to Bond (2009), the giant board does not prove that its financial performance is getting better, although it is affected by its liquidity and inventory. This study is supported by Ghosh and Ansari (2018) which found that the size of boards needs to be re-examined since it does not match the improvement in their company's performance and tends to be negative. Some theories show that not all companies with larger boards show positive performance. Still, this study focuses on how board characteristics can have a better financial performance impact after the company merges with other companies.

H₃: *There is an influence between board characteristics on financial performance.*

The study of firm size using green innovation yang was conducted by Tomomi (2010) by applying environmental strategies can provide increased business activity opportunities and can provide a competitive advantage. The study explained that firm size is represented by ecological processes that contextually impact the company's financial performance. Some of this literature shows that most of the company's size has a significant impact on the company's financial performance, with the addition of several factors, of course, that support. However, many problems occur, so it needs to be reviewed by choosing characteristics to measure the influence of firm size on its financial performance.

H₄: *There is an influence between firm size on financial performance.*

Financial performance is assumed to reduce noise and provide managers with information asymmetrically, leading to a long-term positive impact (Gan et al., 2020). This indicates that firm value positively impacts when managers are structurally able to take policy appropriately. Previous research conducted showed that companies in the U.S. influence international diversification positively impact firm value. While in another study, international diversification is closely

related to the company's performance. This interconnectedness illustrates a clear flow that substantial value can also affect the company's financial performance.

H₅: *There is an influence between the firm value on financial performance.*

The literature above can be described as a conceptual framework that shows this research process in the future.

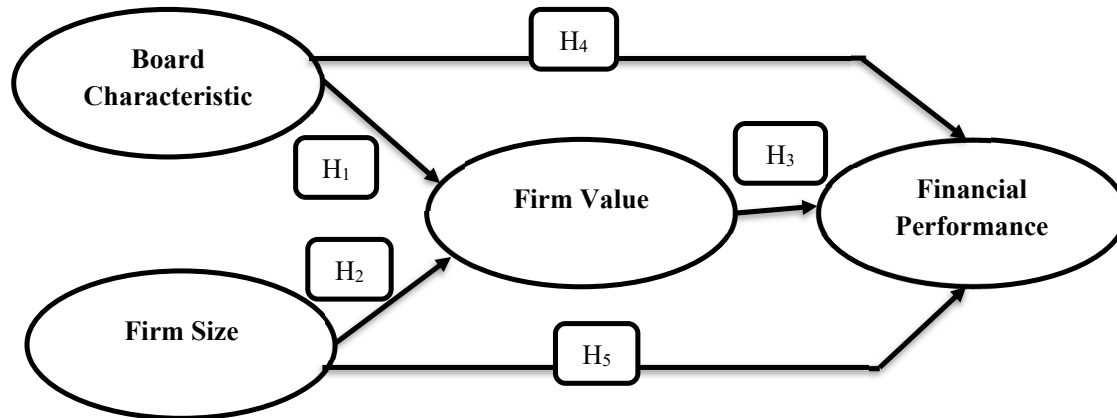

Fig. 1. Concept Framework

4. Method

This study uses companies' data listed on the Indonesia stock exchange in 2001-2013 (merger and acquisition activities). With merger data until 2013 is expected to get data on the company's financial statements up to 2014-2020. Sampling techniques are performed using "Purposive Sampling". Research utilizing this technique tends to look for theoretically important cases (Van Ryzin, 1995). Merger activities up to 2013 based on data capital market library Indonesia as many as 32 exercises and 30 of them conducted companies registered in IDX. An analysis data technique uses the PLS Analysis tool by predicting the influence of variable X on variable Y and explaining the relationship theoretically. A partial least square can create limitations on the ability to predict relationships between variables of interest and distinguish domain data variants from sources and targets when building latent variants (G. Huang et al., 2020).

5. Result

Description variable board characteristic, this variable generates the following table serving:

Table 1
Variable Board Characteristic

Indicator	n	Minimum	Maximum	Mean	Std Deviation
Board of Commissioners	210	3	12	5.53	1.65
Board Independence	210	1	5	2.81	1.25
Board of Directors	210	4	11	5.62	1.72
Audit Committee	210	1	4	2.92	0.89

Table 1 shows that the average *Board of Commissioners* is six people, *Board Independence* is three people, *Board of Directors* is six people, and *Audit Committee* is three people.

Firm size in this study is measured by the total amount of assets owned by the company. The measurement of total assets is calculated using a rotation ratio to see the impact on the company's financial performance (Patin et al., 2020)

Table 2
Variable Firm Size

Indicator	n	Minimum	Maximum	Mean	Std Deviation
Total Assets	210	182.876	326.521.200	38.203.886	62.426.750

Table firm size shows that IDX companies conduct merger and acquisition activities, with an average total asset of Rp 38.204 trillion with the lowest total assets of Rp 182.86 billion. The most significant investments are Rp 326.521 Trillion. The standard deviation value shows a prominent figure of Rp 62.43trillion.

Table 3

Variable Firm Value

Indicator	n	Minimum	Maximum	Mean	Std Deviation
Closing Price (Rp)	210	60	18.230	2.426	4.122
PBV	210	0.0032	30.256	1.2565	4.233
Tobin's Q	210	0.1725	11.1023	1.0032	1.562

Table 3 of statistic results from variable firm value shows that the average shares produced from companies with mergers and acquisitions amounted to Rp 2,426, PBV ratio 1.2565, and Tobin's Q ratio was 1.0032.

Table 4

Variable Financial Performance

Indicator	n	Minimum	Maximum	Mean	Std Deviation
Liquidity Ratio (CR)	210	0.0089	12.0902	2.9952	3.2542
Assets Management Ratio (TATO)	210	0.0008	2.5868	0.5336	0.7256
Dept Management Ratio (DMR)	210	-5.4266	11.2256	3.0024	3.1233
ROA	210	-0.2231	0.5521	0.0663	0.1225
ROE	210	-1.2355	1.8865	0.3552	0.3556

Table 4 statistics from the variable financial performance show the average output value of C.R., TATO, DMR, ROA, and ROE during the seven years after the company conducted mergers and acquisitions.

Convergent Validity Phase 1 Testing

The calculation PLS algorithm shows outer loading value with convergent validity test on reflective indicator, and it is known that four hands have external loading value below 0.7. The results of calculating the PLS algorithm are seen in Table 5 below:

Table 5

Outer Loading Phase 1

Variable	Indicator	Outer Loading	Information
Board Characteristic	Board of Commissioners (X1.1)	0.617	Not Valid
	Board Independence (X1.2)	0.630	Not Valid
	Board of Directors (X1.3)	0.764	Valid
	Audit Committee (X1.4)	0.752	Valid
Firm Size	Total Asset (Ln) (X2.1)	1.000	Valid
Firm Value	Closing Price (Rp) (X3.1)	0.709	Valid
	PBV (X3.2)	0.814	Valid
	Tobin's Q (X3.3)	0.783	Valid
Financial Performance	Liquidity Ratio (CR) (X4.1)	0.730	Valid
	Assets Management Ratio (TATO) (X4.2)	0.738	Valid
	Dept Management Ratio (DMR) (X4.3)	0.641	Not Valid
	ROA (X4.4)	0.709	Valid
	ROE (X4.5)	0.655	Not Valid

Four indicators declared invalid will then be dropped for and then we reperformed the calculate PLS algorithm back at stage two. Outer loading test results can also be presented in the form of Fig. 2.

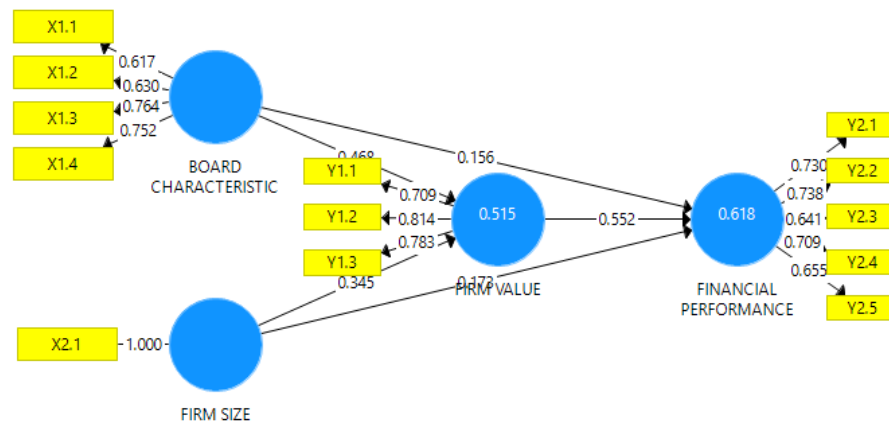
**Fig. 2.** PLS Model Estimation Results (Phase 1)

PLS model estimation results show that *the Board of Commissioners, Board Independence, Dept Management Ratio, and ROE* have outer loading values below 0.7, i.e., sequentially, the values are 0.617, 0.630, 0.641, and 0.655 the summed up is invalid. Furthermore, retesting will be conducted in stage 2.

Convergent Validity Phase 2 Testing

From test phase 1, it is known that four indicators are invalid, so no longer get a chance in this test.

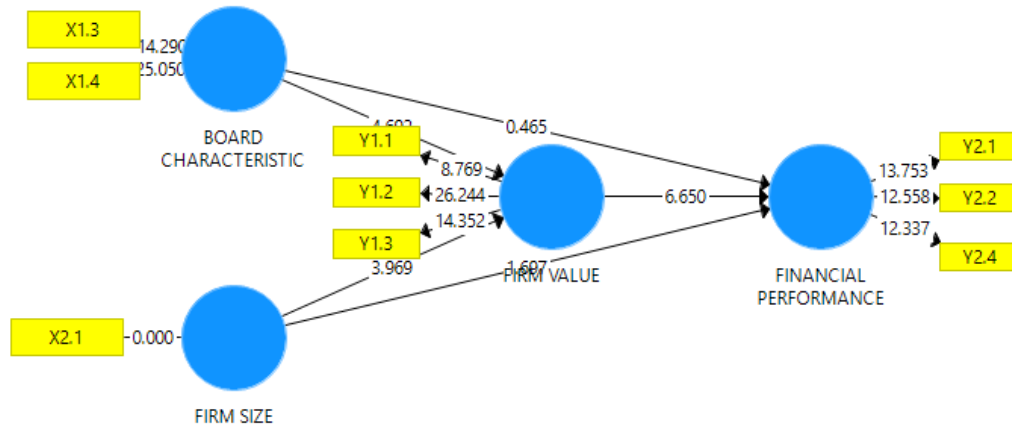

Fig. 3. PLS Model Estimation Results (Phase 2)

Fig. 3. PLS Model Estimation Results (Phase 2) show all construct indicators have friendly outer loading above 0.7 so that the promotion of stage 2 is declared to meet the validity of convergence.

Coefficient of Variable Influence Path (Path Coefficients)

Table 6
PLS Coefficient Value Of Influence Between Variables

Influence Between Variables	Path Coefficients	T- Stat	P-value
<i>Board Characteristic</i> → <i>Firm Value</i>	0.433	4.692	0.000
<i>Firm Size</i> → <i>Firm Value</i>	0.352	3.969	0.000
<i>Board Characteristic</i> → <i>Financial Performance</i>	0.053	0.465	0.642
<i>Firm Size</i> → <i>Financial Performance</i>	0.171	1.697	0.040
<i>Firm Value</i> → <i>Financial Performance</i>	0.603	6.650	0.000

1. Table 6 explained that the variable that significantly affects financial performance is firm value, which is indicated by the largest coefficient value of 0.603, consecutive firm size with coefficient values of 0.171, and board characteristic is 0.053.
2. From table 6 also explains that variable board characteristic has the most influence on firm value with coefficient value 0,433 and then varying firm size with a value of 0.352

Direct Effect Testing

This research's direct effect analysis can be seen in table 6. If the 2-tailed test finds the hypothesis acceptable if the T-Statistic value > 1.6521 or P-Value is lower than the value (α) 5%, the coefficient path above finds the hypothesis acceptable.

1. The statistic test resulted in a coefficient value of variable board characteristic against firm value is positive and significant with a value of 0.433 supported by p-value 0.000 (less than the value of $\alpha = 0.05$) and T-statistic 4.692 (Greater than 1.6521). This value indicates that the board characteristic positively affects the firm value, which means that the greater the attributes of the company's board will have a tangible impact on the solid matter. Based on the results of this test stated H_1 was received.
2. Statistic test results resulted in a coefficient value of variable firm size against firm value is positive and significant with a value of 0.352 supported by p-value 0.000 (less than the value of $\alpha = 0.05$) and T-statistic 3.969 (Greater than 1.6521). This value indicates that firm size has a positive effect on firm value, which means that the larger the fit size will have a tangible impact on firm value. Based on the results of this test stated H_2 was received.
3. Statistic test results resulted in a coefficient value of variable board characteristic to financial performance is positive and insignificant with a value of 0.053 supported by p-value 0.642 (more significant than the value of $\alpha = 0.05$) and T-statistic 0.465 (Less than 1.6521). This value indicates that board characteristics have a positive

effect on firm value, which means that the greater the attributes of the company's board do not have a tangible impact on financial performance. Based on the results of this test, it is stated H_3 was received.

4. Statistic test results in a coefficient value of variable firm size to financial performance is positive and significant with a value of 0.171 supported by p-value 0.040 (less than the value of $\alpha = 0.05$) and T-statistic 1.697 (Greater than 1.6521). This value indicates that firm size has a positive effect on financial performance, which means that the larger the fit size will have a tangible impact on financial performance. Based on the results of this test stated H_4 was received.
5. Statistic test results resulted in a coefficient value of variable firm value against financial performance is positive and significant with a value of 0.603 supported by p-value 0.000 (smaller than the value of $\alpha = 0.05$) and T-statistic 6.650 (Greater than 1.6521). This value indicates that firm value has a positive effect on financial performance, which means that the greater the substantial value will have a tangible impact on financial performance. Based on the results of this test stated H_5 was received.

6. Conclusion

The statistics variable board characteristic test results showed a positive influence on firm value; this is supported by research conducted by (Datta et al., 2020) that provides the same value to the board characteristic that affects the company's performance significantly. However, what is different in this study is the more extended period (7 years after mergers and acquisitions) in determining the board's success on the performance of companies that focus on assessing financial performance. The significant influence of variable board characteristics are board commissioners, board independence, board of directors, and audit committee can encourage firm value to increase along with the more significant assets owned and the right decision making. But the opposite is true in this study, that the larger the board will interfere with the company's financial performance after mergers and acquisitions. This is by research (Nugroho et al., 2021a) which shows that the company's financial performance is not influenced by the performance of the board or the existing board structure in a company. The positive value is also indicated by the firm size significantly affecting the substantial weight; this can be seen from the increase in the percentage value of the coefficient path to 35% during the period after the merger. Firm size also significantly affects financial performance, with a percentage of 17.1%. Thus it can be concluded that firm size affects indirect financial performance through firm value as variable moderator (Nugroho et al., 2021b). The support of variable moderators with a positive and significant deal with an immense weight of 60.3% variable firm value affects financial performance.

References

- Al-Mamun, A., & Seamer, M. (2021). Board of director attributes and CSR engagement in emerging economy firms: Evidence from across Asia. *Emerging Markets Review*, 46, 100749. <https://doi.org/https://doi.org/10.1016/j.ememar.2020.100749>
- Alqahtani, F., Hamdi, B., & Hammoudeh, S. (2020). The effects of global factors on the Saudi Arabia equity market by firm size: Implications for risk management based on quantile analysis and frequency domain causality. *Journal of Multinational Financial Management*, 100665. <https://doi.org/https://doi.org/10.1016/j.mulfin.2020.100665>
- Bond, J. K. (2009). Cooperative Financial Performance and Board of Director Characteristics: A Quantitative Investigation. *Journal of Cooperatives*, 22, 22–44. <http://purl.umn.edu/46430>
- Brown, A. B., Dai, J., & Zur, E. (2018). Too Busy or Well-Connected? Evidence from a Shock to Multiple Directorships. *The Accounting Review*, 94(2), 83–104. <https://doi.org/10.2308/accr-52165>
- Cuadrado-Ballesteros, B., Martínez-Ferrero, J., & García-Sánchez, I. M. (2017). Board Structure to Enhance Social Responsibility Development: A Qualitative Comparative Analysis of U.S. Companies. *Corporate Social Responsibility and Environmental Management*, 24(6), 524–542. <https://doi.org/https://doi.org/10.1002/csr.1425>
- Datta, D. K., Basuil, D. A., & Agarwal, A. (2020). Effects of board characteristics on post-acquisition performance: A study of cross-border acquisitions by firms in the manufacturing sector. *International Business Review*, 29(3), 101674. <https://doi.org/https://doi.org/10.1016/j.ibusrev.2020.101674>
- Eisenberg, T., Sundgren, S., & Wells, M. T. (1998). Larger board size and decreasing firm value in small firms. We wish to thank Asiakasti Oy for furnishing us with the data analyzed here, Clas Bergström, Jonathan Macey, David Yermack, and an anonymous referee for helpful comments, and Linda Bölling for . *Journal of Financial Economics*, 48(1), 35–54. [https://doi.org/https://doi.org/10.1016/S0304-405X\(98\)00003-8](https://doi.org/https://doi.org/10.1016/S0304-405X(98)00003-8)
- Fan, Y., Boateng, A., King, T., & MacRae, C. (2019). Board-CEO friendship ties and firm value: Evidence from U.S. firms. *International Review of Financial Analysis*, 65, 101373. <https://doi.org/https://doi.org/10.1016/j.irfa.2019.101373>
- Gan, H., Park, M. S., & Suh, S. (2020). Non-financial performance measures, CEO compensation, and firms' future value. *Journal of Business Research*, 110, 213–227. <https://doi.org/https://doi.org/10.1016/j.jbusres.2020.01.002>
- Gande, A., Schenzler, C., & Senbet, L. W. (2009). Valuation effects of global diversification. *Journal of International Business Studies*, 40(9), 1515–1532. <https://doi.org/10.1057/jibs.2009.59>
- García-Ramos, R., & Díaz, B. D. (2020). Board of directors structure and firm financial performance: A qualitative comparative analysis. *Long Range Planning*, 102017. <https://doi.org/https://doi.org/10.1016/j.lrp.2020.102017>
- Ghosh, S., & Ansari, J. (2018). Board characteristics and financial performance: Evidence from Indian cooperative banks.

- Journal of Co-Operative Organization and Management*, 6(2), 86–93. <https://doi.org/https://doi.org/10.1016/j.jcom.2018.06.005>
- Huang, G., Chen, X., Li, L., Chen, X., Yuan, L., & Shi, W. (2020). Domain adaptive partial least squares regression. *Chemometrics and Intelligent Laboratory Systems*, 201, 103986. <https://doi.org/https://doi.org/10.1016/j.chemolab.2020.103986>
- Huang, P., Lu, Y., & Wee, M. (2020). Corporate governance analysts and firm value: Australian evidence. *Pacific-Basin Finance Journal*, 63, 101430. <https://doi.org/https://doi.org/10.1016/j.pacfin.2020.101430>
- Ji, G., Dai, B., Park, S.-P., & Ahn, K. (2020). The origin of collective phenomena in firm sizes. *Chaos, Solitons & Fractals*, 136, 109818. <https://doi.org/https://doi.org/10.1016/j.chaos.2020.109818>
- Lin, W.-L., Cheah, J.-H., Azali, M., Ho, J. A., & Yip, N. (2019). Does firm size matter? Evidence on the impact of the green innovation strategy on corporate financial performance in the automotive sector. *Journal of Cleaner Production*, 229, 974–988. <https://doi.org/https://doi.org/10.1016/j.jclepro.2019.04.214>
- Mishra, R. K., & Kapil, S. (2018). Effect of board characteristics on firm value: evidence from India. *South Asian Journal of Business Studies*, 7(1), 41–72. <https://doi.org/10.1108/SAJBS-08-2016-0073>
- Nugroho, M., Arif, D., & Halik, A. (2021a). *The effect of financial distress on stock returns , through systematic risk and profitability as mediator variables*. 7, 1717–1724. <https://doi.org/10.5267/j.ac.2021.4.026>
- Nugroho, M., Arif, D., & Halik, A. (2021b). The effect of loan-loss provision, non-performing loans and third-party fund on capital adequacy ratio. *Accounting*, 7(10), 943–950. <https://doi.org/10.5267/j.ac.2021.1.013>
- Patin, J.-C., Rahman, M., & Mustafa, M. (2020). Impact of Total Asset Turnover Ratios on Equity Returns: Dynamic Panel Data Analyses. *Journal of Accounting, Business and Management (JABM); Vol 27 No 1 (2020): April* DO - 10.31966/Jabminternational.V27i1.559 . <http://journal.stie-mce.ac.id/index.php/jabminternational/article/view/559>
- Pucheta-Martínez, M. C., & Gallego-Álvarez, I. (2019). An international approach of the relationship between board attributes and the disclosure of corporate social responsibility issues. *Corporate Social Responsibility and Environmental Management*, 26(3), 612–627. <https://doi.org/https://doi.org/10.1002/csr.1707>
- Tashman, P., Marano, V., & Babin, J. (2019). Firm-specific assets and the internationalization–performance relationship in the U.S. movie studio industry. *International Business Review*, 28(4), 785–795. <https://doi.org/https://doi.org/10.1016/j.ibusrev.2019.03.003>
- Teirlinck, P. (2017). Configurations of strategic R&D decisions and financial performance in small-sized and medium-sized firms. *Journal of Business Research*, 74, 55–65. <https://doi.org/https://doi.org/10.1016/j.jbusres.2017.01.008>
- Tomomi, T. (2010). Environmental management strategy for small and medium-sized enterprises: Why do SMBs practice environmental management? *Asian Business & Management*, 9(2), 265–280. <https://doi.org/10.1057/abm.2010.6>
- Van Ryzin, G. G. (1995). Cluster analysis as a basis for purposive sampling of projects in case study evaluations. *Evaluation Practice*, 16(2), 109–119. [https://doi.org/https://doi.org/10.1016/0886-1633\(95\)90020-9](https://doi.org/https://doi.org/10.1016/0886-1633(95)90020-9)
- Yeung, A. C. L. (2008). Strategic supply management, quality initiatives, and organizational performance. *Journal of Operations Management*, 26(4), 490–502. <https://doi.org/https://doi.org/10.1016/j.jom.2007.06.004>



© 2023 by the authors; licensee Growing Science, Canada. This is an open access article distributed under the terms and conditions of the Creative Commons Attribution (CC-BY) license (<http://creativecommons.org/licenses/by/4.0/>).